

**Call Now for a Free  
Quote or Site Visit!**

222 S. Main St. 5th Floor  
Salt Lake City, UT 84101  
800-326-4403  
<https://www.mh-usa.com/>

Material Handling USA

SUPERSTORE

MH-USA

## Cylinder Carousel

The Cylinder Carousel is a semi/fully automated vertical carousel that can rotate up or down to deliver cylinders to the operator at an ergonomic height. The system features built to fit specifications for individual requirements and optimal use of space. Used in combination with cylinder carts, loading and unloading is a single person operation. With various drives and motor configurations available, the system provides a safe and secure storage area for cylinders.

- High density storage system utilizes overhead space for storage.
- Semi and fully automated systems available.
- Quick and easy access to cylinders.
- Motorized system stores and retrieves cylinders increasing workplace safety.
- Built to fit specifications.
- Protects cylinders from damage.
- Can operate and track inventory as an individual database or integrate with enterprise level ERP systems.

Safe Handling • Easy Access • Maximum Storage • Fast Retrieval • Small Footprint

800-326-4403 | [Sales@MaterialHandling-USA.com](mailto:Sales@MaterialHandling-USA.com)

# Cylinder Carousel



## Loading/Unloading



1. Place cylinder to be loaded on custom cylinder cart. Roll cart directly in front of carousel.

2. Using the push button controls, position desired carrier at proper height for loading. Roll cart under carrier to be loaded.

3. Loop provided nylon/chain straps around each end of cylinder journal and clip to carrier collars.

4. Using the push button controls, rotate the carousel up until the cylinder is raised off the cart. Roll cart away from carousel. Reverse procedure to unload.



### Cylinder Sling

**Collar:** slides back and forth on carrier, to accommodate any length of cylinder

**Collar Lock:** locks collar in desired place so no unwanted movement will occur

**Nylon Strap/Chain:** cylinder journal hangs securely on strap or chain, depending on weight of cylinder

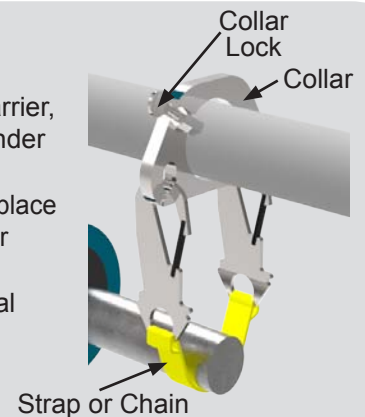

Vertical Cylinder Carousels can store multiple sizes and diameters of cylinders on a single system. Cylinders hang from the carousel carrier using a nylon/chain strap that is clipped to a cylinder collar. Multiple collars can be located anywhere on the carrier for various cylinder quantities and lengths up to the specified weight and off-balance limits of the carousel.

Safe Handling • Easy Access • Maximum Storage • Fast Retrieval • Small Footprint

800-326-4403 | Sales@MaterialHandling-USA.com