



# Mobile Aisle Systems

## Available Standard Colors



Textured Putty



Textured Dove Gray

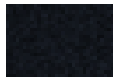

Textured Black



Textured Safety Yellow



Textured Cherry Red



Textured Regal Blue



Mirror Silver  
(Wire Shelving Only)



Smooth Office Gray



Smooth Reflective White

## Design Benefits & Features

Modular design facilitates easy assembly, allowing future reconfiguration and expansion.

Mobile carriages are rated to carry a maximum of 1000 lbs. per linear foot.

Mechanical-assist controls enable operator to move 10,000 lbs. with minimal effort.

All-track drive ensures uniform movement of carriages.

Modular platform provides for re-leveling rails after installation.

Accommodates all versatile V-Grip shelving and rack components.

## Space Utilization Advantages

Avoid the cost of new construction by doubling storage capacity in the same footprint.

Free valuable floor space for other operations without sacrificing storage capacity.

Integration with V-Grip maximizes flexibility to store small and bulk items together.

## Market Applications

Manufacturing - maintenance, parts, supplies, R&D, tool room.

Automotive - archival records, parts departments.

Healthcare - pharmacy, maintenance, supplies, radiology.

Education - athletic equipment, maintenance, supplies.

Military - parts/supplies, maintenance, vehicle service, flight maintenance, weapon racks.

Law enforcement - property and evidence, supplies, uniforms.

Retail - backroom storage, supplies.

Museum - artifact storage and security.

 **Material Handling USA**  
**800-326-4403**  
<https://www.mh-usa.com/>  
[Sales@MaterialHandling-USA.com](mailto:Sales@MaterialHandling-USA.com)

# Mobile Aisle Systems

Equipto's mobile aisle system combines the benefits of high-density storage with the flexibility of V-Grip Shelving, modular drawer and bulk rack. By reducing the number of

access aisles, you can save as much as 50% of your floor space or double your storage capacity in the same space you are currently using.

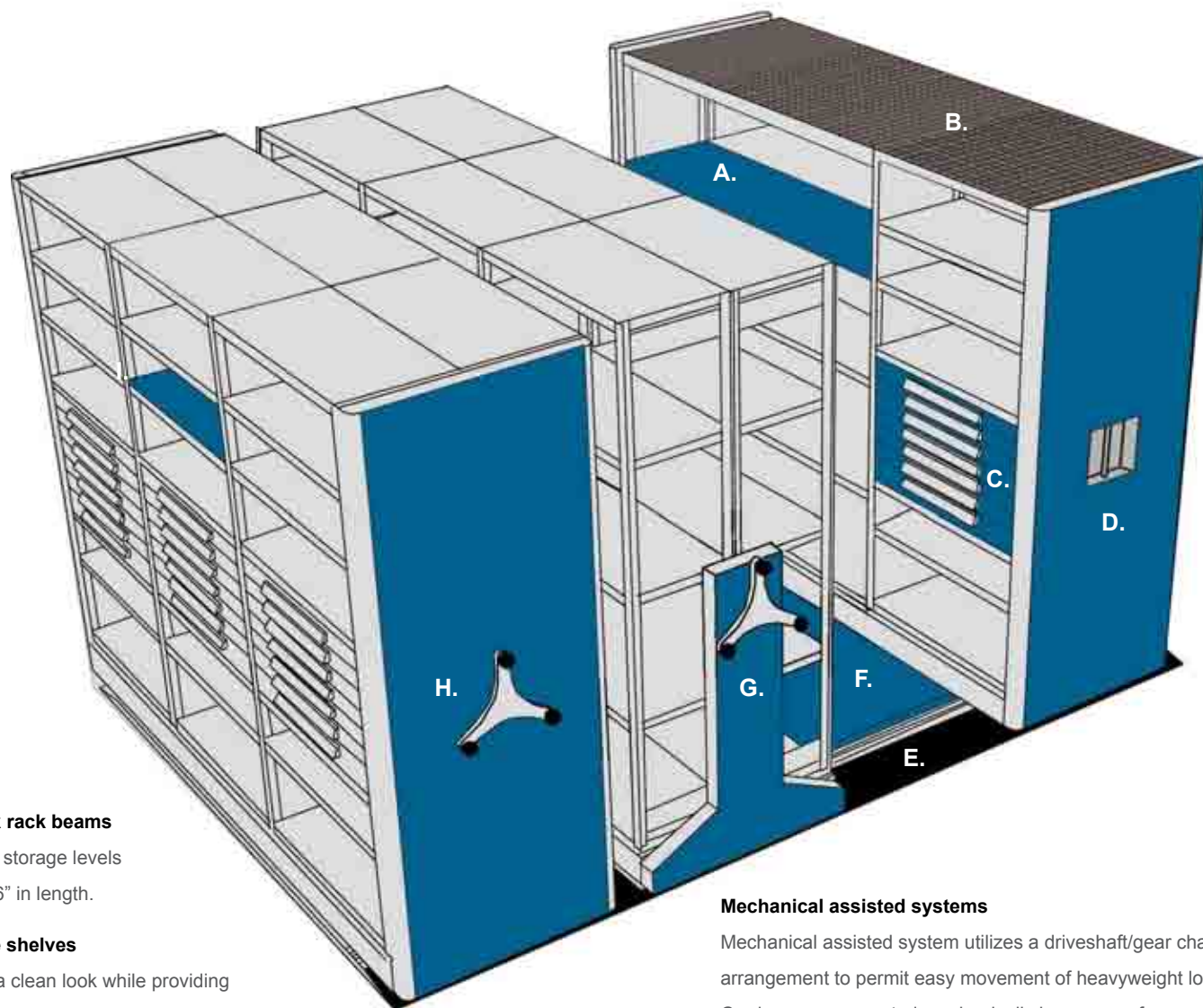

**A. Bulk rack beams**  
provide storage levels up to 96" in length.

**B. Wire shelves**  
Keeps a clean look while providing optimum flow of air and light.

**C. Modular drawers 18"D & 24"D**  
in 48 standard sizes and 200 or 400lb. capacity.

**D. Manual drive system**  
grab and pull function.

**E. Ramp**  
available in standard 12" or 24" to accommodate ADA requirements.

**F. Modular platform**  
surface mounted, leveled tracks and choice of decking.

**G. Open/Mechanical style drive column**  
cost effective while providing greater visibility of items stored in the mobile aisle system.

**H. Closed/Mechanical style drive**  
requires a minimal effort to move 10,000 lbs. of load.

**I. Heavy duty wire or solid shelves**  
**J. Fixed Carriage (not shown)**  
are mounted directly to the tracks or put on the floor using raised foot brackets.

## Mechanical assisted systems

Mechanical assisted system utilizes a driveshaft/gear chain arrangement to permit easy movement of heavyweight loads. Carriages are operated mechanically by means of an exclusive ergonomically designed hand wheel which prevents snagging clothing. It requires less strength and energy to operate. It's as easy to turn as the power steering in your car.

**A locking feature can be added for extra security.**

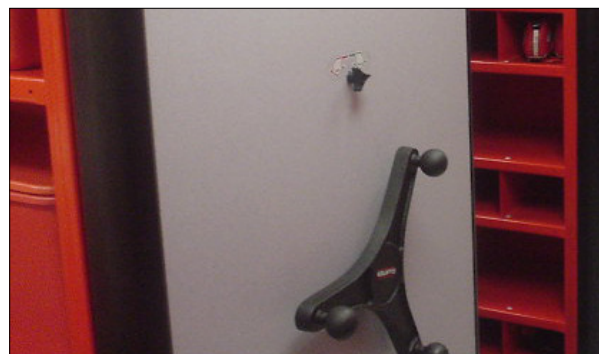

Mobile Aisle

# Designing your Mobile Aisle System

Every Mobile Aisle is a customer specific engineered product. A basic sketch of the area and mobile aisle system should be provided, indicating the overall dimensions of the area or room, including doorways, columns, and other obstructions.

Please provide basic size and shelving requirements to ensure accurate quoting.

Please contact Equipto to have a specific unit built to fit your needs.

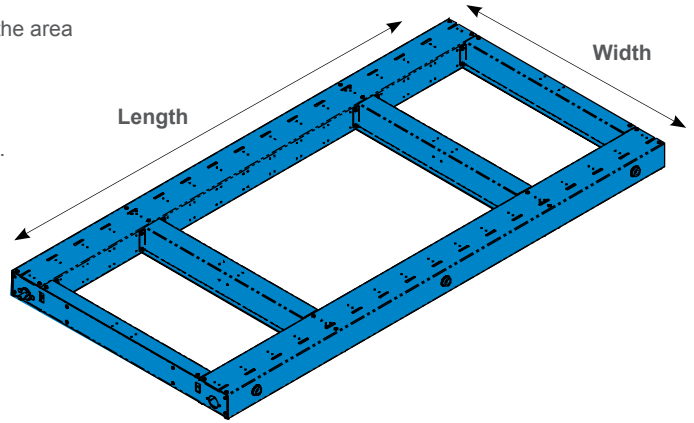

## 1st - Identify your available space and select your carriage size, decking, and shelving

Select the appropriate carriages by width and length

You have 3 options:

- Fixed Carriage
- Manual Mobile Carriage
- Mechanical Assist Mobile Carriage

### All Carriages

**Available Lengths:** (in feet)

3', 4' and 6' to 36' - not available in 5'

Manual Carriage does not exceed 12' length

**Available Widths:**

- Fixed Carriage  
12", 15", 18", 24", 30", 36", 48"
- Manual Carriage  
18", 24", 30", 36", 48"
- Mechanical Assist Carriage  
18", 24", 30", 36", 48", 60"

### Decking

Mobile Aisle Units offer two decking options:

- Tuffdeck (standard option - shown in image below)
- Plywood



### Shelving

Please refer to V-Grip Shelving starting on Page 5 for options.

## 2nd - Select your Drive Panel

Available Styles: Open and Closed - Open Style Drive Panel is the default selection.

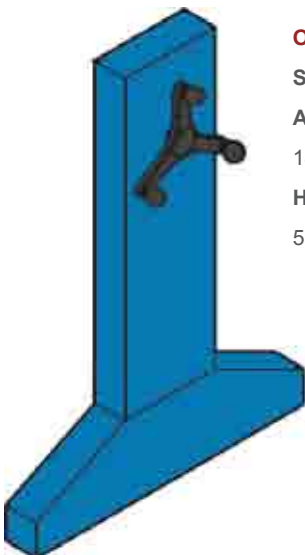

### Open/Mechanical Drive Panel

Steel Only

**Available widths:**

18", 24", 30", 36", 48", 60"

**Height:**

55"



### Closed/Mechanical Drive Panel

Steel or Laminate

**Available widths:**

18", 24", 30", 36", 48", 60"

**Height:**

Steel: 60", 78", 85", 90"

Laminate: 78", 85", 90"

60" widths are only available in 85" heights.

A standard color chart is available at the beginning of each section with a more detailed one on page 126.



Select your Drive Panel - cont'd



**Fixed Drive Panel**  
 Steel or Laminate  
**Available widths:**  
 12", 15", 18", 24", 30", 36", 48"  
**Height:**  
 Steel: 60", 78", 85", 90"  
 Laminate: 78", 85", 90"



**Manual Drive Panel**  
 Steel or Laminate  
**Available widths:**  
 18", 24", 30", 36", 48"  
**Height:**  
 Steel: 78", 85", 90"  
 Laminate: 78", 85", 90"

**Drive Shaft End Covers**

**Available Widths:**  
 12", 15", 18", 24", 30", 36", 48", 60"

**Note:** Finished End Covers are an inexpensive option to add-on to the end of the carriage to cover mechanical components (drive shaft) extending beyond carriage. This part can be used in place of an end panel but **WILL NOT** cover the shelving ends.

**\*Available for Fixed Carriages or opposite end of Manual or Mechanical apps.**

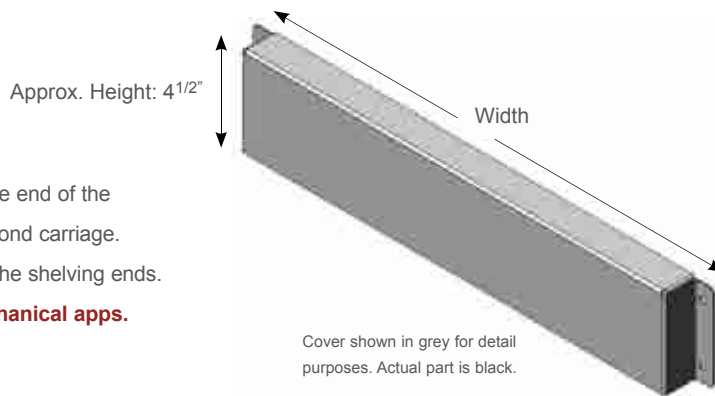

**Mobile Aisle Systems - Accessories**

**Anti Tip Brackets**

**Available Widths:**  
 18", 24", 30", 36", 48", 60"

**Use this guideline to determine if anti-tip brackets are required:**

- 18" wide carriage - use if shelving height is over 48"
- 24" wide carriage - use if shelving height is over 72"
- 30" wide carriage - use if shelving height is over 96"
- 36" wide carriage - use if shelving height is over 120"
- 48" wide carriage - use if shelving height is over 168"

**Use the following guideline to determine the quantity of anti-tip brackets needed:**

- One Required per Mechanical / Manual carriage 3'-6' in length
- Two Required per Mechanical / Manual carriage 7'-24' in length
- Three Required per Mechanical / Manual carriage 25'-36' in length

**Raised Foot Brackets**

For fixed carriages located on the floor.

**Raised Foot Bracket** - Order 2 per track.

**Hardware for Brackets** - Order 2 per bracket.

**Sprocket Options**

- Heavy load sprocket option
- Fast travel sprocket option
- Bumper extensions



**Deck Skirting**

**Available Length: 6'**

**Note:** Deck skirt covers the exposed areas at the end of the track. The skirts attach to the decking and are manufactured in 6ft. sections. The last section is cut to length in the field to match installation requirements.

**Locking Options**

**3 options:**

Normal or Keyed Alike

**Track Base Lock** - Keyed lock located on the carriage base, locking into the track. This is the only lock that can be used on manual carriages.

**MOBLOCK** - Keyed panel lock to secure carriage.

Available upon request. Typically used in last carriage.

Users can collapse the system, lock the last carriage, and the entire system is secured (must use closed-style shelving).

Ideal for high-security items.

**Panel Lock** - Safety Feature used to lock

hand wheel before entering an aisle.

Included with each mechanical drive panel (Not Keyed).

Panel lock shown in photo to the left.

Mobile Aisle