

EQUIPTO[®]

ONE DECISION • INFINITE SOLUTIONS

2019 Product Catalog



 **Material Handling USA**
800-326-4403
<https://www.mh-usa.com/>
Sales@MaterialHandling-USA.com

The industry leader in space storage and utilization products!



EQUIPTO's History

Recognized for innovation, quality and service, Equipto storage equipment is proudly manufactured in Tatamy, PA.

It all began in 1907, when Thomas M. Dunham began developing motorcycle headlights and sidecars in Aurora, Illinois. With the increase in automobile production, motorcycle parts soon were not in such high demand, so Equipto began producing body parts for Ford Motor Company's Model T Chassis. As the relationship with the car industry flourished, Dunham heard other needs within the automotive industry. One car dealer needed heavy-duty shelving to store large, heavy car parts and the idea for space storage and utilization was born.

Equipto can be your single source for the largest offering of Innovative Storage Solutions. Products we proudly manufacture include: Shelving and Racks, Modular Storage Cabinets, Small Parts Storage Systems, Mobile Aisle Storage Systems, Platforms and Mezzanines, Stairways and Crosswalks, Workcenters and Workbenches, Storage Cabinets, Carts, and Military Storage Systems. Equipto provides a limited lifetime warranty.

After more than 100 years, Equipto's customer base reaches across the U.S. and the world.

Equipto's Mission

EQUIPTO's mission is to become your preferred provider in the material storage market by offering a broad line of products and services that fulfill the needs of our customers with high-quality items manufactured in the USA. We will accomplish this by:

- 1. Breadth of products and Product flexibility and modularity**
- 2. Made in USA**
- 3. Broad range of colors available**
- 4. Installation services — full and supervisory**
- 5. Reliable, on-time delivery**
- 6. High quality of products**

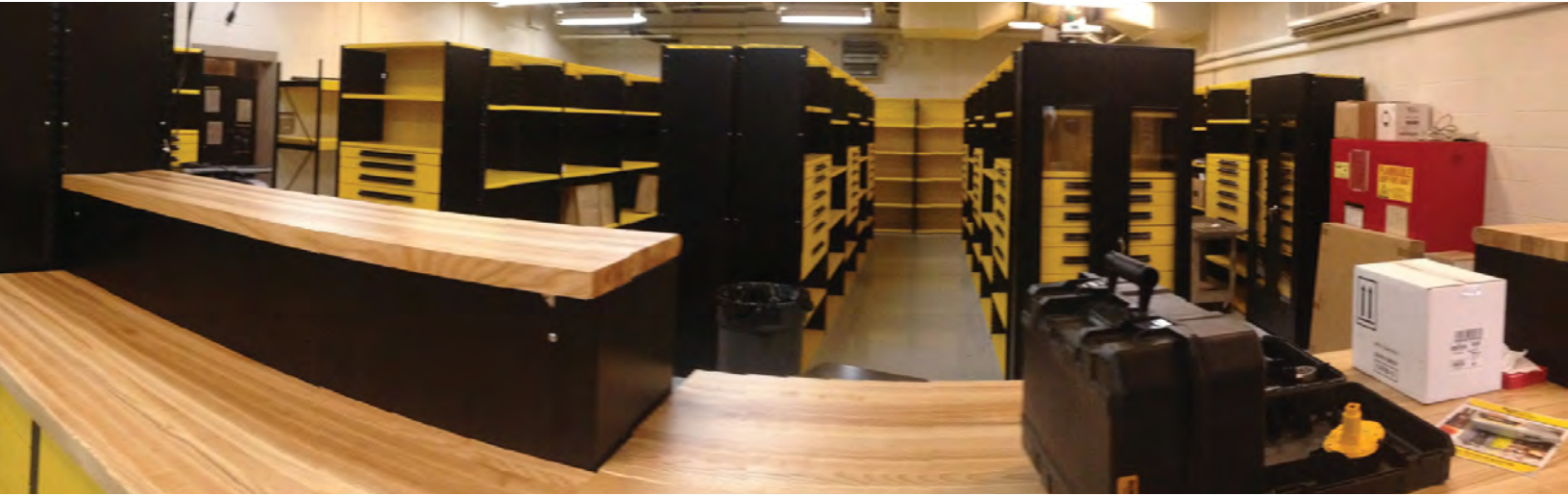

Shelving & Racks

1-35

Wire Shelving

36-39

Modular Drawer Cabinets

40-68

Small Parts Storage

69-75

Mobile Aisles

76-81

Clubstor

82-85

Platforms & Mezzanines

86-93

Stairways & Crosswalks

94-97

Workcenters & Workbenches

102-128

Storage Cabinets

129-139

Carts

140-143

Military Storage Solutions

144-149

Shelving & Racks



V-Grip™ Shelving

At the heart of Equipto's engineered space solutions is V-Grip, an industrial shelving system design that is unmatched in structural integrity and provides the industry's broadest selection of accessory components to meet virtually any application.

- V-Grip upright posts have an exclusive triangular design that maximizes load-bearing capability while providing a smooth front surface without unsightly holes or hardware.
- Combine V-Grip components to meet specific applications:
- Heavy-duty and medium-duty steel shelves
- Wire shelves for better flow of light and air
- Modular drawers in 48 different sizes with a capacity of 200 or 400 lbs.
- Use full or partial height dividers to create custom storage bins
- Bulk rack options including solid or wire shelves with spans up to 8 feet and capacities up to 3400 lbs. per level
- Back and end panels in any color
- Consult Equipto Inside Sales if you are in a seismic zone



Multiple connected V-Grip shelving units.

The Versatility of the V-Grip™ Upright Post

One post - multiple shelf options

Wire rack truss is designed with a rigid 3-point connection for maximum rigidity. (see page 11)



Wire shelf with integrated wire truss for maximum rigidity. (see page 6, 11 and 14)

Heavy duty 18 gauge solid steel shelf. (see page 14)

Bulk rack beams with reinforced drop-in wire decking. (see pages 22-25)

Bulk rack beams with heavy duty 18 gauge corrugated steel deck panels. (see pages 22-25)

Modular drawers come in 48 standard sizes in 200 lb. and 400 lb. capacity. (see pages 15-16)

A standard color chart is available on page 150.

V-Grip™ Shelving features the most efficient fastening principle known:

Corner shelf reinforcements with extruded studs insert easily into tapered slots in uprights. Shelf corner drops firmly over corner reinforcement and seats itself. Four-way, crossed tension minimizes deflection, and imparts superior strength and rigidity to the unit.



Double-flanged V-Grip uprights allow easy side-by-side assembly of shelving in rows, with the strongest configuration. Each flange of the upright supports a shelf from one adjoining unit only.

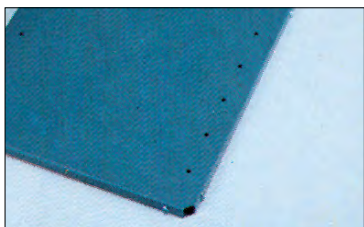

Reinforced, heavy-duty V-Grip shelves are constructed of 18-gauge steel, and double-flanged on all four sides for maximum strength and firmness.

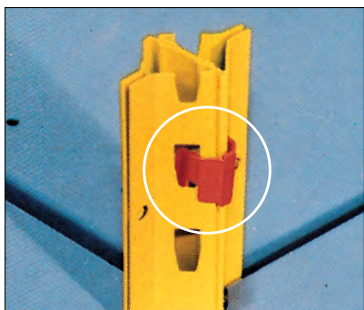

Common upright clamp provides back-to-back reinforcement.**



Optional drawers maximize cubic density in V-Grip shelving.

Versatile V-Grip uprights

Permit practical back-to-back assembly of shelving units, with the same, strong reinforcement that actually strengthens shelves and uprights, yet permits their easy adjustment, and features a capacity up to 9000 lbs.

Shelves adjust instantly on 1 1/2" centers, without disturbing shelves in adjoining units.

Four corner reinforcements insert into upright; shelf simply fits down over it, and locks into place.*

Tapered slots in uprights accept corner reinforcements for 4-way shelf support.

Double-flanged upright avoids two shelves from adjoining units placing stress on a single flange.



* Shown in color for clarity, actual part is zinc plated.

** Shown in color for clarity, actual part is galvanized steel.



V-Grip™ Solid Shelving - Open - 84”H

Depth	Width	Shelf Capacity	5 Shelves		7 Shelves		Extra Shelf
			Starter	Add-On	Starter	Add-On	
12” Depth							
12”	36”	650 lbs.	661-5S	661-5A	661-7S	661-7A	6230
12”	36”	940 lbs.	761-5S	761-5A	761-7S	761-7A	6230R
12”	42”	500 lbs.	661Y5S	661Y5A	661Y7S	661Y7A	6250
12”	42”	900 lbs.	761Y5S	761Y5A	761Y7S	761Y7A	6250R
12”	48”	430 lbs.	661W5S	661W5A	661W7S	661W7A	6240
12”	48”	700 lbs.	761W5S	761W5A	761W7S	761W7A	6240R
18” Depth							
18”	36”	700 lbs.	663-5S	663-5A	663-7S	663-7A	6231
18”	36”	1,170 lbs.	763-5S	763-5A	763-7S	763-7A	6231R
18”	42”	500 lbs.	663Y5S	663Y5A	663Y7S	663Y7A	6251
18”	42”	900 lbs.	763Y5S	763Y5A	763Y7S	763Y7A	6251R
18”	48”	440 lbs.	663W5S	663W5A	663W7S	663W7A	6241
18”	48”	740 lbs.	763W5S	763W5A	763W7S	763W7A	6241R
24” Depth							
24”	36”	721 lbs.	665-5S	665-5A	665-7S	665-7A	6232
24”	36”	1,000 lbs.	765-5S	765-5A	765-7S	765-7A	6232R
24”	42”	500 lbs.	665Y5S	665Y5A	665Y7S	665Y7A	6252
24”	42”	900 lbs.	765Y5S	765Y5A	765Y7S	765Y7A	6252R
24”	48”	450 lbs.	665W5S	665W5A	665W7S	665W7A	6242
24”	48”	720 lbs.	765W5S	765W5A	765W7S	765W7A	6242R
36” Depth							
36”	36”	670 lbs.	667-5S	667-5A	667-7S	667-7A	6234
36”	36”	790 lbs.	767-5S	767-5A	767-7S	767-7A	6234R

Shelves are 1 1/4” thick and adjustable in 1/2” increments. Add 1 5/8” to nominal shelving row width to determine total row width.

Note: Units can be ordered with 5–10 shelves. To order more shelves, change the suffix number to the desired quantity, e.g., 671-10S for 10 shelves.

V-Grip™ seismic area shelving available.



V-Grip™ Solid Shelving - Closed - 84”H

Depth	Width	Shelf Capacity	5 Shelves		7 Shelves		Extra Shelf
			Starter	Add-On	Starter	Add-On	
12” Depth							
12”	36”	650 lbs.	671-5S	671-5A	671-7S	671-7A	6230
12”	36”	940 lbs.	771-5S	771-5A	771-7S	771-7A	6230R
12”	42”	500 lbs.	671Y5S	671Y5A	671Y7S	671Y7A	6250
12”	42”	900 lbs.	771Y5S	771Y5A	771Y7S	771Y7A	6250R
12”	48”	430 lbs.	671W5S	671W5A	671W7S	671W7A	6240
12”	48”	700 lbs.	771W5S	771W5A	771W7S	771W7A	6240R
18” Depth							
18”	36”	700 lbs.	673-5S	673-5A	673-7S	673-7A	6231
18”	36”	1,170 lbs.	773-5S	773-5A	773-7S	773-7A	6231R
18”	42”	500 lbs.	673Y5S	673Y5A	673Y7S	673Y7A	6251
18”	42”	900 lbs.	773Y5S	773Y5A	773Y7S	773Y7A	6251R
18”	48”	440 lbs.	673W5S	673W5A	673W7S	673W7A	6241
18”	48”	740 lbs.	773W5S	773W5A	773W7S	773W7A	6241R
24” Depth							
24”	36”	721 lbs.	675-5S	675-5A	675-7S	675-7A	6232
24”	36”	1,000 lbs.	775-5S	775-5A	775-7S	775-7A	6232R
24”	42”	500 lbs.	675Y5S	675Y5A	675Y7S	675Y7A	6252
24”	42”	900 lbs.	775Y5S	775Y5A	775Y7S	775Y7A	6232R
24”	48”	450 lbs.	675W5S	675W5A	675W7S	675W7A	6242
24”	48”	720 lbs.	775W5S	775W5A	775W7S	775W7A	6242R
36” Depth							
36”	36”	690 lbs.	677-5S	677-5A	677-7S	677-7A	6234
36”	36”	790 lbs.	777-5S	777-5A	777-7S	777-7A	6234R

Add 1 5/8” to nominal shelving row width to determine total row width.

A standard color chart is available on page 150.

V-Grip™ shelving is made with 18-gauge high-strength steel.

V-Grip™ 20 Solid Shelving, Open, 84”H – 225 lb. load shelves

Depth	Shelf Width	Shelf Capacity	5 Shelves Starter	5 Shelves Add-On	7 Shelves Starter	7 Shelves Add-On	Extra Shelf
12” Depth							
12”	36”	225 lbs	261-5S	261-5A	261-7S	261-7A	2230
12”	42”	175LBS	261Y5S	261Y5A	261Y7S	261Y7A	2250
12”	48”	150LBS	261W5S	261W5A	261W7S	261W7A	2240
18” Depth							
18”	36”	225 lbs	263-5S	263-5A	263-7S	263-7A	2231
18”	42”	175LBS	263Y5S	263Y5A	263Y7S	263Y7A	2251
18”	48”	150LBS	263W5S	263W5A	263W7S	263W7A	2241
24” Depth							
24”	36”	225 lbs	265-5S	265-5A	265-7S	265-7A	2232
24”	42”	175LBS	265Y5S	265Y5A	265Y7S	265Y7A	2252
24”	48”	150LBS	265W5S	265W5A	265W7S	265W7A	2242
36” Depth							
36”	36”	225 lbs	267-5S	267-5A	267-7S	267-7A	2234

V-Grip™ 20

Equipto has expanded its V-Grip™ shelving line to now offer a lighter capacity and lower cost solution for your storage needs. V-Grip™ 20 uses 20-gauge steel for its shelves.



V-Grip™ 20 Solid Shelving, Closed, 84”H – 225 lb. load shelves

Depth	Shelf Width	Shelf Capacity	5 Shelves Starter	5 Shelves Add-On	7 Shelves Starter	7 Shelves Add-On	Extra Shelf
12” Depth							
12”	36”	225 lbs	271-5S	271-5A	271-7S	271-7A	2230
12”	42”	175LBS	271Y5S	271Y5A	271Y7S	271Y7A	2250
12”	48”	150LBS	271W5S	271W5A	271W7S	271W7A	2240
18” Depth							
18”	36”	225 lbs	273-5S	273-5A	273-7S	273-7A	2231
18”	42”	175LBS	273Y5S	273Y5A	273Y7S	273Y7A	2251
18”	48”	150LBS	273W5S	273W5A	273W7S	273W7A	2241
24” Depth							
24”	36”	225 lbs	275-5S	275-5A	275-7S	275-7A	2232
24”	42”	175LBS	275Y5S	275Y5A	275Y7S	275Y7A	2252
24”	48”	150LBS	275W5S	275W5A	275W7S	275W7A	2242
36” Depth							
36”	36”	225 lbs	277-5S	277-5A	277-7S	277-7A	2234

Extra wire shelves

Depth	2' wide	3' wide	4' wide	5' wide	6' wide
12”	6062	6063	6064	6065	6066
18”	6072	6073	6074	6075	6076
24”	6082	6083	6084	6085	6086

V-Grip™ Wire Shelving - 700 lb. capacity per shelf

Depth	Width	36”H with 2 shelves		48”H with 3 shelves		60”H with 4 shelves		72”H with 5 shelves		84”H with 6 shelves		96”H with 7 shelves		120”H with 9 shelves	
		Starter	Add-On	Starter	Add-On	Starter	Add-On	Starter	Add-On	Starter	Add-On	Starter	Add-On	Starter	Add-On
NEW! BEST VALUE SHELVING SIZES															
18”	36”	4533-02S	4533-02A	4534-03S	4534-03A	4535-04S	4535-04A	4536-05S	4536-05A	4537-06S	4537-06A	4538-07S	4538-07A	4539-09S	4539-09A
18”	48”	4543-02S	4543-02A	4544-03S	4544-03A	4545-04S	4545-04A	4546-05S	4546-05A	4547-06S	4547-06A	4548-07S	4548-07A	4549-09S	4549-09A
18”	72”	4563-02S	4563-02A	4564-03S	4564-03A	4565-04S	4565-04A	4566-05S	4566-05A	4567-06S	4567-06A	4568-07S	4568-07A	4569-09S	4569-09A
24”	36”	4633-02S	4633-02A	4634-03S	4634-03A	4635-04S	4635-04A	4636-05S	4636-05A	4637-06S	4637-06A	4638-07S	4638-07A	4639-09S	4639-09A
24”	48”	4643-02S	4643-02A	4644-03S	4644-03A	4645-04S	4645-04A	4646-05S	4646-05A	4647-06S	4647-06A	4648-07S	4648-07A	4649-09S	4649-09A
24”	72”	4663-02S	4663-02A	4664-03S	4664-03A	4665-04S	4665-04A	4666-05S	4666-05A	4667-06S	4667-06A	4668-07S	4668-07A	4669-09S	4669-09A
OTHER SHELVING SIZES AVAILABLE															
12” Depth															
12”	24”	4723-02S	4723-02A	4724-03S	4724-03A	4725-04S	4725-04A	4726-05S	4726-05A	4727-06S	4727-06A	4728-07S	4728-07A	4729-09S	4729-09A
12”	36”	4733-02S	4733-02A	4734-03S	4734-03A	4735-04S	4735-04A	4736-05S	4736-05A	4737-06S	4737-06A	4738-07S	4738-07A	4739-09S	4739-09A
12”	48”	4743-02S	4743-02A	4744-03S	4744-03A	4745-04S	4745-04A	4746-05S	4746-05A	4747-06S	4747-06A	4748-07S	4748-07A	4749-09S	4749-09A
12”	60”	4753-02S	4753-02A	4754-03S	4754-03A	4755-04S	4755-04A	4756-05S	4756-05A	4757-06S	4757-06A	4758-07S	4758-07A	4759-09S	4759-09A
12”	72”	4763-02S	4763-02A	4764-03S	4764-03A	4765-04S	4765-04A	4766-05S	4766-05A	4767-06S	4767-06A	4768-07S	4768-07A	4769-09S	4769-09A
18” Depth															
18”	24”	4523-02S	4523-02A	4524-03S	4524-03A	4525-04S	4525-04A	4526-05S	4526-05A	4527-06S	4527-06A	4528-07S	4528-07A	4529-09S	4529-09A
18”	60”	4553-02S	4553-02A	4554-03S	4554-03A	4555-04S	4555-04A	4556-05S	4556-05A	4557-06S	4557-06A	4558-07S	4558-07A	4559-09S	4559-09A
24” Depth															
24”	24”	4623-02S	4623-02A	4624-03S	4624-03A	4625-04S	4625-04A	4626-05S	4626-05A	4627-06S	4627-06A	4628-07S	4628-07A	4629-09S	4629-09A
24”	60”	4653-02S	4653-02A	4654-03S	4654-03A	4655-04S	4655-04A	4656-05S	4656-05A	4657-06S	4657-06A	4658-07S	4658-07A	4659-09S	4659-09A

Standard Color - Mirror silver. For other colors refer to Equipto color chart on page 150. *Not shown to scale.

V-Grip™ Spill Containment System

Utilizing our V-Grip™ wire shelving and our drip containment system, you can now have shelving fully capable of containing the occasional drip or spill from any fluid you need to store. At the same time, get the benefit from multiple levels to increase your storage capacity — no longer do you have to keep all of your fluid containers and drums on the floor. Available for four of our most popular shelf sizes.

Pre-configured wire shelving with spill containment trays (all 84" tall shelving units with 4 shelves and trays)

Width	Shelving Depth	Height	Starter	Add-On
36	18	84	43878-01S	43878-01A
36	24	84	43878-07S	43878-07A
48	18	84	43878-08S	43878-08A
48	24	84	43878-09S	43878-09A

Spill tray only

Part No.	Shelf Size	'A'-Length of pan	'B'-Width of pan	Capacity
43878-01	36 x 18	34	16	5 Gallons
43878-07	36 x 24	34	22	6.5 Gallons
43878-08	48 x 18	46	16	6.5 Gallons
43878-09	48 x 24	46	22	9 Gallons

Spill pan is 2¹/₄" deep and hooks under a wire shelf.

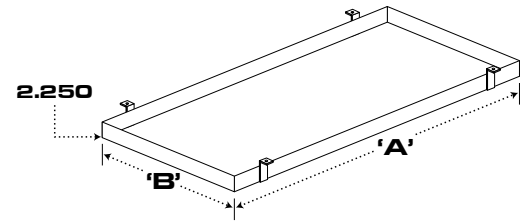

NEW!

Lateral Mobile Aisle with V-Grip™ Shelving

Make the most of limited space with Equipto's affordable, high-density system that dramatically increase storage capacity while still permitting immediate access to all storage areas. Movable-lateral systems consist of stationary shelving in the back row and movable shelving in the front row. The movable shelving units are mounted to mobile carriages that are easily moved from side to side on a heavy-duty track. This type of system is exceptionally flexible, can be easily expanded at any time, and provides fast access to multiple layers of storage.

- Buy complete or integrate with your existing storage equipment
- Lateral Track system creates two or three sliding rows of storage
- Mounted independently to the floor in front of new or existing equipment
- No aisles are required, maximum floor space is utilized
- Perfect for alcoves and limited spaces
- Bi-File (two-row) and Tri-File (three-row) high-density lateral sliding shelving systems are an affordable way to maximize storage capacity
- Double or triple the storage space compared to static shelving

The system works well with virtually any type of inventories/equipment and is effective in maximizing storage capacity along walls in narrow rooms or corridors. The concept of the high density lateral sliding shelving system is simple: two or three rows of storage equipment placed in nearly the same footprint where there was once only one!

Standard Shelving Units – 84"H x 18"D, overall height of 90"

Part Number	Description
#273-5-2-1-36M System	(2) 36"W Stationary V-Grip™ Closed Shelving Units, (1) Mobile 36"W Shelving Unit – Total width 72"
#273-5-3-2-36M System	(3) 36"W Stationary V-Grip™ Closed Shelving Units, (2) Mobile 36"W Shelving Unit – Total width 108"
#273-5-4-3-36M System	(4) 36"W Stationary V-Grip™ Closed Shelving Units, (3) Mobile 36"W Shelving Unit – Total width 144"



A standard color chart is available on page 150.

V-Grip™ Shelving & Drawer Units

84”H Closed preconfigured units with drawers:

Top shelf is a wire grid, as shown, and now required by code.



Drawers included: (1)-3”H, (1)-4 1/2”H, (1)-6”H & (1)-7 1/2”H

Drawer Depth	Drawer Width	Capacity Per Drawer	Starter Part No.	Add-On Part No.
18”	36”	200 lbs.	S4220VNS	S4220VNA
	36”	400 lbs.	S4220VHS	S4220VHA
	48”	400 lbs.	S4240VHS	S4240VHA
24”	36”	200 lbs.	S4230VNS	S4230VNA
	36”	400 lbs.	S4230VHS	S4230VHA
	48”	400 lbs.	S4250VHS	S4250VHA

Drawers included: (2)-4 1/2”H & (2)-6” H

Drawer Depth	Drawer Width	Capacity Per Drawer	Starter Part No.	Add-On Part No.
18”	36”	200 lbs.	S4221VNS	S4221VNA
	36”	400 lbs.	S4221VHS	S4221VHA
	48”	400 lbs.	S4241VHS	S4241VHA
24”	36”	200 lbs.	S4231VNS	S4231VNA
	36”	400 lbs.	S4231VHS	S4231VHA
	48”	400 lbs.	S4251VHS	S4251VHA



Drawers included: (2)-3”H, (1)-4 1/2”H & (1)-7 1/2”H

Drawer Depth	Drawer Width	Capacity Per Drawer	Starter Part No.	Add-On Part No.
18”	36”	200 lbs.	S4222VNS	S4222VNA
	36”	400 lbs.	S4222VHS	S4222VHA
	48”	400 lbs.	S4242VHS	S4242VHA
24”	36”	200 lbs.	S4232VNS	S4232VNA
	36”	400 lbs.	S4232VHS	S4232VHA
	48”	400 lbs.	S4252VHS	S4252VHA

Drawers included: (4)-4 1/2”H

Drawer Depth	Drawer Width	Capacity Per Drawer	Starter Part No.	Add-On Part No.
18”	36”	200lb	S4223VNS	S4223VNA
	36”	400lb	S4223VHS	S4223VHA
	48”	400lb	S4243VHS	S4243VHA
24”	36”	200lb	S4233VNS	S4233VNA
	36”	400lb	S4233VHS	S4233VHA
	48”	400lb	S4253VHS	S 4253VHA

*All units come with 4 solid shelves and one wire shelf. For additional shelves please see page 10.

No Divider Kits included, refer to pages 13, 14 and 15 for Divider Kit options.

A standard color chart is available on page 150.

V-Grip™ Shelving Bin Units

23 Openings 4-9"W x 9"H, 8-9"W x 12"H 9-12"W x 12"H, 2-18"W x 12"H		21 Openings 18-12"W x 12"H 3-12"W x 9"H		36 Openings 36-9"W x 9"H		66 Openings 60-6"W x 7 1/2"H 6-6"W x 9"H		78 Openings 72-6"W x 6"H 6-6"W x 9"H		
Depth :	Starter	Add-on	Starter	Add-on	Starter	Add-on	Starter	Add-on	Starter	Add-on
12"	914S	914A	906S	906A	905S	905A	904S	904A	903S	903A
18"	914DS	914DA	906DS	906DA	905DS	905DA	904DS	904DA	903DS	903DA
24"	914ES	914EA	906ES	906EA	905ES	905EA	904ES	904EA	903ES	903EA

All Units are 36" Wide and 84" in Height, for other available heights and widths contact Equipto Inside Sales.
Clear height of bin opening is 1 1/2" less than nominal height shown.

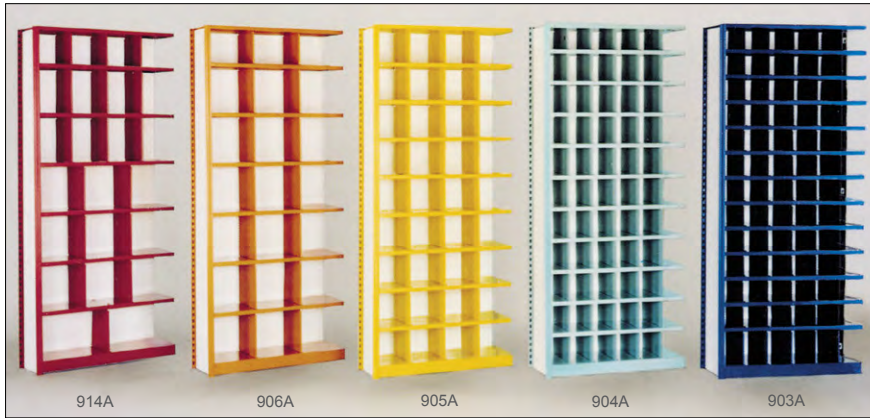

- Simple clip and divider system creates efficient bin compartments.
- Match right size opening to your parts and supplies
- Add doors for cleanliness and security
- Use bin units back-to-back, form dividing walls, use near desks, machines or benches



36 openings 9"W x 9"H		79 openings Assorted Sizes 12 Drawers 3 Compartments in each drawer		92 openings Assorted Sizes 24 Drawers 5 5/8"W x 3"H		72 drawers Drawers: 5 5/8"W x 3"H 6 Bins: 18"W		108 drawers 5 5/8"W x 3"H (324 Compartments)		
Depth :	Starter	Add-on	Starter	Add-on	Starter	Add-on	Starter	Add-on	Starter	Add-on
12"	907S	907A	910S	910A	911S	911A	920S	920A	919S	919A
18"	907DS	907DA	910DS	910DA	911DS	911DA	920DS	920DA	919DS	919DA
24"	907ES	907EA	-	-	-	-	-	-	-	-

All Units are 36" Wide and 84" in Height, for other available heights and widths contact Equipto Inside Sales.
Clear height of bin opening is 1 1/2" less than nominal height shown.

A standard color chart is available on page 150.

V-Grip™ Shelving Carts

- Instant mobility
- Open wire construction promotes high visibility, letting light and air pass freely
- Rugged and easy to use
- Handles the most demanding jobs
- All units have two brake and two rigid casters
- Casters are not recommended for units over 66”H



Equipto Carts are heavy duty to handle the toughest jobs. For Perimeter Bases only see page 15. Handle is standard reflective white.

V-Grip™ wire carts Casters are not recommended for units over 66”H

Depth	Width	Overall Height	Number of Shelves	With Standard Duty Casters (500 lbs. Capacity)	With Heavy Duty Casters (800 lbs. Capacity)	Additional Intermediate Shelves
18” Depth						
36”	42”	42”	2	4573	4573D	6073
		54”	3	4583	4583D	
		66”	4	4593	4593D	
48”	42”	42”	2	4574	4574D	6074
		54”	3	4584	4584D	
		66”	4	4594	4594D	
60”	42”	42”	2	4575	4575D	6075
		54”	3	4585	4585D	
		66”	4	4595	4595D	
72”	42”	42”	2	4576	4576D	6076
		54”	3	4586	4586D	
		66”	4	4596	4596D	
24” Depth						
36”	42”	42”	2	4673	4673D	6083
		54”	3	4683	4683D	
		66”	4	4693	4693D	
48”	42”	42”	2	4674	4674D	6084
		54”	3	4684	4684D	
		66”	4	4694	4694D	
60”	42”	42”	2	4675	4675D	6085
		54”	3	4685	4685D	
		66”	4	4695	4695D	
72”	42”	42”	2	4676	4676D	6086
		54”	3	4686	4686D	
		66”	4	4696	4696D	

A standard color chart is available on page 150.

V-Grip™ Shelving Components

Designed and engineered for maximum interchangeability, V-Grip™ components carry the quality assurance that has made Equipto the leader in industrial shelving systems. All parts and accessories are designed and produced by Equipto to integrate and form a solid compression fit resulting in a storage system that is guaranteed to deliver years of reliable service.

V-Grip™ shelving components

Structural Integrity comes from the integration of Equipto's exclusive V-Grip™ upright post and heavy-duty, compression-fit components. **When ordering V-Grip shelving by component, remember:**

- 1) To include 1 shelving end for each section of shelving and 1 shelving end to terminate each row.
- 2) Back sway braces and solid back panels can be shared between back-to-back units.
- 3) Closed shelving ends and solid back panels are available in all colors.
- 4) V-Grip™ shelves are heavy duty, 18-gauge steel and are provided with 4 corner clip reinforcements per shelf, which provide a friction fit to V-Grip™ upright posts.
- 5) To link open back to back shelves use 10381 clamps.
- 6) Consult Equipto Inside Sales if you are in a seismic zone.



16-Gauge

Upright posts (15/8" Wide)

Description	Part No.
36" High	5003
42" High	5035
48" High	5004
54" High	5031
60" High	5005
72" High	5006
78" High	5022
84" High	5007
90" High	5023
96" High	5008
108" High	5009
120" High	5010
144" High*	5012
180" High*	5015

*Posts over 144"H are spliced.



Heavy duty 18 ga solid shelves (D x W) 1 1/4" high

Description	Part No.
12" x 24"	6202
12" x 36"	6230
12" x 42"	6250
12" x 48"	6240
15" x 36"	6229
15" x 42"	6249
15" x 48"	6239
18" x 24"	6203
18" x 36"	6231
18" x 42"	6251
18" x 48"	6241
24" x 24"	6204
24" x 36"	6232
24" x 42"	6252
24" x 48"	6242
30" x 36"	810230-3
30" x 42"	6253
30" x 48"	6243
36" x 36"	6234
36" x 48"	6244



Reinforced heavy duty solid shelves

12" x 36"	6230R
12" x 48"	6240R
18" x 36"	6231R
18" x 48"	6241R
24" x 36"	6232R
24" x 48"	6242R
36" x 36"	6234R

Includes front and rear reinforcing bars.

Recommended for bottom 2 shelves on units over 8'.

VG Shelf	42"D x 36"W	810242-3
VG Shelf	36"D x 42"W	810250
VG Shelf	15"D x 24"W	810215-1

Center shelf reinforcements - 16 ga

36" Channel	10051
48" Channel	10052

Reinforcements - 13 ga

36" Front/RearEnd	10093
42" Front or Rear	9952
48" Front or Rear	10094
12" End	9630
18" End	9631
24" End	9632

Wire shelves (D x W)

Description (DxW)	700 lb. Standard color - Mirror Silver
-------------------	--

Shelf with truss included

12" x 24"	6062
12" x 36"	6063
12" x 48"	6064
12" x 60"	6065
12" x 72"	6066
18" x 24"	6072
18" x 36"	6073
18" x 48"	6074
18" x 60"	6075
18" x 72"	6076
24" x 24"	6082
24" x 36"	6083
24" x 48"	6084
24" x 60"	6085
24" x 72"	6086

Wire deck shelf panel

12" x 24"	6002
12" x 36"	6003
18" x 24"	6012
18" x 36"	6013
24" x 24"	6042
24" x 36"	6043
24" x 48"	—
36" x 48"	—
36" x 60"	—
48" x 48"	—

Wire shelf truss

24"	9472
36"	9473
48"	9474
60"	9475
72"	9476
96"	—



Open Shelving Ends ("VGOE + D + H")

Height	12" Deep	15" Deep	18" Deep	24" Deep	30" Deep	36" Deep	48" Deep
60" High (5')	VGOE1260	VGOE1560	VGOE1860	VGOE2460	VGOE3060	VGOE3660	VGOE4860
72" High (6')	VGOE1272	VGOE1572	VGOE1872	VGOE2472	VGOE3072	VGOE3672	VGOE4872
84" High (7')	VGOE1284	VGOE1584	VGOE1884	VGOE2484	VGOE3084	VGOE3684	VGOE4884
96" High (8')	VGOE1296	VGOE1596	VGOE1896	VGOE2496	VGOE3096	VGOE3696	VGOE4896
108" High (9')	VGOE12108	VGOE15108	VGOE18108	VGOE24108	VGOE30108	VGOE36108	VGOE48108
120" High (10')	VGOE12120	VGOE15120	VGOE18120	VGOE24120	VGOE30120	VGOE36120	VGOE48120
144" High (12')	VGOE12144	VGOE15144	VGOE18144	VGOE24144	VGOE30144	VGOE36144	VGOE48144
180" High (15')*	VGOE12180*	VGOE15180*	VGOE18180*	VGOE24180*	VGOE30180*	VGOE36180*	VGOE48180*

84" and 96" high Open Shelving Ends come with 2 upright posts and 2 end brace plates.

*Posts over 144" are spliced.

*If stacking (2) 8' Closed units, change end panel to VGCEX192 to cover all gaps.



Closed Shelving Ends ("VGCE + D + H")

Height	12" Deep	15" Deep	18" Deep	24" Deep	30" Deep	36" Deep	48" Deep
60" High (5')	VGCE1260	VGCE1560	VGCE1860	VGCE2460	VGCE3060	VGCE3660	VGCE4860
72" High (6')	VGCE1272	VGCE1572	VGCE1872	VGCE2472	VGCE3072	VGCE3672	VGCE4872
84" High (7')	VGCE1284	VGCE1584	VGCE1884	VGCE2484	VGCE3084	VGCE3684	VGCE4884
96" High (8')	VGCE1296	VGCE1596	VGCE1896	VGCE2496	VGCE3096	VGCE3696	VGCE4896
108" High (9')	VGCE12108	VGCE15108	VGCE18108	VGCE24108	VGCE30108	VGCE36108	VGCE48108
120" High (10')	VGCE12120	VGCE15120	VGCE18120	VGCE24120	VGCE30120	VGCE36120	VGCE48120
144" High (12')	VGCE12144	VGCE15144	VGCE18144	VGCE24144	VGCE30144	VGCE36144	VGCE48144
180" High (15')*	VGCE12180*	VGCE15180*	VGCE18180*	VGCE24180*	VGCE30180*	VGCE36180*	VGCE48180*

84" high Closed Shelving Ends come with 2 upright posts and 2 end brace plates. 96" high Closed Shelving Ends come with 2 upright posts and 3 end panels.

*Posts over 144" are spliced. Standard reflective white.

Back and end panels are available in all colors.



End Panels (VGEP + D + H)

Panel height	12" Deep	15" Deep	18" Deep	24" Deep	30" Deep	36" Deep	48" Deep
32-1/4" High	6786	6907	6787	6788	6911	6790	6921
35-1/4" High (3')	6796-36	6905	6797-36	6799-36	—	—	—
41-1/4" High (42")	—	—	6913	6914	—	—	—
42-3/4" High	6796	6906	6797	6798	6910	6800	6920
47-1/4" High (4')	6901	6908	6902	6903	6912	6904	6922
54"-60" High (5')	VGEP1260	VGEP1560	VGEP1860	VGEP2460	VGEP3060	VGEP3660	VGEP4860
72" High (6')	VGEP1272	VGEP1572	VGEP1872	VGEP2472	VGEP3072	VGEP3672	VGEP4872
78"-84" High (7')	VGEP1284	VGEP1584	VGEP1884	VGEP2484	VGEP3084	VGEP3684	VGEP4884
90"-96" High (8')	VGEP1296	VGEP1596	VGEP1896	VGEP2496	VGEP3096	VGEP3696	VGEP4896
108" High (9')	VGEP12108	VGEP15108	VGEP18108	VGEP24108	VGEP30108	VGEP36108	VGEP48108
120" High (10')	VGEP12120	VGEP15120	VGEP18120	VGEP24120	VGEP30120	VGEP36120	VGEP48120
144" High (12')	VGEP12144	VGEP15144	VGEP18144	VGEP24144	VGEP30144	VGEP36144	VGEP48144
180" High (15')	VGEP12180	VGEP15180	VGEP18180	VGEP24180	VGEP30180	VGEP36180	VGEP48180

Does not include upright posts.

Back and end panels are available in all colors.

Finishing end panels

Description (D x H)	Part No.
12" x 84"	7917-12
15" x 84"	7917-15
18" x 84"	7917-18
24" x 84"	7917-24
30" x 84"	7917-30

Flush fit to V-Grip. Row end covers all holes. Does not eliminate requirement for sway brace. Finishes off the end of a unit with an attractive solid panel. Standard color is reflective white regardless of shelf color.

Back Panels ("VGBP + W + H")

Back panel height	24" wide	36" wide	42" wide	48" wide
32-1/4" High	7583	7584	7586	7587
35-1/4" High (3')	7590-36	7588-36	7585-36	7589-36
41-1/4" High (42")	—	7591	—	7592
42-3/4" High	7590	7588	7585	7589
54"-60" High (5')	VGBP2460	VGBP3660	VGBP4260	VGBP4860
72" High (6')	VGBP2472	VGBP3672	VGBP4272	VGBP4872
78"-84" High (7')	VGBP2484	VGBP3684	VGBP4284	VGBP4884
90"-96" High (8')	VGBP2496	VGBP3696	VGBP4296	VGBP4896
108" High (9')	VGBP24108	VGBP36108	VGBP42108	VGBP48108
120" High (10')	VGBP24120	VGBP36120	VGBP42120	VGBP48120
144" High (12')	VGBP24144	VGBP36144	VGBP42144	VGBP48144
180" High (15')	VGBP24180	VGBP36180	VGBP42180	VGBP48180

Back and end panels are available in all colors.

V-Grip™ shelving components

Equipto's exclusive Wire Shelf design combines wire truss supports with a heavy-duty waterfall shelf to provide:

- Increased visibility of items on upper shelves
- Better flow of air, light, & sprinklers
- Capacity equal to heavy-duty 18 gauge solid steel shelves
- Shelves are 1 1/4" thick

Wire back grids (W x H)

Description	Part No.
24" x 36"	7546
36" x 36"	7556
42" x 36"	810442W1
48" x 36"	7557
60" x 36"	7558
72" x 36"	7559
96" x 36"	7560
24" x 48"	7547
36" x 48"	7561
42" x 48"	810442W2
48" x 48"	7562
60" x 48"	7563
72" x 48"	7564
96" x 48"	7566

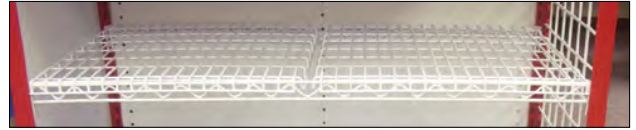
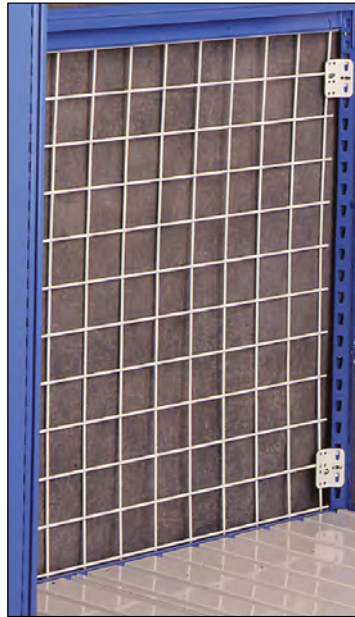

When using wire shelves in a closed-back shelving configuration, an additional back panel spacer and longer bolt is required to maintain clearance between the panel and the wire shelf.

Plastic spacer PN: 13219S

Truss head bolt, 10-24 x 1 3/4" PN: 13135
(one of each per back panel bracket)

Wire end grids (H x D)

Description	Part No.
36" x 12"	6780-03
36" x 18"	6781-03
36" x 24"	6782-03
36" x 36"	6783-03
36" x 48"	6784-03
48" x 12"	6795-04
48" x 18"	6791-04
48" x 24"	6792-04
48" x 36"	6793-04
48" x 48"	6794-04

Wire grids are reflective white.

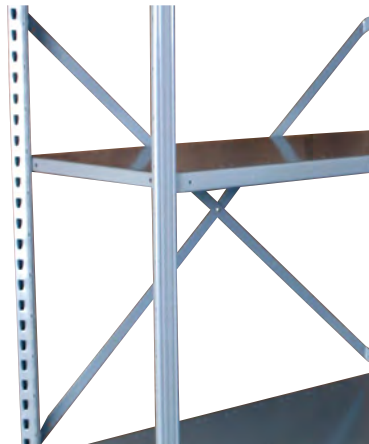
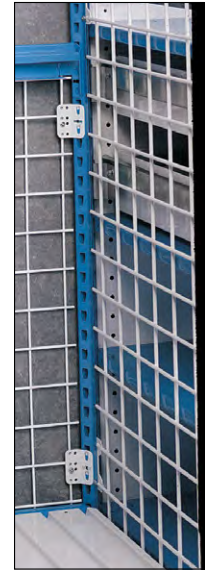

Back sway braces (width)

Description	Part No.
24" Back, pair	6418
36" Back, pair	6416
42" Back, pair	6419
48" Back, pair	6417

1 Req. up to 8 ft. / 2 Req. 9-15 ft.



End brace plates

Description	Part No.
12" End, pair	6412
15" End, pair	6411
18" End, pair	6413
24" End, pair	6414
30" End, pair	6406
36" End, pair	6415
48" End, pair	6410

For shelving up to 9' high, 2 pairs of plates are required. For shelving 9' to 12' high, a total of 3 pairs are required. For 13' high and above, 4 pairs are required.



Wire Hooks

Description	Part No.
4" L	7694-4
6" L	7694-6
8" L	7694-8
10" L	7694-10



Pull out reference shelves (D x W)

Description	Part No.
12" x 36"	6230RFS
12" x 48"	6240RFS
24" x 36"	6232RFS
24" x 48"	6242RFS

*Lightweight paper only.

V-Grip Roll-out Shelves

Size	Capacity	Part No.
36" x 18"	200 lbs.	S8603NR0
36" x 24"	200 lbs.	S8610NR0
36" x 18"	400 lbs.	S8603HR0
36" x 24"	400 lbs.	S8610HR0
48" x 18"	400 lbs.	S8661HR0
48" x 24"	400 lbs.	S8671HR0

Divider Kits – 18" Deep

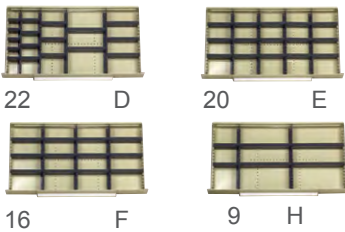

Divider Kits – 24" Deep

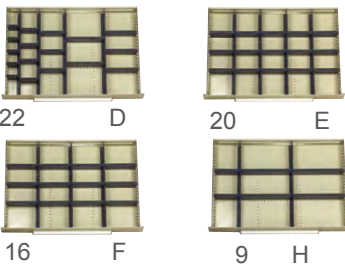

Important ordering considerations:

- When selecting divider kits select the correct height of partitions and dividers for specific drawers being ordered
- All dividers are smooth office gray in color

Preconfigured Divider kits for 36" wide drawers

For Drawer Width	For Drawer Height	Divider Set	18" Deep Divider Kit	24" Deep Divider Kit
36"	3"	D	4173D10	4183D10
	3"	E	4173E10	4183E10
	3"	F	4173F10	4183F10
	3"	H	4173H10	4183H10
	4 1/2"	D	4174D15	4184D15
	4 1/2"	E	4174E15	4184E15
	4 1/2"	F	4174F15	4184F15
	4 1/2"	H	4174H15	4184H15
	6" and up	D	4175D20	4185D20
	6" and up	E	4175E20	4185E20
	6" and up	F	4175F20	4185F20
	6" and up	H	4175H20	4185H20



Front floor bases (H x W)

Description	Part No.
25/8" x 36"	6803
25/8" x 42"	010136
25/8" x 48"	6805
4 1/8" x 36"	6804
4 1/8" x 42"	6807
4 1/8" x 48"	6806



Bin fronts

Description	Part No.
1 1/2" x 36" Bin Front	10514
1 1/2" x 48" Bin Front	10515
3 1/4" x 36" Bin Front	10516
3 1/4" x 48" Bin Front	10517

V-Grip Drawers

Maximize density with drawers for V-Grip

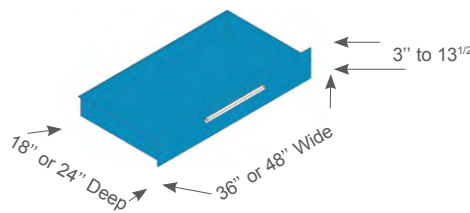

- 100% drawer extension
- 36 and 48 inch widths; 18 and 24 inch depths
- 200 and 400 lb. capacity



Modular Drawers in V-Grip Shelving

Depth (Front to Rear)	Height of Drawer Front	Inside Height	36" Wide 200 lb. Capacity	36" Wide 400 lb. Capacity	48" Wide 400 lb. Capacity
18"	3"	2"	S8603N	S8603H	S8661H
	4 1/2"	3 1/2"	S8604N	S8604H	S8662H
	6"	5"	S8605N	S8605H	S8663H
	7 1/2"	6 1/2"	S8606N	S8606H	S8664H
	9"	8"	S8601N	S8601H	S8665H
24"	10 1/2"	9 1/2"	S8602N	S8602H	S8666H
	12"	11"	S8607N	S8607H	S8667H
	13 1/2"	12"	S8608N	S8608H	S8668H
	3"	2"	S8610N	S8610H	S8671H
	4 1/2"	3 1/2"	S8611N	S8611H	S8672H
	6"	5"	S8612N	S8612H	S8673H
	7 1/2"	6 1/2"	S8613N	S8613H	S8674H
	9"	8"	S8615N	S8615H	S8675H
10 1/2"	9 1/2"	S8616N	S8616H	S8676H	
12"	11"	S8614N	S8614H	S8677H	
13 1/2"	12"	S8617N	S8617H	S8678H	

Note: All Drawer part numbers listed above do not include dividers.

Important ordering considerations:

- A shelf should be positioned above each group of drawers
- **Do not exceed 36" vertical spacing of continuous drawers**
- Handles include label holder, plastic cover strip and end caps
- Inside clear width: 36" - 31 7/8" / 48" - 43 1/4"
- Inside clear depth: 18" - 16 5/16" / 24" - 22 5/16"
- Standard installation of V-Grip shelving drawers leaves a 1/4" space between the drawer and the shelf directly above. To close this gap, select the appropriate filler strip. For 36"W drawers: 7702; for 48"W drawers: 7702-48.

A standard color chart is available on page 150.

Preconfigured Divider kits for 48" wide drawers

Width	For Drawer Height	Divider Set	18" Deep Divider Kit	24" Deep Divider Kit
48"	3"	D	4176D10	4186D10
	3"	E	4176E10	4186E10
	3"	F	4176F10	4186F10
	3"	H	4176H10	4186H10
	4 1/2"	D	4177D15	4187D15
	4 1/2"	E	4177E15	4187E15
	4 1/2"	F	4177F15	4187F15
	4 1/2"	H	4177H15	4187H15
	6" and up	D	4178D20	4188D20
	6" and up	E	4178E20	4188E20
	6" and up	F	4178F20	4188F20
	6" and up	H	4178H20	4188H20

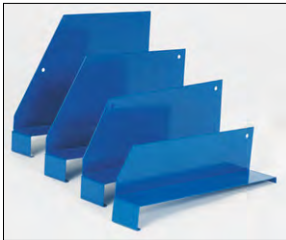

Sliding dividers (H x D)

Description	Part No.
2 3/4" x 12"	8110
4 1/4" x 12"	8111
5 3/4" x 12"	8112
7 1/4" x 12"	8113
2 3/4" x 18"	8103
4 1/4" x 18"	8104
5 3/4" x 18"	8105
7 1/4" x 18"	8106
2 3/4" x 24"	8114
4 1/4" x 24"	8115
5 3/4" x 24"	8116
7 1/4" x 24"	8117



Label holders

Description (H x W)	Part No.
1 1/8" x 34" Label Holder	6615
1 1/8" x 46" Label Holder	6613
1" x 6" Plastic (for wire only)	6620

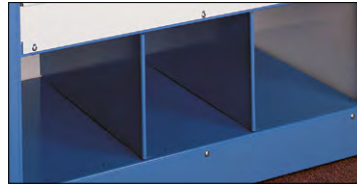

Full height shelf dividers (H x D)

Description	Part No.
2" x 12"	8049
4 1/2" x 12"	8018
6" x 12"	8019
7 1/2" x 12"	8020
9" x 12"	8021
10 1/2" x 12"	8022
12" x 12"	8023
13 1/2" x 12"	8024
15" x 12"	8025
16 1/2" x 12"	8026
2" x 18"	8093
4 1/2" x 18"	8090
6" x 18"	8094
7 1/2" x 18"	8095
9" x 18"	8096
10 1/2" x 18"	8097
12" x 18"	8098
13 1/2" x 18"	8099
15" x 18"	810313
16 1/2" x 18"	8091
18" x 18"	8092
6" x 24"	8119
7 1/2" x 24"	8120
9" x 24"	8121
10 1/2" x 24"	8122
12" x 24"	8123
13 1/2" x 24"	8124
15" x 24"	8125
16 1/2" x 24"	8126
21" x 24"	8129
22 1/2" x 24"	810306-2
24" x 24"	810301
25 1/2" x 24"	810324
28 1/2" x 24"	810324-1
37 1/2" x 24"	810324-2
48" x 24"	810306-3
10 1/2" x 36"	8133
12" x 36"	8134
Speediclip	10226

(Speediclip holds shelf dividers to shelves above and below.)

18" Deep



24" Deep

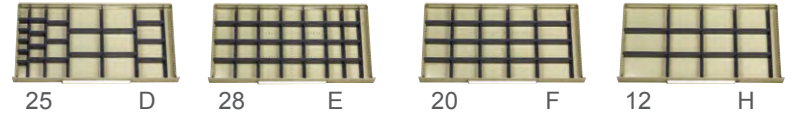

Important ordering considerations:

- When selecting divider kits select the correct height of partitions and dividers for specific drawers being ordered
- All dividers are smooth office gray in color

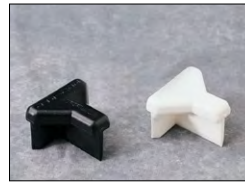

Close the top of any V-Grip Bulk Rack upright. Easy to attach - simply tap its triangular base into the upright. May also be used as floor glide to protect all floors. Made of high-impact plastic, it will withstand any load within the capacity of the upright itself.

Top/bottom cap

Description	Part No.
Top or Bottom Cap/White	10177W
Top or Bottom Cap/Black	10177B

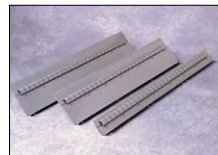

Ribbed and slotted partitions fit easily into drawers, running the full depth of the drawer from front-to-back. Adjustable in 3/4" increments, they may be used alone, or with dividers. Metal screws are supplied for fastening to drawer bottoms.

Partitions

Partition Height	To Fit Drawer Height	To Fit 18" Deep Drawers	To Fit 24" Deep Drawers
2"	3"	8780N	8790N
3"	4 1/2"	8781N	8791N
4 1/2"	6" and up	8782N	8792N

- All partitions are smooth office gray in color

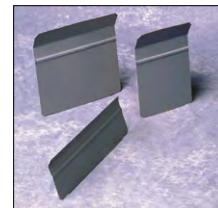

To further expand the possibilities in creating your own drawer design, we offer a variety of individual dividers. Use them with front-to-back partitions to make compartments of all sizes. Spaces across drawers; each 3/4" wide
36" wide drawers — 40 spaces
48" wide drawers — 53 spaces

Individual dividers

Divider Width	Spaces	For 3" High Drawers	For 4 1/2" High Drawers	For 6" High Drawers and Up
3 3/32"	4	8834	8844	8854
4 11/16"	6	8835	8845	8855
6 9/32"	8	8836	8846	8856
7 7/8"	10	8837	8847	8857
9 7/16"	12	8838	8848	8858
12 11/16"	16	8839	8849	8859

- All dividers are smooth office gray in color

NEW!

Hinged double doors for V-Grip™ shelving

Add security and visibility to your storage material with full-height, mesh door kits. Doors provide a steel hasp for securing with customer-provided padlock.

Wire Mesh Doors for Shelving

Part Number	Description
19126	Wire Mesh Door, 2'W x 6'H
19127	Wire Mesh Door, 2'W x 7'H
19128	Wire Mesh Door, 2'W x 8'H
19136	Wire Mesh Door, 3'W x 6'H
19137	Wire Mesh Door, 3'W x 7'H
19138	Wire Mesh Door, 3'W x 8'H
19146	Wire Mesh Door, 4'W x 6'H
19147	Wire Mesh Door, 4'W x 7'H
19148	Wire Mesh Door, 4'W x 8'H

Color is Gray Powder Coat. Cannot be used with drawers in shelves.



Wire dividers for wire shelves
(H x D)

Description	Part No.
9" x 18"	8101
9" x 24"	8102



Plastic containers (W x D x H)

Color	Part No.
White (11" x 22 ³ / ₄ " x 7")	8501W
Yellow (11" x 22 ³ / ₄ " x 7")	8501Y
Blue (11" x 22 ³ / ₄ " x 7")	8501B
Clear (11" x 22 ³ / ₄ " x 7")	8501C
Red (11" x 22 ³ / ₄ " x 7")	8501R
Black (11" x 22 ³ / ₄ " x 7")	8501BLK
Container Lid (11" x 22 ³ / ₄ ")	8502
(3 Across fits 36" wide shelf)	
White (8 ¹ / ₄ " x 22 ³ / ₄ " x 6")	8512W
Yellow (8 ¹ / ₄ " x 22 ³ / ₄ " x 6")	8512Y
Blue (8 ¹ / ₄ " x 22 ³ / ₄ " x 6")	8512B
(4 Across fits 36" wide shelf)	



Add mobility to any V-Grip™ steel or wire shelving or rack 18" or more deep. Capacity 800 lbs. per unit.

Mobile Perimeter base (Add 6" to height)

Depth	36" wide	48" wide	60" wide	72" wide	96" wide
18"	4699C13	4699C14	4699C15	4699C16	4699C18
24"	4699C23	4699C24	4699C25	4699C26	4699C28
30"	4699C03	4699C04	4699C05	4699C06	4699C08
36"	4699C33	4699C34	4699C35	4699C36	4699C38
48"	4699C43	4699C44	4699C45	4699C46	4699C48

Note: Includes 2 swivel and 2 stationary heavy duty casters. when ordering V-Grip™ uprights with mobile base, add suffix "TU" after part number for upright. Ex: 5005TU. Not recommended over 66"H.



Doors for shelving (W x H)
Lock and key included

Description	Part No.
36" x 34 ¹ / ₂ "	18036*
36" x 42"	18043*
36" x 72"	18035-72
36" x 78"	18035-78*
36" x 84"	18035*
36" x 96"	18035-96*
42" x 84"	44979A
48" x 34 ¹ / ₂ "	18436*
48" x 42"	18443*
48" x 72"	18435-72
48" x 78"	18435-78*
48" x 84"	18435*
48" x 96"	18435-96*

*For Quick View doors, add QV to the end of the part number (see page 130).

Handles (white)

18"D	11580
24"D	11581
30"D	811030
36"D	44080-03

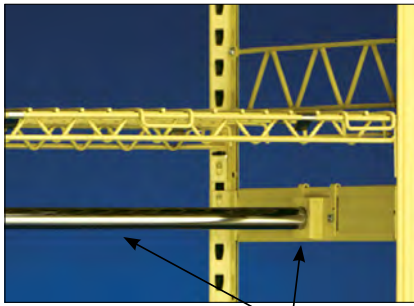

Hanger bar & bracket

Hanger bar and bracket

(Includes rod, brackets and one support channel) (D x W)

Description	Part No.
12" x 36"	9753-12
12" x 48"	9754-12
12" x 60"	9755-12
12" x 72"	9756-12
18" x 36"	9753-18
18" x 48"	9754-18
18" x 60"	9755-18
18" x 72"	9756-18
24" x 36"	9753-24
24" x 48"	9754-24
24" x 60"	9755-24
24" x 72"	9756-24
36" x 36"	9753-36
36" x 48"	9754-36
36" x 60"	9755-36
36" x 72"	9756-36

Order one end support channel to each section to finish row.

12" deep	7731
18" deep	7732
24" deep	7733
36" deep	7734

Note: 150 lb. cap. distributed load.

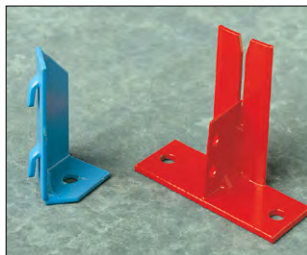

Splicer

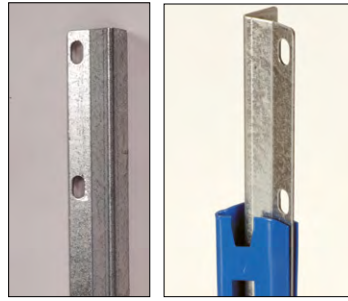

Description	Part No.
To splice 2 V-Grip posts	5568
For Bulk Rack above V-Grip shelving	5568BS
For Bulk Rack above Bulk Rack	5566



10381 - Common upright clamp
13037 - Dart clip

Floor anchor fastens shelving to floor for increased stability. order no. **7695L** (left hand) or no. **7695R** (right hand). Seismic floor anchor (center) **190317A**.

Brackets (flush front 7700 L & R and corner 7698 L & R) allow easy attachment of angle iron / catwalks to V-Grip™ uprights.

Miscellaneous parts

Description	Part No.
Common upright clamp	10381
Corner reinforcement clip	7680
Dart clip for beams	13037
Dart clip for label holder	13041
Back panel bracket for closed shelving	10388
Bolt and nut (3/16" x 1/4")	13001
Bolt and nut (3/16" x 3/8")	13000
Panel clip	10332
Speedy clip	10226
Upright splicer	5568
Corner bracket L.H.	7698L
Corner bracket R.H.	7698R
Flush bracket, L.H.	7700L
Flush bracket, R.H.	7700R
Back-to-back bracket for wire shelving	7750
#Rod (3/16" x 79")	9705
#Rod (3/16" x 85")	9720
Aisle safety rail, 3'	10043V
Aisle safety rail, 4'	10044V
Floor anchor L.H.	7695L
Floor anchor R.H.	7695R
V-grip floor plates	9826
Aisle bracket L.H.	7693L
Aisle bracket R.H.	7693R
Foot/leveler	13149
V-grip™ top mount bracket, left	7692L
V-grip™ top mount bracket, right	7692R
18" D handle (white)	11580
24" D handle (white)	11581
30" D handle (white)	811030
36" D handle (white)	44080-03

Seismic accessories

Description	Part No.
Back panel bracket, pair	190301U
Back brace, pair, 36"	190302U
Back brace, pair, 42"	190308U
Back brace, pair, 48"	190303U
Back brace, pair, 96"	190309U
End sway brace, pair, 12"	190304U
End sway brace, pair, 18"	190305U
End sway brace, pair, 24"	190306U
End sway brace, pair, 36"	190307U
End sway brace, pair, 48"	190310U
Floor anchor-center	190317A
Floor anchor (left hand)	190319A
Floor anchor (right hand)	190320A
Shelf locking clip	10231

Double entry beams (2 required)

Description	Part No.
24" Long	811724A
36" Long	9403
42" Long	811742A
48" Long	9404

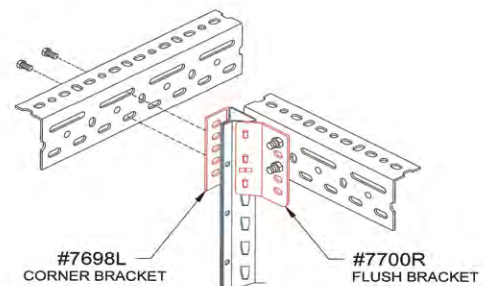

NEW!

We have developed a Parachute Storage Bar for V-Grip™ Shelving in numerous configurations.

Part Number	Description
20053	3ft Bar w/ 3 18" Hangers
20054	4ft Bar w/ 4 18" Hangers
20056	6ft Bar w/ 6 18" Hangers
20060	Extra 18" Parachute Hanger, 55lb capacity

NEW!

Louver Rails for V-Grip™ Shelving

Part Number	Description	Capacity
20113	3ft Louvered rail	180lb
20114	4ft Louvered rail	150lb

Individual Bins

Part Number	Description	# of Bins to fill Rail	
		3ft	4ft
050-0200Y	5" x 4-1/8" x 3" 8lb capacity bin	8	10
	050-0220Y	7-3/8" x 4-1/8" x 3" 10lb capacity bin	8
050-0230Y	10-4/8" x 5-1/2" x 5" 30lb capacity bin	6	8



Bins on Rail



4ft Bar w/ 4 Hangers



18" Parachute Hanger

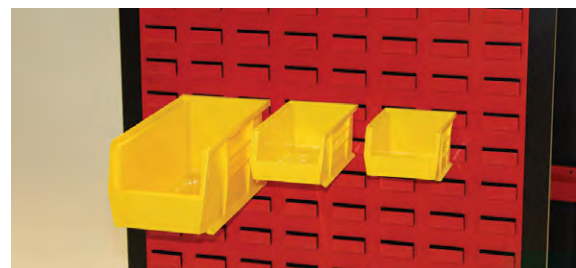

050-0230Y 050-0220Y 050-0200Y

V-Grip™ Workcenters

36"H units have 33" for drawers (2 shelves)

42"H units have 39" for drawers (2 shelves)

*Minimum 2 shelves – 1 at bottom & 1 in middle = 3" (if you add more, minus 1-1/2" for each shelf out of the total height for drawers).
*If you add a door kit you must deduct 1-1/2" from the total height for drawers and add (4) tek screws 13114. Also add 3" more (in addition to the 2" overhang) onto your top depth to account for the door frame.



Uprights

36"H	5003
42"H	5035

End Brace Plates

18"D	6413
24"D	6414

Back Brace

36"W	6416
42"W	6417

Shelves

18"	36"	6231
18"	48"	6241
24"	36"	6232
24"	48"	6242

To fill in space between shelf and drawer use fillers 36"W 7702 or 48"W 7702-48.

Back Panels

Depth	Width	Part
36"	35-1/4"	7588-36
36"	41-1/4"	810436-5
48"	35-1/4"	7589-36
48"	41-1/4"	810448-7

End Panels

Depth	Height	Part
18"	35-1/4"	6797-36
18"	41-1/4"	810518-4
24"	35-1/4"	6799-36
24"	41-1/4"	810524-5

Hardwood Tops

When selecting a top, remember your shelving is always 1-5/8" longer than your nominal size, so your top must also be longer than a standard size top in the catalog.

Part No.	Depth	Width	Thickness	Edge	For V-Grip Sizes (some overhang front and back)
9111517-001	20"	38"	1-3/4"	Bullnose-Front	18" x 37-5/8"
9111516-001	20"	74"	1-3/4"	Bullnose-Front	18" x 73-5/8" (2-36"W units)
9111514A001	26"	111"	1-3/4"	Bullnose-Front	24" x 109-7/8" (3-36"W units)
9111539-002	24"	37-3/4"	1-3/4"	Square	24" x 37-5/8"
9111626-002	24"	74"	1-3/4"	Square	24" x 73-5/8" (2-36"W units)
9111601-002	36"	50"	1-3/4"	Square	36" x 49-5/8"

To splice tops together use 51721S. You can also mix with these standard size All Square edge tops with your total run as long as 1 top is 1-5/8" longer.

Brackets for Top Attachments

Drawers at top	7643LK	7643RK
NO drawers or shelf at top	7692L	7692R

Need 2L & 2R per starter, 1L & 1R per add-on.

Part No.	Depth	Width	Thickness	Edge
9111576-002	24"	72"	1-3/4"	Square
9111521A001	36"	72"	1-3/4"	Square
9111526-001	36"	108"	1-3/4"	Square

If a top is not available in the size you need, contact Purchasing or Wisconsin Bench to get a quote. Make sure you remember to add 1-5/8" or more onto your nominal total width and also if you want all square or bullnose on one side that will determine your depth — all square can be exact depth (some overhang is recommended), bullnose on one edge will require additional minimum of 1" added onto nominal to account for bullnose receding and exposing the top of the upright. If you have units back to back then you should add a minimum of 2" to the overall depth and remember to specify if you want all square or bullnose on two edges.

V-Grip™ Bulk Rack

V-Grip Bulk Rack is designed to accommodate longer spans and heavier loads than conventional shelving. Bulk Rack beams engage V-Grip upright posts providing a rigid connection. Bulk Rack levels are designed to carry load capacities from 1500 lbs. to 3000 lbs. per level, depending on beam span length and deck material used.

The units to the right are shown with optional wire decking.



Three level bulk rack with decking

Depth	Height	48" Wide		60" Wide		72" Wide		96" Wide	
		Starter	Add-on	Starter	Add-on	Starter	Add-on	Starter	Add-on
Standard duty (from 1100 lbs. to 1500 lbs. For specific capacities see chart on page 24)									
15"	60"	1005D41S	1005D41A	1005D51S	1005D51A	1005D61S	1005D61A	—	—
	72"	1006D41S	1006D41A	1006D51S	1006D51A	1006D61S	1006D61A	—	—
18"	60"	1005D48S	1005D48A	1005D58S	1005D58A	1005D68S	1005D68A	—	—
	72"	1006D48S	1006D48A	1006D58S	1006D58A	1006D68S	1006D68A	—	—
	84"	1007D48S	1007D48A	1007D58S	1007D58A	1007D68S	1007D68A	—	—
24"	60"	1005D42S	1005D42A	1005D52S	1005D52A	1005D62S	1005D62A	—	—
	72"	1006D42S	1006D42A	1006D52S	1006D52A	1006D62S	1006D62A	—	—
	84"	1007D42S	1007D42A	1007D52S	1007D52A	1007D62S	1007D62A	—	—
30"	60"	1005D40S	1005D40A	1005D50S	1005D50A	1005D60S	1005D60A	—	—
	72"	1006D40S	1006D40A	1006D50S	1006D50A	1006D60S	1006D60A	—	—
	84"	1007D40S	1007D40A	1007D50S	1007D50A	1007D60S	1007D60A	—	—
36"	60"	1005D43S	1005D43A	1005D53S	1005D53A	1005D63S	1005D63A	—	—
	72"	1006D43S	1006D43A	1006D53S	1006D53A	1006D63S	1006D63A	—	—
	84"	1007D43S	1007D43A	1007D53S	1007D53A	1007D63S	1007D63A	—	—
48"	60"	1005D44S	1005D44A	1005D54S	1005D54A	1005D64S	1005D64A	—	—
	72"	1006D44S	1006D44A	1006D54S	1006D54A	1006D64S	1006D64A	—	—
	84"	1007D44S	1007D44A	1007D54S	1007D54A	1007D64S	1007D64A	—	—
Medium duty (from 1500 lbs. to 2000 lbs. For specific capacities see chart on page 24)									
15"	60"	1015D41S	1015D41A	1015D51S	1015D51A	1015D61S	1015D61A	1015D81S	1015D81A
	72"	1016D41S	1016D41A	1016D51S	1016D51A	1016D61S	1016D61A	1016D81S	1016D81A
18"	60"	1015D48S	1015D48A	1015D58S	1015D58A	1015D68S	1015D68A	1015D88S	1015D88A
	72"	1016D48S	1016D48A	1016D58S	1016D58A	1016D68S	1016D68A	1016D88S	1016D88A
	84"	1017D48S	1017D48A	1017D58S	1017D58A	1017D68S	1017D68A	1017D88S	1017D88A
24"	60"	1015D42S	1015D42A	1015D52S	1015D52A	1015D62S	1015D62A	1015D82S	1015D82A
	72"	1016D42S	1016D42A	1016D52S	1016D52A	1016D62S	1016D62A	1016D82S	1016D82A
	84"	1017D42S	1017D42A	1017D52S	1017D52A	1017D62S	1017D62A	1017D82S	1017D82A
30"	60"	1015D40S	1015D40A	1015D50S	1015D50A	1015D60S	1015D60A	1015D80S	1015D80A
	72"	1016D40S	1016D40A	1016D50S	1016D50A	1016D60S	1016D60A	1016D80S	1016D80A
	84"	1017D40S	1017D40A	1017D50S	1017D50A	1017D60S	1017D60A	1017D80S	1017D80A
36"	60"	1015D43S	1015D43A	1015D53S	1015D53A	1015D63S	1015D63A	1015D83S	1015D83A
	72"	1016D43S	1016D43A	1016D53S	1016D53A	1016D63S	1016D63A	1016D83S	1016D83A
	84"	1017D43S	1017D43A	1017D53S	1017D53A	1017D63S	1017D63A	1017D83S	1017D83A
48"	60"	1015D44S	1015D44A	1015D54S	1015D54A	1015D64S	1015D64A	1015D84S	1015D84A
	72"	1016D44S	1016D44A	1016D54S	1016D54A	1016D64S	1016D64A	1016D84S	1016D84A
	84"	1017D44S	1017D44A	1017D54S	1017D54A	1017D64S	1017D64A	1017D84S	1017D84A
Heavy duty (over 2000 lbs. For specific capacities see chart on page 24)									
15"	60"	1025D41S	1025D41A	1025D51S	1025D51A	1025D61S	1025D61A	1025D81S	1025D81A
	72"	1026D41S	1026D41A	1026D51S	1026D51A	1026D61S	1026D61A	1026D81S	1026D81A
18"	60"	1025D48S	1025D48A	1025D58S	1025D58A	1025D68S	1025D68A	1025D88S	1025D88A
	72"	1026D48S	1026D48A	1026D58S	1026D58A	1026D68S	1026D68A	1026D88S	1026D88A
	84"	1027D48S	1027D48A	1027D58S	1027D58A	1027D68S	1027D68A	1027D88S	1027D88A
24"	60"	1025D42S	1025D42A	1025D52S	1025D52A	1025D62S	1025D62A	1025D82S	1025D82A
	72"	1026D42S	1026D42A	1026D52S	1026D52A	1026D62S	1026D62A	1026D82S	1026D82A
	84"	1027D42S	1027D42A	1027D52S	1027D52A	1027D62S	1027D62A	1027D82S	1027D82A
30"	60"	1025D40S	1025D40A	1025D50S	1025D50A	1025D60S	1025D60A	1025D80S	1025D80A
	72"	1026D40S	1026D40A	1026D50S	1026D50A	1026D60S	1026D60A	1026D80S	1026D80A
	84"	1027D40S	1027D40A	1027D50S	1027D50A	1027D60S	1027D60A	1027D80S	1027D80A
36"	60"	1025D43S	1025D43A	1025D53S	1025D53A	1025D63S	1025D63A	1025D83S	1025D83A
	72"	1026D43S	1026D43A	1026D53S	1026D53A	1026D63S	1026D63A	1026D83S	1026D83A
	84"	1027D43S	1027D43A	1027D53S	1027D53A	1027D63S	1027D63A	1027D83S	1027D83A
48"	60"	1025D44S	1025D44A	1025D54S	1025D54A	1025D64S	1025D64A	1025D84S	1025D84A
	72"	1026D44S	1026D44A	1026D54S	1026D54A	1026D64S	1026D64A	1026D84S	1026D84A
	84"	1027D44S	1027D44A	1027D54S	1027D54A	1027D64S	1027D64A	1027D84S	1027D84A

DECKING: "D" in catalog number represents corrugated steel decking. Substitute "W" for drop in wire decking (available in 24", 36", & 48" depths) or "-" for no decking.

Four level bulk rack with solid decking

Depth	Height	48" Wide		60" Wide		72" Wide		96" Wide	
		Starter	Add-on	Starter	Add-on	Starter	Add-on	Starter	Add-on
Standard duty (from 1100 lbs. to 1500 lbs. For specific capacities see chart on page 24)									
NEW! 18"	96"	1008D48S	1008D48A	1008D58S	1008D58A	1008D68S	1008D68A	—	—
	120"	1010D48S	1010D48A	1010D58S	1010D58A	1010D68S	1010D68A	—	—
24"	96"	1008D42S	1008D42A	1008D52S	1008D52A	1008D62S	1008D62A	—	—
	120"	1010D42S	1010D42A	1010D52S	1010D52A	1010D62S	1010D62A	—	—
30"	96"	1008D40S	1008D40A	1008D50S	1008D50A	1008D60S	1008D60A	—	—
	120"	1010D40S	1010D40A	1010D50S	1010D50A	1010D60S	1010D60A	—	—
36"	96"	1008D43S	1008D43A	1008D53S	1008D53A	1008D63S	1008D63A	—	—
	120"	1010D43S	1010D43A	1010D53S	1010D53A	1010D63S	1010D63A	—	—
48"	96"	1008D44S	1008D44A	1008D54S	1008D54A	1008D64S	1008D64A	—	—
	120"	1010D44S	1010D44A	1010D54S	1010D54A	1010D64S	1010D64A	—	—
Medium duty (from 1500 lbs. to 2000 lbs. For specific capacities see chart on page 24)									
NEW! 18"	96"	1018D48S	1018D48A	1018D58S	1018D58A	1018D68S	1018D68A	1018D88S	1018D88A
	120"	1020D48S	1020D48A	1020D58S	1020D58A	1020D68S	1020D68A	1020D88S	1020D88A
24"	96"	1018D42S	1018D42A	1018D52S	1018D52A	1018D62S	1018D62A	1018D82S	1018D82A
	120"	1020D42S	1020D42A	1020D52S	1020D52A	1020D62S	1020D62A	1020D82S	1020D82A
30"	96"	1018D40S	1018D40A	1018D50S	1018D50A	1018D60S	1018D60A	1018D80S	1018D80A
	120"	1020D40S	1020D40A	1020D50S	1020D50A	1020D60S	1020D60A	1020D80S	1020D80A
36"	96"	1018D43S	1018D43A	1018D53S	1018D53A	1018D63S	1018D63A	1018D83S	1018D83A
	120"	1020D43S	1020D43A	1020D53S	1020D53A	1020D63S	1020D63A	1020D83S	1020D83A
48"	96"	1018D44S	1018D44A	1018D54S	1018D54A	1018D64S	1018D64A	1018D84S	1018D84A
	120"	1020D44S	1020D44A	1020D54S	1020D54A	1020D64S	1020D64A	1020D84S	1020D84A
Heavy duty (over 2000 lbs. For specific capacities see chart on page 24)									
NEW! 18"	96"	1028D48S	1028D48A	1028D58S	1028D58A	1028D68S	1028D68A	1028D88S	1028D88A
	120"	1030D48S	1030D48A	1030D58S	1030D58A	1030D68S	1030D68A	1030D88S	1030D88A
24"	96"	1028D42S	1028D42A	1028D52S	1028D52A	1028D62S	1028D62A	1028D82S	1028D82A
	120"	1030D42S	1030D42A	1030D52S	1030D52A	1030D62S	1030D62A	1030D82S	1030D82A
30"	96"	1028D40S	1028D40A	1028D50S	1028D50A	1028D60S	1028D60A	1028D80S	1028D80A
	120"	1030D40S	1030D40A	1030D50S	1030D50A	1030D60S	1030D60A	1030D80S	1030D80A
36"	96"	1028D43S	1028D43A	1028D53S	1028D53A	1028D63S	1028D63A	1028D83S	1028D83A
	120"	1030D43S	1030D43A	1030D53S	1030D53A	1030D63S	1030D63A	1030D83S	1030D83A
48"	96"	1028D44S	1028D44A	1028D54S	1028D54A	1028D64S	1028D64A	1028D84S	1028D84A
	120"	1030D44S	1030D44A	1030D54S	1030D54A	1030D64S	1030D64A	1030D84S	1030D84A

Five level bulk rack with solid decking

Depth	Height	48" Wide		60" wide		72" wide		96" wide	
		Starter	Add-on	Starter	Add-on	Starter	Add-on	Starter	Add-on
Standard duty (from 1100 lbs. to 1500 lbs. For specific capacities see chart on page 24)									
36"	180"	1012D43S	1012D43A	1012D53S*	1012D53A*	1012D63S*	1012D63A*	—	—
48"	180"	1012 D44S	1012D44A	1012D54S*	1012D54A*	1012D64S*	1012D64A*	—	—
Medium duty (from 1500 lbs. to 2000 lbs. For specific capacities see chart on page 24)									
36"	180"	1022D43S	1022D43A	1022D53S	1022D53A	1022D63S	1022D63A	1022D83S	1022D83A
48"	180"	1022D44S	1022D44A	1022D54S	1022D54A	1022D64S	1022D64A	1022D84S	1022D84A

*Posts for units over 12' high are spliced.

DECKING: "D" in Catalog number represents Corrugated Steel Decking. Substitute "W" for drop in Wire Decking or "-" for no decking.

Bulk Rack shelving options



Solid beams

- 3 lugs on each beam connector locks securely to post
- Adjusts on 1 1/2" centers



Drop In Wire decking
Capacity to 2667 lbs.

- Lets air, light and water pass through
- Offset between beam and wire shelving is .2625+/- or just over 1/4"

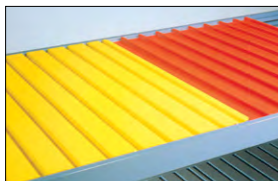

Solid shelf

Capacity to 2763 lbs.

- Solid corrugated steel
- Versatile: Use ridge side up or flat channeled surface

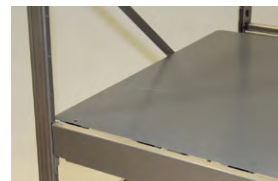

Flat Steel Decking

Capacity to 4815 lbs.

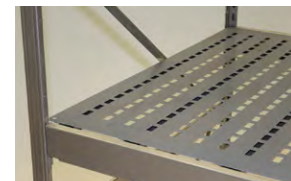

Perforated Steel Decking

Capacity to 4815 lbs.

- Provides stronger decking with drainage / perforations

A standard color chart is available on page 150.

NEW!

Bulk Rack 2" Bin Fronts

851614	48" long
851615	60" long
851616	72" long

NEW!

Corrugated Decking Panels

Width	15" Deep	18" Deep	24" Deep	30" Deep	36" Deep	48" Deep
24"	16018	16001	16002	16019	16003	16004
30"	16020	16010	16022	16021	16023	16024

Flat & Perforated Steel Decking

Length	Depth of Rack	Capacity (lbs)	Flat Number	Perforated Number
4'	15"	2407	16314F	16314PF
5'	15"	3003	16315F	16315PF
6'	15"	3611	16316F	16316PF
7'	15"	4213	16317F	16317PF
8'	15"	4815	16318F	16318PF
4'	18"	2029	16374F	16374PF
5'	18"	2537	16375F	16375PF
6'	18"	3044	16376F	16376PF
7'	18"	3552	16377F	16377PF
8'	18"	4059	16378F	16378PF
4'	24"	1852	16324F	16324PF
5'	24"	2310	16325F	16325PF
6'	24"	2778	16326F	16326PF
7'	24"	3241	16327F	16327PF
8'	24"	3704	16328F	16328PF
4'	30"	1435	16354F	16354PF
5'	30"	1794	16355F	16355PF
6'	30"	2152	16356F	16356PF
7'	30"	2511	16357F	16357PF
8'	30"	2870	16358F	16358PF
4'	36"	1196	16334F	16334PF
5'	36"	1495	16335F	16335PF
6'	36"	1794	16336F	16336PF
7'	36"	2093	16337F	16337PF
8'	36"	2392	16338F	16338PF
4'	48"	1192	16344F	16344PF
5'	48"	1490	16345F	16345PF
6'	48"	1788	16346F	16346PF
7'	48"	2086	16347F	16347PF
8'	48"	2384	16348F	16348PF

Bulk Rack shelving decking options

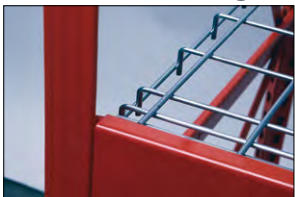

Drop In Wire decking

Capacity to 2667 lbs.

- Lets air, light and water pass through
- Offset between beam and wire shelving is .2625+/- or just over 1/4"

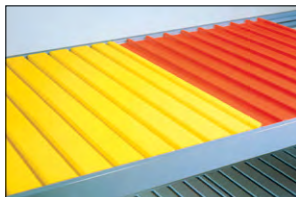

Solid shelf

Capacity to 2763 lbs.

- Solid corrugated steel
- Versatile: Use ridge side up or flat channeled surface

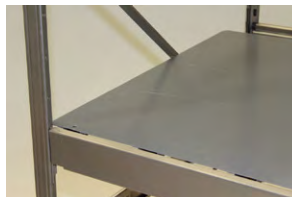

Flat Steel Decking

Capacity to 4815 lbs.



Perforated Steel Decking

Capacity to 4815 lbs.

- Provides stronger decking with drainage / perforations

Bulk Rack load capacities



Load Capacities of drop in wire grid decking (for solid beams)

Length	Depth of rack	Capacity(lbs.)	Part No.
4'	24"	1500	16324W
5'	24"	1500	16325W
6'	24"	2250	16326W
7'	24"	2625	16327W
8'	24"	3000	16328W
4'	36"	1500	16334W
5'	36"	1500	16335W
6'	36"	2250	16336W
7'	36"	2625	16337W
8'	36"	3000	16338W
4'	48"	1500	16344W
5'	48"	1500	16345W
6'	48"	2250	16346W
7'	48"	2625	16347W
8'	48"	3000	16348W

Note: To determine shelf level capacity with decking, use beam or decking capacity, whichever is less.

Load Capacities of corrugated steel decking (for solid beams)

Length	Depth of rack	Capacity(lbs.)	Part No.
4'	15"	2407	16314
5'	15"	3003	16315
6'	15"	3611	16316
7'	15"	4213	16317
8'	15"	4815	16318
4'	24"	1852	16324
5'	24"	2310	16325
6'	24"	2778	16326
7'	24"	3241	16327
8'	24"	3704	16328
4'	30"	1435	16354
5'	30"	1794	16355
6'	30"	2152	16356
7'	30"	2511	16357
8'	30"	2870	16358
4'	36"	1196	16334
5'	36"	1495	16335
6'	36"	1794	16336
7'	36"	2093	16337
8'	36"	2392	16338
4'	48"	1192	16344
5'	48"	1490	16345
6'	48"	1788	16346
7'	48"	2086	16347
8'	48"	2384	16348

Note: To determine shelf level capacity with decking, use beam or decking capacity, whichever is less.

Rack Capacities

Rack end capacity is not a factor under most circumstances. However, if you intend to space beam levels unusually far apart, check your plan to insure that the cumulative load on the lower portions of each rack end is within the limits shown on this chart. Rack ends are designed with a safety factor of 1.92. Horizontal beams are designed with a safety factor of 1.65.

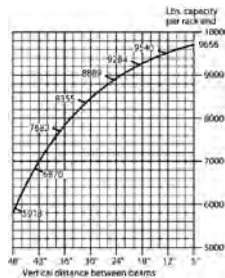

Load Capacities of V-Grip Bulk Rack solid beams

Light Duty*

Width	Beam Height	Capacity(lbs.)	Part No.
4'	25/8"	1460	9434
5'	25/8"	1208	9435
6'	25/8"	1163	9436

Medium Duty*

Width	Beam Height	Capacity(lbs.)	Part No.
4'	27/8"	2112	9444
5'	27/8"	1690	9445
6'	27/8"	1622	9446
7'	33/4"	1557	830284M
8'	33/4"	1557	9448

Heavy Duty*

Width	Beam Height	Capacity(lbs.)	Part No.
4'	31/2"	3454	9454
5'	31/2"	2763	9455
6'	31/2"	2630	9456
7'	33/4"	2667	830284H
8'	33/4"	2667	9458

*Capacities are in lbs. per pair of beams

Flow Rack

- Extremely versatile rack on which multiple size containers or batteries can be stored
- Tracks allow for easy movement
- Each flow track is equipped with a front to keep products from sliding off
- Flow racks can be angled for gravity feed

Part No.	Description	Size (D x W x H)
FR1	5 Shelves/15 Span Tracks	48" x 48" x 84"
FR2	4 Shelves/12 Span Tracks	48" x 48" x 72"
FR3	4 Shelves/12 Span Tracks	36" x 60" x 72"
ST1536	One Roller Track with Hardware	36" x 15"
ST1548	One Roller Track with Hardware	48" x 15"



A standard color chart is available on page 150.

V-Grip™ Bulk Rack shelving components

Designed with versatility to fit your needs

- Accessories to expand units higher
- Ability to mix rack with shelving
- Built-in capability for future expansion
- Plywood or other decking supplied by user: 5/8" thick

Rack Accessories

Description	Part No.
Clamp for fastening units back-to-back; 2 needed per pair of frames	10381
Dart clip for locking down beams — 2 needed	13037
Plastic label holder fits V-Grip wire	6620

Rack Ends

Depth	5' High	6' High	7' High	8' High	10' High	12' High	15' High
	Part No.	Part No.	Part No.	Part No.	Part No.	Part No.	Part No.
15"	9304	9309	9314	9319	9329	—	9345*
18"	9333	9336	9337	9338	9339	9340	9341*
24"	9301	9306	9311	9316	9326	9332	9342*
30"	9305	9310	9315	9320	9330	—	9346*
36"	9302	9307	9312	9317	9327	9333	9343*
48"	9303	9308	9313	9318	9328	9334	9344*

*Posts over 12' are spliced.

Rack Ends with nutserts for mounting to caster base

Depth	5' High	6' High
24"	9301TU	9306TU
30"	—	9310TU
36"	9302TU	9307TU

Perimeter caster base (pg.17).

Use both for Particle Board

Tie Bars for solid beams and Steel and Wire Decking

Depth	Part No.	Depth	Part No.
15"	6521	24"	9420
18"	6528	30"	830815
24"	6522	36"	9421
30"	6525	48"	9422
36"	6523		
48"	6524		

Order 1 per pair of 4' or 5' beams;
2 per pair of 6' or 8' beams.

Order 3 per pair of 4' or 5' beams;
4 per pair of 6' or 8' beams.



Divider Arm 8008A (must add extra beam)

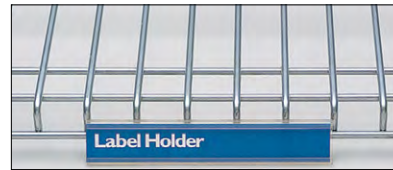

Label Holder

A neat and easy way to identify records or supplies.
Part No. 6620.

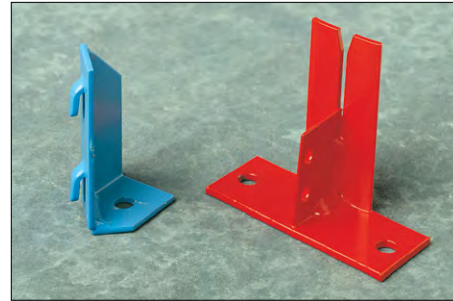

7695 L&R

190317A

Floor Anchors (one for each post)

Fasten racks to floor for increased stability.

(Must be used when bottom beam is more than 12" from floor.)

7695 L&R (optional 190317A Seismic Anchor for Center)

Close the top of any V-Grip Bulk Rack upright.

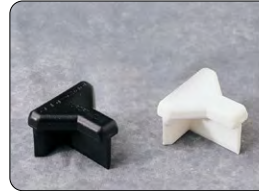

Easy to attach - simply tap its triangular base into the upright. May also be used as floor glide to protect all floors. Made of high-impact plastic, it will withstand any load within the capacity of the upright itself.

Top/bottom cap

Description	Part No.
Top or Bottom Cap/White	10177W
Top or Bottom Cap/Black	10177B

Flush Front and Corner Brackets

Attach catwalks to racks.

7698 L&R

7700 L&R

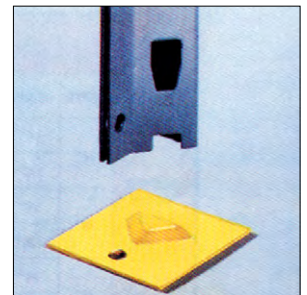
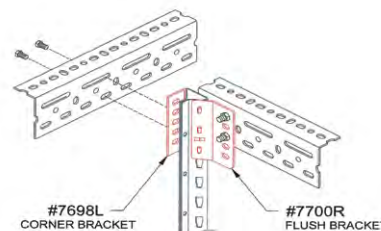

Foot Plate

Fits under uprights to protect linoleum or wood floors, or to act as shim on uneven floors.
Part No. 9826

60" Wide V-Grip™ Bulk Rack Drawers

30"D x 60"W x 84"H with 3 Levels (solid steel decking), Closed Ends/Backs

1. Shelving unit components

Starter Unit - 4200BHS Includes

QTY	Part #	Description
4	5007	84" V-Grip Upright
4	810530	30"x42-3/4" End Panel
2	810460-1	60" x 42" Flat Back Panel
6	9435	60" Light Duty Beam
3	16355	30"Dx60"W Solid Decking Level
3	13114	Tek Screw
3	6525	30" Tie Bar
2	190319A	LH Seismic Anchor
2	190320A	RH Seismic Anchor
1	831515-2	SATS Spacer Bar 5ft Pair

Add-on Unit - 4200BHA Includes

QTY	Part #	Description
2	5007	84" V-Grip Upright
2	810530	30"x42-3/4" End Panel
2	810460-1	60" x 42" Flat Back Panel
6	9435	60" Light Duty Beam
3	16355	30"Dx60"W Solid Decking Level
3	13114	Tek Screw
3	6525	30" Tie Bar
2	190317A	Center Seismic Anchor
1	831515-2	SATS Spacer Bar 5ft Pair

There are **3** restrictions that will have to be followed when placing these drawer bodies in the bulk rack unit. **One**, to minimize the gap between the top of the drawer front and the bottom of the beam, a **4-1/2" or larger drawer must** be placed at the top position. **Two**, the light duty beams must be used in the 60" drawer in shelving applications. This is due to the height of the beam. **Three**, spacer beams are required; they will go in between the drawer configuration located approximately 36" from the bottom. #831515-2 comes in pairs assembled like the beams - one in front and one in back. You only need one pair per unit.



2.

60"W Drawers 400 lb. Capacity

PART NUMBER	DESCRIPTION
8653-10S	3"H Drawer (cannot be in top position)*
8654-15S	4.5"H Drawer
8655-20S	6"H Drawer
8656-25S	7.5"H Drawer
8657-30S	9"H Drawer
8658-35S	10.5"H Drawer
8659-40S	12"H Drawer
8660-45S	13.5"H Drawer

*To minimize gap beneath beam as designated above. The drawer is the same 60"-wide drawer that is used in our modular cabinets. Only 400 lb. capacity is available.

3. Select divider sets for each drawer

that will help you maximize your storage space within each drawer. Divider sets are optional, and are not required to order a cabinet. All dividers are smooth office gray in color.

Divider kits - 60" wide

Divider Set	For 3" High Drawer	For 4 1/2" High Drawer	For 6" High and Up Drawer
Type C	4153C10	4154C15	4155C20
Type D	4153D10	4154D15	4155D20
Type E	4153E10	4154E15	4155E20
Type F	4153F10	4154F15	4155F20
Type H	4153H10	4154H15	4155H20

Partitions

Partition Height	To fit Drawer Height	To fit 27 3/4" Deep Drawers
2"	3"	8726
3"	4 1/2"	8727
4 1/2"	6" & up	8728

Full width partitions

Partition Height	To fit Drawer Height	To fit Cabinet Width	Part No.
2"	3"	60"	8736
3"	4 1/2"	60"	8737
4 1/2"	6" & up	60"	8738

Dividers

Width	For 3" High Drawers	For 4 1/2" High Drawers	For 6" High and Larger Drawers
3 3/32" (4 spaces)	8834	8844	8854
4 11/16" (6 spaces)	8835	8845	8855
6 9/32" (8 spaces)	8836	8846	8856
7 7/8" (10 spaces)	8837	8847	8857
9 7/16" (12 spaces)	8838	8848	8858
12 11/16" (16 spaces)	8839	8849	8859

Label Holder for individual dividers Part No. 6609

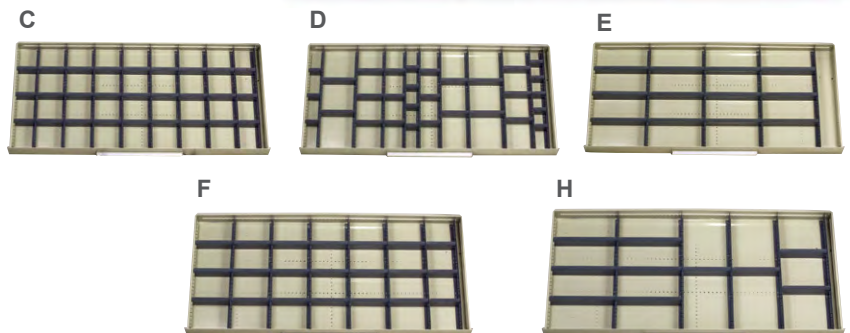

A standard color chart is available on page 150.

V-Grip™ Tire Rack

V-Grip Tire Racks provide a flexible and economical tire storage system. Tire Racks are available in various heights in either a stationary or mobile configuration. Support beams provide a rigid 3-point connection to V-Grip upright post and are adjustable on 1 1/2" centers to accommodate a variety of tire sizes.

Tire racks

- Racks assemble quickly and adjust with a minimum number of tools
- Beams adjust up or down on 1 1/2" centers
- Brackets furnished for back-to-back or against the wall use



Tire racks are adjustable for all passenger car sizes of tires and rims. If you require shelving to fit truck tires please contact Equipto Inside Sales.

Racks hold 7 to 10 tires Each level 15"D x 60"W

All equipment assembles as shown, with cross beams locking into uprights. Beams are adjustable on 1 1/2" centers. All tire racks are furnished with brackets which may be used to anchor to wall or back-to-back. Floor anchors are provided for all starter and add-on units.

Beam-to-Post Connection

Strong, V-Grip uprights with tapered slots accept 3 lugs on each beam end to lock post to beam firmly, without fasteners.



4 Tier (120" H)



3 Tier (84" H)



Mobile Tire Rack

18"D x 60"W x 67"H
2 tier with casters / Part No. 806-52MOB

806-52S Starter 806-52A Add-on 806-32S Starter 806-32A Add-on

Includes wall tie and floor anchor

Separator wall tie

This flange is to be used for bolting brackets back-to-back or for mounting to a wall (hardware for mounting to wall by others).



11561 - Single tie
11562 - Set of two (for back-to-back racks)

Floor anchor



Upright

Floor anchor
R.H & L.H.
7695L
7695R

A standard color chart is available on page 150.

Zip-In Shelving

Equipto's Zip-In shelving is the ideal solution when there is frequent change in the size of items being stored and the ability to easily change the vertical clear opening of each shelf location is a prerequisite. Zip-In shelves simply slide in and out of the unit without unloading or removing adjacent shelves. Back panel is white. End panels are the color of the unit.



Zip-In shelving units provide adjustability of shelves on 1 1/2" centers.



Zip-In shelves adjust easily by sliding shelves in and out of the system.



Sliding dividers attach easily without hardware or fasteners and provide infinite adjustability left to right.



Zip-In Shelving Preconfigured Units

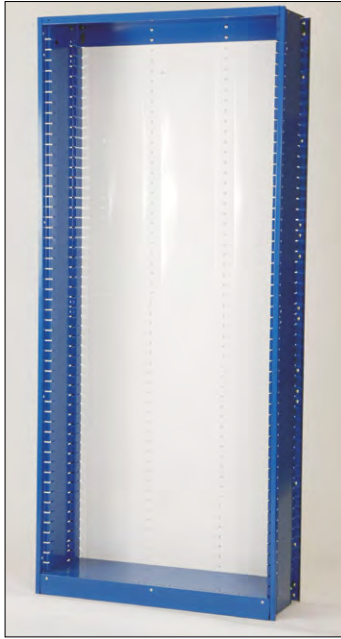

Part No. 3020



Part No. 3022



Part No. 3010



Part No. 3012
shown with 27 openings

Zip-In units

(All units are 84" high x 37¹/₈" wide x 12" deep)

Part No.	Description
3020	With back: Shell only - order parts from list
3022	With back; 9 openings, 9" high
3010	With back; 21 bins: 18 - 12" x 12"; 3-9" x 12"
3012	With back; up to 36 openings, 9" x 9"

Zip-In components

(All units are 84" high x 37¹/₈" wide x 12" deep)

Part No.	Description
6098	Shelf 36" wide
6098L*	Shelf 36" wide, with label holder
6099	Bracket to attach two units side by side
10047	Shelf front channel reinforcement
8145	Divider 3" high for opening 4 ¹ / ₂ " or higher
8146	Divider 4 ¹ / ₂ " high for opening 6" or higher
8147	Divider 6" high for opening 9" or higher
8505	Drawer 5 ⁵ / ₈ " x 3 ¹ / ₈ "
8720	Drawer straight divider – maximum of 11 dividers per shelf

*6098(L) will carry 242 lb. evenly distributed load

Supports to use when supporting deckover platforms over Zip-In Shelving

Part No.	Description
41327-01	Vertical support 87" high painted
41327-02	Corner support 87" high painted
41327-03	Vertical support 96" high painted
41327-04	Corner support 96" high painted



Equipto Label Holder

is a neat and easy way to identify records or supplies.

Part No. 6615

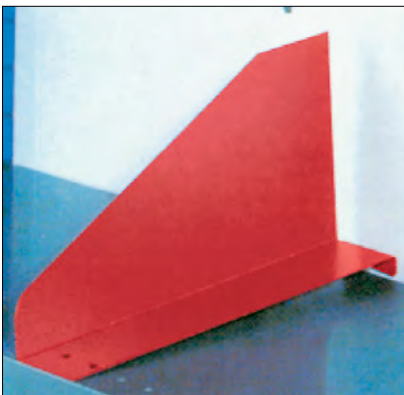

Sliding divider

Hooks into shelf holes and snap-locks into place on 1" centers without interfering with label holders.

*V-Grip only



Shelf drawer

6 across fills Zip-In Shelf. Order drawer divider separately. Part No. 8505

If adding drawers, 2 No. 9213 per shelf are also required.

Iron Grip® Shelving

The heavier the load the tighter the grip!

Equipto Iron Grip® features the strongest, most resourceful system.

- Quick shelf placement without tools; just a simple, solid steel stud at every shelf corner.
- Independent unit concept is engineered for strength, and is infinitely adjustable for custom fitting to your specific needs.
- Iron Grip shelving provides superior strength for heavy applications
- Add drawers, dividers, bin fronts, bases or doors for your specific applications
- The largest upright anywhere, with a heavy gauge stud in each shelf corner which locks a double thickness of metal together
- Stud grip increases as additional weight is added to shelf

Heights: Iron Grip shelving units come in 84" height, 38^{5/8"}, 43^{1/8"}, 60", 72", 96", 120" and 180" high units are also available. Any other heights by special order. Specify desired height; we'll provide a prompt quotation.

PLEASE NOTE: This shelving is not interchangeable with V-Grip.



Superior Iron Grip strength automatically provides crucial 4-point reinforcement to shelves.

The tapered stud engages a sloped, key-shaped hole in the upright for instant binding strength.

Built to last. Studs are plated; other parts have oven-baked enamel surfaces, and all formed from prime rolled steel.

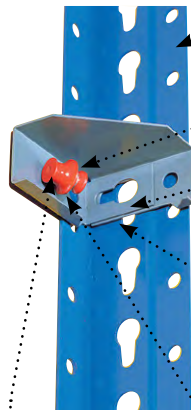

Part No. 10392

- 1" x 2^{3/8"} uprights (13 gauge), are the largest anywhere. Side embossing adds even more strength and rigidity to the unit
- Iron Grip shelf studs allow adjustment of shelves instantly on 1^{1/2"} centers
- Front and rear shelf flanges extend around the sides past keyhole. Steel stud binds both flanges to upright
- Dividers adjust on 1" centers with Speedy clips on 36" wide shelving (3" centers on 48" widths)

Shown in color for clarity, parts are actually zinc plated

Iron grip key

Fasten any two shelving units together quickly and easily. Easy-access keys remove just as simply, allowing rearrangement of any unit without disturbing adjacent units
U.S. patent No. 2,824,775

Use Iron Grip shelving in a variety of configurations: free-standing; side-by-side; back-to-back; or arranged in efficient work centers. Each shelf unit has four uprights.

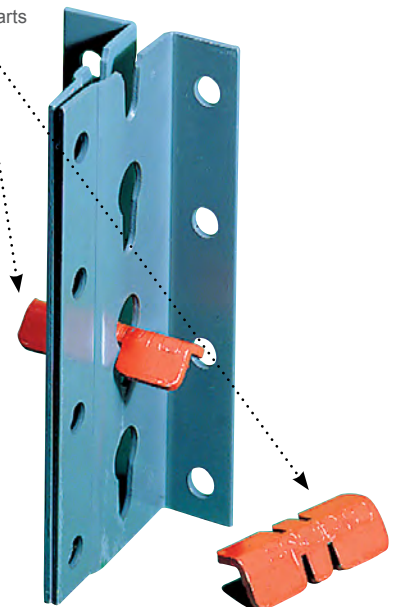

Part No. 10394

Durable 18-gauge shelves feature box-formed edges on all four sides. Adding 13-gauge, U-formed channels (3/8" x 1^{3/32"}) provides extra strength reinforcement on heavily loaded shelves. For heaviest use, also add end and center channels. Angles (1" x 1") made of 1/8" thick carbon steel provide optional reinforcement at the ends.

High visibility panels

Equipto furnishes high visibility white back and end panels on Iron Grip shelving units, regardless of the color of other. Standard color on Iron Grip shelving is office gray with white panels. Optional decorator colors will also be shipped with white panels unless you specify otherwise.

A standard color chart is available on page 150.



Iron Grip® Shelving

- Reinforced shelf capacities up to 2000 lbs. per shelf
- Non-reinforced shelf capacities of 700 lbs. per 36" W shelf
- Remarkable Iron Grip strength
- Modular system allows quick adjustment of individual shelves as well as units
- Largest, sturdiest upright anywhere
- As the shelves are loaded, the unit strength increases
- Reflective white back and end panels are standard, regardless of shelf color

Closed Shelving Units

Note: Starter unit has 2 closed ends; additional unit has 1 closed end. All units have 4 upright posts.

Depth	Starting or Additional Unit	6 Shelves Avg. 16 1/2" c.c.	10 Shelves Avg. 9" c.c.	Extra Shelf
12"	Starter	70-6KD	70-10KD	6091
12"	Add-on	71-6KD	71-10KD	6091
18"	Starter	72-6KD	72-10KD	6150
18"	Add-on	73-6KD	73-10KD	6150
24"	Starter	74-6KD	74-10KD	6185
24"	Add-on	75-6KD	75-10KD	6185
36"	Starter	76-6KD	76-10KD	6260
36"	Add-on	77-6KD	77-10KD	6260

To order set-up (extra charge), change "KD" suffix to "SU".

Open Shelving Units

Depth	6 Shelves Avg. 16 1/2" c.c.	10 Shelves Avg. 9" c.c.	Extra Shelf
12"	60-6KD	60-10KD	6091
18"	62-6KD	62-10KD	6150
24"	64-6KD	64-10KD	6185
36"	66-6KD	66-10KD	6260

Width: All units in table are 3' wide. To order 4' widths (in any depth except 36"), substitute "W" for "-" in catalog number. Example: 60-6 is 3' wide: 60W6 is 4' wide.

Height: All units in table are 7' high. Units available in all additional heights listed in "Uprights" section on Page 32.

To order set-up (extra charge), change "KD" suffix to "SU". When shipped assembled, nuts and bolts are used instead of shelf studs.



Closed back and end



Open shelf

Iron Grip® Shelving with Drawers

Preconfigured units

- New 200-lb. and 400-lb. drawer slides
- Units are supplied with white back and end panels
- Keep bulk and individual parts in the same unit for better inventory control
- Add lockable swinging doors for extra protection and security
- All drawers extend 100%
- All preassembled units are 36" wide and 84" high
- Combine shelving and drawers in one unit



S4203/S4210



S4204/S4211



S4205/S4212



S4206/S4213



S4207/S4214



S4208D

Unit Description	Part Numbers			
	18" Deep w/o Dividers	18" Deep w/ Dividers	24" Deep w/o Dividers	24" Deep w/ Dividers
12 drawers 3" high, 4 shelf openings 12" high	S4203N	S4203DN	S4210N	S4210DN
8 drawers 4 1/2" high, 4 shelf openings 12" high	S4204N	S4204DN	S4211N	S4211DN
6 drawers 6" high, 4 shelf openings 12" high	S4205N	S4205DN	S4212N	S4212DN
5 drawers 7 1/2" high, 4 shelf openings 12" high	S4206N	S4206DN	S4213N	S4213DN
3 drawers 12" high, 4 shelf openings 12" high	S4207N	S4207DN	S4214N	S4214DN
2 drawers 3" high, 2 drawers 4 1/2" high, 2 drawers 6" high, 1 drawer 7 1/2" high, 3 shelf openings 15" high	S4208N	S4208DN	S4215N	S4215DN

Doors for these units available on pages 16 and 32. Note: Above units feature Quiet-Ride™ 200 pound capacity drawers. **To order 400 lb capacity Heavy-Duty drawers, substitute "H" for "N" in Part No., e.g., S4215H instead of S4215N.**

Handles are furnished the same color as the drawer and all units have reflective white back and side panels.

A standard color chart is available on page 150.

Components



Equipto's commitment to quality control and fast turnaround service assures reliable assistance to our customers in replacing, adapting or expanding Iron Grip shelving systems. Our complete line of dependable parts is your guide to achieving complete flexibility in your space utilization system.

Sway braces (pair)

Description	Part No.
36" Back, 50 ¹ / ₈ " CC	6499
48" Back, 67 ³ / ₁₆ " CC	6431
12" End, 13 ⁵ / ₃₂ " CC	6480
18" End, 25 ³ / ₁₆ " CC	6481
24" End, 33 ⁹ / ₁₆ " CC	6482
36" End, 48 ¹ / ₈ " CC	6483
Upright to shelf corner, user must drill shelf	6495

End panels

Description	Part No.
12" x 43 ¹ / ₂ " high	7982
12" x 7'1 ¹ / ₂ " or less	7982-2
12" x 7'3" to 10'1 ¹ / ₂ "	7982-3
18" x 43 ¹ / ₂ " high	7983
18" x 7'1 ¹ / ₂ " or less	7983-2
18" x 7'3" to 10'1 ¹ / ₂ "	7983-3
24" x 43 ¹ / ₂ " high	7984
24" x 7'1 ¹ / ₂ " or less	7984-2
24" x 7'3" to 10'1 ¹ / ₂ "	7984-3
36" x 43 ¹ / ₂ " high	7991
36" x 7'1 ¹ / ₂ " or less	7991-2
36" x 7'3" to 10'1 ¹ / ₂ "	7991-3

Bases

Description	Part No.
Front, 1 ¹ / ₂ " x 36"	6923
Front, 3" x 36"	6924
Front, 3" x 48"	6930

Doors for shelving

Description	Part No.
36" wide x 7' H	18035
36" wide x 42" H	18043
36" wide x 34 ¹ / ₂ " H	18036

Swinging doors in free height attach quickly and securely.

Drawers

Modular drawers on page 15 available for Iron-Grip Shelving. Add "I" before N or H. Example: S8603IN.

Uprights

Description	Part No.
38 ⁵ / ₈ " Left hand	5598L
38 ⁵ / ₈ " Right hand	5599R
43 ¹ / ₂ " Left hand	5596L
43 ¹ / ₂ " Right hand	5597R
5' Left hand	5582L
5' Right hand	5583R
6' Left hand	5586L
6' Right hand	5587R
7' Left hand	5588L
7' Right hand	5589R
8' Left hand	5590L
8' Right hand	5591R
10' Left hand	5594L
10' Right hand	5595R
15' Left hand	5572L
15' Right hand	5573R
Splicer 8" long	5580

Bin fronts & labelholders

Description	Part No.
35 ³ / ₄ " x 1" Bin front	10506
35" x 3 ¹ / ₄ " Bin front	10507
46" x 3 ¹ / ₄ " Bin front	10508
34" x 1 ¹ / ₈ " Labelholder	6615
46" x 1 ¹ / ₈ " Labelholder	6613

Reinforcing channels & angles

Description	Part No.
End angle for 12" deep	9630
End angle for 18" deep	9631
End angle for 24" deep	9632
End angle for 36" deep	9633
36" Front or rear channel	10029
48" Front or rear angle	9636
36" Center channel	9629
48" Center channel	9637

Shelves (with studs)

Description	Part No.
12" x 36"	6091
18" x 36"	6150
24" x 36"	6185
36" x 36"	6260
12" x 48"	6111
18" x 48"	6165
24" x 48"	6198

Iron Grip® Shelving

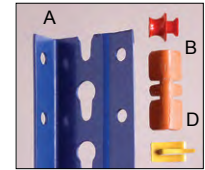
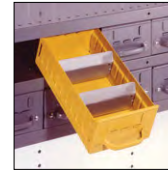

Drawers in a variety of widths and heights, with or without dividers, are available. (see drawer section.)

Iron Grip components: (A) Upright; (B) Shelf Stud; (D) Unit Key

Back panels

Description	Part No.
36" x 43 ¹ / ₂ " high	7506
36" x 7'1 ¹ / ₂ " or less	7506-2
36" x 7'3" to 10'1 ¹ / ₂ "	7506-3
48" x 43 ¹ / ₂ " high	7531
48" x 7'1 ¹ / ₂ " or less	7531-2
48" x 7'1 ¹ / ₂ " to 10'1 ¹ / ₂ "	7531-3

Dividers (standard color is smooth office gray)

Description	Part No.
2" x 12" deep	8049
4 ¹ / ₂ " x 12" deep	8018
6" x 12" deep	8019
7 ¹ / ₂ " x 12" deep	8020
9" x 12" deep	8021
10 ¹ / ₂ " x 12" deep	8022
12" x 12" deep	8023
13 ¹ / ₂ " x 12" deep	8024
15" x 12" deep	8025
16 ¹ / ₂ " x 12" deep	8026
4 ¹ / ₂ " x 18" deep	8090
6" x 18" deep	8094
7 ¹ / ₂ " x 18" deep	8095
9" x 18" deep	8096
10 ¹ / ₂ " x 18" deep	8097
12" x 18" deep	8098
13 ¹ / ₂ " x 18" deep	8099
16 ¹ / ₂ " x 18" deep	8091
18" x 18" deep	8092
6" x 24" deep	8119
7 ¹ / ₂ " x 24" deep	8120
18" x 18" deep	8092
9" x 24" deep	8121
10 ¹ / ₂ " x 24" deep	8122
12" x 24" deep	8123
13 ¹ / ₂ " x 24" deep	8124
15" x 24" deep	8125
16 ¹ / ₂ " x 24" deep	8126
10 ¹ / ₂ " x 36" deep	8133
12" x 36" deep	8134

Miscellaneous parts and hardware

Description	Part No.
Shelf stud	10392
Unit key	10394
Speedy clip	10226
Bolt & nut 3/16" x 3/8"	13000
Bolt & nut 3/16" x 1/4"	13001
Bolt & nut 1/4" x 1/2"	13002
Bolt & nut 1/4" x 1"	13003
Headed rod 3/16" x 85"	9720
Panel clip	10332
Corner brace	6420
Wide drawer filler strip	7702
Aisle safety rail 36"	10043G
Aisle safety rail 48"	10044G
Front seismic anchor	190330A
Common back anchor	190335A
Connect back to back	13163-4
	13060-4

A standard color chart is available on page 150.

Boltless "Rivet Rack" Storage Rack

Equipto Boltless Storage Rack is the economical alternative to standard steel shelving. Designed for hand loading and unloading only, it is ideal for automotive supplies, parts, warehouse materials, paint, batteries and just about anything else you need to store.

Preconfigured shelving units:

Frames only - wood or particle board shelves not included

Part No.	Description	Weight
RSR-693284	4 Shelves - 32"D X 69"W X 84"H	94 lbs
RSR-6932120	5 Shelves - 32"D X 69"W X 120"H	122 lbs
RSR-6932144	6 Shelves - 32"D X 69"W X 144"H	146 lbs



Design your own boltless storage rack shelving units with components

1. Upright angle - 1 11/16" x 2 1/4" 14 gauge

Part No.	Weight
RSR-UR-72	5.20
RSR-UR-84	6.10
RSR-UR-96	7.00
RSR-UR-120	8.70
RSR-UR-144	10.40



2. Front to back

RSR-FB-12	0.70
RSR-FB-18	1.20
RSR-FB-24	1.60
RSR-FB-30	2.00
RSR-FB-32	2.20
RSR-FB-36	2.50
RSR-FB-48	3.40



3. Left to right angle beams

RSR-LR-48	3.60
RSR-LR-69	5.10
RSR-LR-72	5.40
RSR-LR-96	8.40

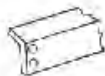

Left to right channel beam

BSR-CLR-72	7.70
BSR-CLR-96	10.40



4. Shelf tie support (48" - 72" width, 1 per shelf, 96" need 2 per shelf)

BSR-STC-24	2.10
BSR-STC-30	2.60
BSR-STC-32	2.70
BSR-STC-36	3.00
BSR-STC-48	4.00



Tie plate

BSR-TP	0.20
--------	------



5. Particle board shelves

Part No.	Description (D x W)	Weight
BSRPB-1236	12" x 36"	7.27 lbs.
BSRPB-1248	12" x 48"	9.69 lbs.
BSRPB-1269	12" x 69"	13.94 lbs.
BSRPB-1272	12" x 72"	14.54 lbs.
BSRPB-1296	12" x 96"	19.39 lbs.
BSRPB-1836	18" x 36"	10.91 lbs.
BSRPB-1848	18" x 48"	14.54 lbs.
BSRPB-1869	18" x 69"	20.90 lbs.
BSRPB-1872	18" x 72"	21.81 lbs.
BSRPB-1896	18" x 96"	29.08 lbs.
BSRPB-2436	24" x 36"	14.54 lbs.
BSRPB-2448	24" x 48"	19.39 lbs.
BSRPB-2469	24" x 69"	27.87 lbs.
BSRPB-2472	24" x 72"	29.08 lbs.
BSRPB-2496	24" x 96"	38.78 lbs.
BSRPB-3036	30" x 36"	18.18 lbs.
BSRPB-3048	30" x 48"	23.00 lbs.
BSRPB-3069	30" x 69"	34.87 lbs.
BSRPB-3072	30" x 72"	36.36 lbs.
BSRPB-3096	30" x 96"	48.48 lbs.
BSRPB-3236	32" x 36"	19.39 lbs.
BSRPB-3248	32" x 48"	25.85 lbs.
BSRPB-3269	32" x 69"	37.16 lbs.
BSRPB-3272	32" x 72"	38.78 lbs.
BSRPB-3296	32" x 96"	51.71 lbs.
BSRPB-3636	36" x 36"	20.00 lbs.
BSRPB-3648	36" x 48"	29.08 lbs.
BSRPB-3669	36" x 69"	41.81 lbs.
BSRPB-3672	36" x 72"	43.63 lbs.
BSRPB-3696	36" x 96"	58.17 lbs.
BSRPB-4848	48" x 48"	40.00 lbs.
BSRPB-4869	48" x 69"	55.75 lbs.
BSRPB-4872	48" x 72"	58.17 lbs.
BSRPB-4896	48" x 96"	77.56 lbs.

Specific to only Boltless Storage Rack shelving.

These do not fit other Equipto shelving with particle board shelves.

A standard color chart is available on page 150.

Bar Racks

Equipto Bar Racks are ideal for storing long and bulky parts as well as pipes. Each arm carries 325 lbs. Choose 3', 6' or 8' widths, to support parts as needed.

- Specialty bar racks
- Single or double face
- Two heights, three widths, two depths
- Use individually or in rows
- Shelves optionally available.
- Capacity 650 lbs. per level

Bar Racks are the effective answer to organizing steel — or any other items that don't need shelf support. Slotted angle, pipe, tubes, bars — Equipto Bar Racks hold them all. With no wasted space and absolutely simple access. Note: Be sure to order a rack end to finish each row.†



Shelves (12" x 36") fit between rack arms to hold long and short products in same unit.



Single-faced rack with end can be used free-standing to hold slotted angle, pipe, bars, etc.



Why try to maneuver those special items in and out of shelving, when they don't need to be there in the first place? Solid steel Equipto Bar Racks are specially designed for just those items. Single or double-face bar racks in a range of heights and widths can be used individually or in rows. You can even add a shelf here and there for items too short to reach between rack arms.

Accessories

Description	Part No.
Extra Arm, 12" deep; capacity 325 lbs. (order a pair to add a level)	1070
12" x 36" Extra shelf for bottom arms only	6052
12" x 36" Extra shelf for other arms	6053

Bar Racks - a complete rack includes one or more units and a rack end. (†)

Description	Height	Width	Depth	Part No
Double-face unit	7'	3'	34"	1060
Double-face unit	7'	6'	34"	1060-72
Double-face unit	7'	8'	34"	1060-96
†Double-face rack end	7'	2 ³ / ₈ "	34"	1061
Single-face unit	7'	3'	22 ¹ / ₈ "	1062
Single-face unit	7'	6'	22 ¹ / ₈ "	1062-72
Single-face unit	7'	8'	22 ¹ / ₈ "	1062-96
†Single-face rack end	7'	2 ³ / ₈ "	22 ¹ / ₈ "	1063
Double-face unit	4'	3'	34"	1064
Double-face unit	4'	6'	34"	1064-72
Double-face unit	4'	8'	34"	1064-96
†Double-face rack end	4'	2 ³ / ₈ "	34"	1065
Single-face unit	4'	3'	22 ¹ / ₈ "	1066
Single-face unit	4'	6'	22 ¹ / ₈ "	1066-72
Single-face unit	4'	8'	22 ¹ / ₈ "	1066-96
†Single-face rack end	4'	2 ³ / ₈ "	22 ¹ / ₈ "	1067

A standard color chart is available on page 150.

Heavy Duty Bar Racks

The innovative, space-saving answer to organization of a wide range of long items, with a capacity of up to 12,000 lbs. per unit! Choose single or double-faced designs in 18 different sizes for your best application. Available in three widths, three heights and two arm lengths - all adjustable, and designed for economical, common upright performance.

- Ideal for long, difficult-to-organize items
- Organizes and protects valuable bar stock, pipe, lumber, conduit, steel angle, tool steel and more
- High capacity and high strength
- Adjustable on 2" centers
- 18" arm holds 1,000 lbs, 30" arm holds 500 lbs.,
- each frame up to 12,000 lbs.



Single-faced Rack Add-on
1043-48
Rack End
1043



Double-faced Rack Add-on
1040-48
Rack End
1040

Note: 8' high units have 5 levels; 10' and 12' high units have 6 and 7 levels respectively.

For additional arms, order:

Extra 18" arm: 1046-18

Extra 30" arm: 1056-30

A complete rack includes one or more units and a rack end.

Heavy Duty Bar Racks, Add-ons and Rack Ends

Single-faced 18" Arms (Unit Depth 36")

Unit Height	Width of Unit Bays			Rack End
	48"	72"	99"	
8'-0"	1043-48	1043-72	1043-99	1043
10'-0"	1044-48	1044-72	1044-99	1044
12'-0"	1045-48	1045-72	1045-99	1045

Double-faced 18" Arms (Unit Depth 54")

Unit Height	Width of Unit Bays			Rack End
	48"	72"	99"	
8'-0"	1040-48	1040-72	1040-99	1040
10'-0"	1041-48	1041-72	1041-99	1041
12'-0"	1042-48	1042-72	1042-99	1042

Single-faced 30" Arms (Unit Depth 48")

Unit Height	Width of Unit Bays			Rack End
	48"	72"	99"	
8'-0"	1053-48	1053-72	1053-99	1053
10'-0"	1054-48	1054-72	1054-99	1054
12'-0"	1055-48	1055-72	1055-99	1055

Double-faced 30" Arms (Unit Depth 78")

Unit Height	Width of Unit Bays			Rack End
	48"	72"	99"	
8'-0"	1050-48	1050-72	1050-99	1050
10'-0"	1051-48	1051-72	1051-99	1051
12'-0"	1052-48	1052-72	1052-99	1052

Note: Be sure to order a rack end to finish each row.

Note: Limit 6 arms per upright. Capacity: 18" arm-1,000 lbs. each; 30" arm-500 lbs. each.



Hand loading and retrieval is fast with easy access from either side of rack.



Power trucks can load heavier items on rack with access from either side.

A standard color chart is available on page 150.

Reel Racks

Organize reels of cable and supplies, making them easy to retrieve. Equipto Reel Racks hold up to 2000 lbs. per level, and up to 12000 lbs. per rack. (Reel Rods not included.)

Racks hold small to large reels on both sides — safely. And you can move them easily by hand or fork lift truck.

- High capacity free standing A-frame racks
- 96"-120"-144" heights
- Rack is 26" deep at the base
- 12000 lb. capacity
- 3" x 3" vertical posts with mounting holes
- Adjustable cross beams on 2" centers with automatic safety locks
- Rack end required for each row of units



1072R04

1076E08
rack ends

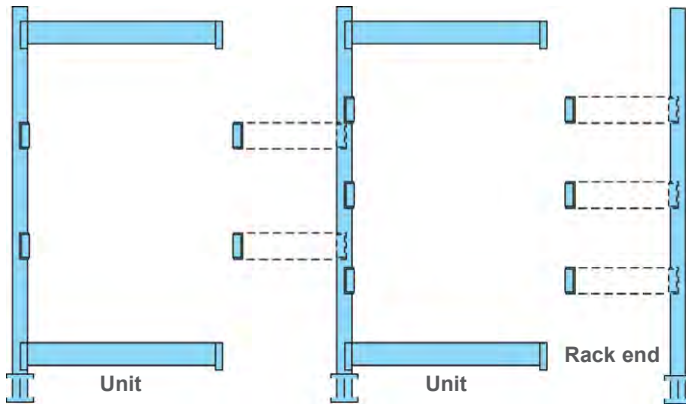

Each unit supplied with right-hand reel holders (as specified) that fasten to next unit or rack end.

	Width			No. of Reel Holders
	96"	120"	144"	
48"	1072R04	1072R14	1072R24	Two pair
72"	1072R06	1072R16	1072R26	Two pair
48"	1073R04	1073R14	1073R24	Three pair
72"	1073R06	1073R16	1073R26	Three pair
48"	1074R04	1074R14	1074R24	Four pair
72"	1074R06	1074R16	1074R26	Four pair
48"	1075R04	1075R14	1075R24	Five pair
72"	1075R06	1075R16	1075R26	Five pair
1076E08 Rack End, 96" high				
1076E10 Rack End, 120" high				
1076E12 Rack End, 144" high				

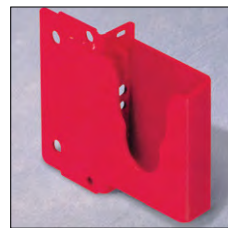

Extra reel holders

- Pairs only.
- Reel holders accommodate axles up to 2^{3/8}" O.D.

Shaft Size	Capacity	Part No. (pr.)
To 2 ^{3/8} " O.D.	2000 lbs.	78218RH

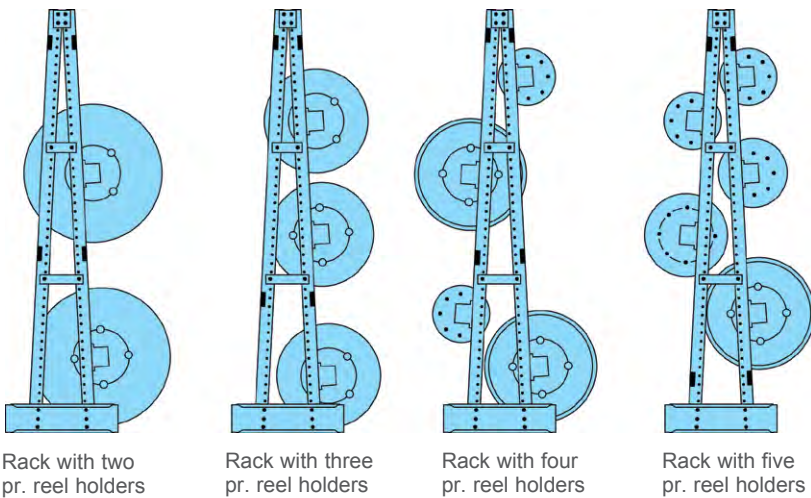

Rack with two pr. reel holders

Rack with three pr. reel holders

Rack with four pr. reel holders

Rack with five pr. reel holders

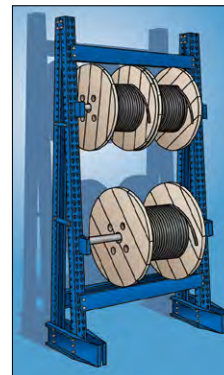

Pipe not included. Secure standard schedule 40 pipe (up to 2" nominal) from your local plumbing supply. Use 47" pipe length for 48" wide rack; 71" pipe for 72" wide rack. Reel holders are adjustable on 2" increments to hold multiple reels.

A standard color chart is available on page 150.

Wire Spool Management Units

Equipto provides storage for all types of parts. Keep grinding wheels, spools, and even auto body parts on these unique, heavy-duty racks.

NEW!

Portable Spool Rack

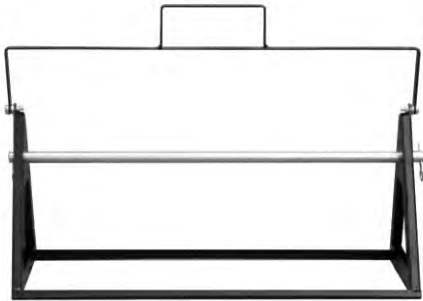

Description: Portable Spool Rack

Part No. PSR2408 — Holds 8" spool

Part No. PSR2411 — Holds 11" spool

Wire spool rack

- 7-shelf reel rack adjustable on 1 1/2" centers
- Organize and retrieve wire, cable, chain, hose, rope or tubing
- Holds reels up to 16" in diameter
- V-shaped shelves with center rod
- Fiberboard on shelves to deaden noise and prevent excessive uncoiling
- Spool rods are included

Wire Spool Racks

Description	Part No.
8"D x 36"W x 84"H	880-7
8"D x 48"W x 84"H	880-48
8"D x 60"W x 84"H	880-60

2 Floor Anchors included (#9709)



880-7

NEW!

Wire Rack Carts



4105-06W



4105-06WL

Wire Rack Carts

Part No.	Description
4105-06W	15" Wide Wire Cart with 6 Spool Holders
4105-06WL	15" Wide Wire Cart with 6 Spool Holders and Louvered Panel with bins
4110-06W	26" Wide Wire Cart with 6 Spool Holders
4110-06WL	26" Wide Wire Cart with 6 Spool Holders and Louvered Panel with bins
4140	Front Louver Panel 15"
4141	Front Louver Panel 26"
4142	Wire Spool Rod, 100lb capacity
050-0200Y	5" x 4-1/8" x 3" – 8lb capacity bin
050-0220Y	7-3/8" x 4-1/8" x 3" – 10lb capacity bin
050-0230Y	10-4/8" x 5-1/2" x 5" – 30lb capacity bin



NEW!

880-48



NEW!

880-60

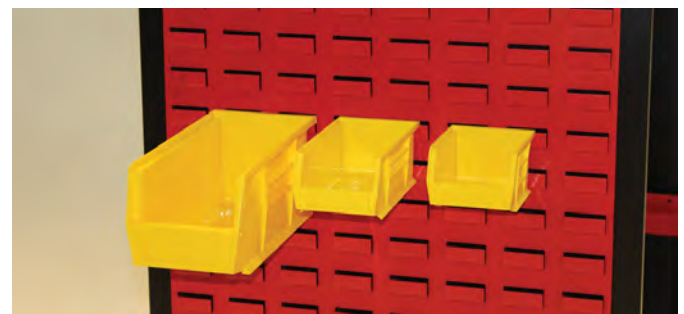

050-0230Y

050-0220Y

050-0200Y

A standard color chart is available on page 150.

Wire Shelving



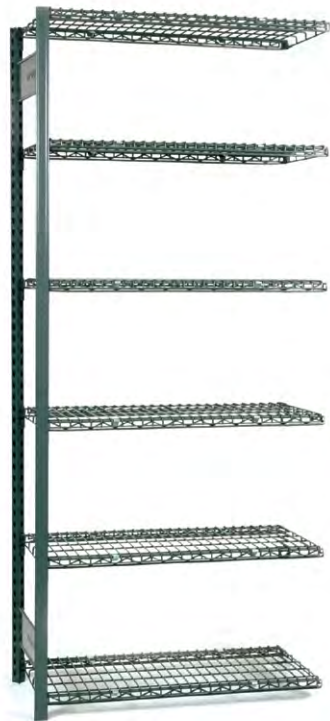

Add-on*



Starter

Standard Color - Mirror silver. For other colors refer to Equipto color chart on page 150. *Not shown to scale.

Extra wire shelves

Depth	3' wide	4' wide	6' wide
18"	6073	6074	6076
24"	6083	6084	6086

V-Grip™ Wire Shelving - 700 lb. capacity per shelf

Depth	Width	36"H with 2 shelves		48"H with 3 shelves		60"H with 4 shelves		72"H with 5 shelves		84"H with 6 shelves		96"H with 7 shelves		120"H with 9 shelves	
		Starter	Add-On	Starter	Add-On	Starter	Add-On	Starter	Add-On	Starter	Add-On	Starter	Add-On	Starter	Add-On

NEW!

BEST VALUE SHELVING SIZES

18"	36"	4533-02S	4533-02A	4534-03S	4534-03A	4535-04S	4535-04A	4536-05S	4536-05A	4537-06S	4537-06A	4538-07S	4538-07A	4530-09S	4530-09A
18"	48"	4543-02S	4543-02A	4544-03S	4544-03A	4545-04S	4545-04A	4546-05S	4546-05A	4547-06S	4547-06A	4548-07S	4548-07A	4540-09S	4540-09A
18"	72"	4563-02S	4563-02A	4564-03S	4564-03A	4565-04S	4565-04A	4566-05S	4566-05A	4567-06S	4567-06A	4568-07S	4568-07A	4560-09S	4560-09A
24"	36"	4633-02S	4633-02A	4634-03S	4634-03A	4635-04S	4635-04A	4636-05S	4636-05A	4637-06S	4637-06A	4638-07S	4638-07A	4630-09S	4630-09A
24"	48"	4643-02S	4643-02A	4644-03S	4644-03A	4645-04S	4645-04A	4646-05S	4646-05A	4647-06S	4647-06A	4648-07S	4648-07A	4640-09S	4640-09A
24"	72"	4663-02S	4663-02A	4664-03S	4664-03A	4665-04S	4665-04A	4666-05S	4666-05A	4667-06S	4667-06A	4668-07S	4668-07A	4660-09S	4660-09A

V-Grip™ Bulk Rack

V-Grip Bulk Rack is designed to accommodate longer spans and heavier loads than conventional shelving. Bulk Rack beams engage V-Grip upright posts providing a rigid connection. Bulk Rack levels are designed to carry load capacities from 1500 lbs. to 3000 lbs. per level, depending on beam span length and deck material used.

The units to the right are shown with optional wire decking for the top shelf and corrugated steel decking unit for the bottom shelf.



Three level bulk rack with decking

Depth	Height	48" Wide		72" Wide		96" Wide	
		Starter	Add-on	Starter	Add-on	Starter	Add-on
Standard duty (from 1100 lbs. to 1500 lbs. For specific capacities see chart on page 24)							
24"	60"	1005W42S	1005W42A	1005W62S	1005W62A	—	—
	72"	1006W42S	1006W42A	1006W62S	1006W62A	—	—
	84"	1007W42S	1007W42A	1007W62S	1007W62A	—	—
36"	60"	1005W43S	1005W43A	1005W63S	1005W63A	—	—
	72"	1006W43S	1006W43A	1006W63S	1006W63A	—	—
	84"	1007W43S	1007W43A	1007W63S	1007W63A	—	—
48"	60"	1005W44S	1005W44A	1005W64S	1005W64A	—	—
	72"	1006W44S	1006W44A	1006W64S	1006W64A	—	—
	84"	1007W44S	1007W44A	1007W64S	1007W64A	—	—
Medium duty (from 1500 lbs. to 2000 lbs. For specific capacities see chart on page 24)							
24"	60"	1015W42S	1015W42A	1015W62S	1015W62A	1015W82S	1015W82A
	72"	1016W42S	1016W42A	1016W62S	1016W62A	1016W82S	1016W82A
	84"	1017W42S	1017W42A	1017W62S	1017W62A	1017W82S	1017W82A
36"	60"	1015W43S	1015W43A	1015W63S	1015W63A	1015W83S	1015W83A
	72"	1016W43S	1016W43A	1016W63S	1016W63A	1016W83S	1016W83A
	84"	1017W43S	1017W43A	1017W63S	1017W63A	1017W83S	1017W83A
48"	60"	1015W44S	1015W44A	1015W64S	1015W64A	1015W84S	1015W84A
	72"	1016W44S	1016W44A	1016W64S	1016W64A	1016W84S	1016W84A
	84"	1017W44S	1017W44A	1017W64S	1017W64A	1017W84S	1017W84A
Heavy duty (over 2000 lbs. For specific capacities see chart on page 24)							
24"	60"	1025W42S	1025W42A	1025W62S	1025W62A	1025W82S	1025W82A
	72"	1026W42S	1026W42A	1026W62S	1026W62A	1026W82S	1026W82A
	84"	1027W42S	1027W42A	1027W62S	1027W62A	1027W82S	1027W82A
36"	60"	1025W43S	1025W43A	1025W63S	1025W63A	1025W83S	1025W83A
	72"	1026W43S	1026W43A	1026W63S	1026W63A	1026W83S	1026W83A
	84"	1027W43S	1027W43A	1027W63S	1027W63A	1027W83S	1027W83A
48"	60"	1025W44S	1025W44A	1025W64S	1025W64A	1025W84S	1025W84A
	72"	1026W44S	1026W44A	1026W64S	1026W64A	1026W84S	1026W84A
	84"	1027W44S	1027W44A	1027W64S	1027W64A	1027W84S	1027W84A

Four level bulk rack with wire decking

Depth	Height	48" Wide		72" Wide		96" Wide	
		Starter	Add-on	Starter	Add-on	Starter	Add-on
Standard duty (from 1100 lbs. to 1500 lbs. For specific capacities see chart on page 24)							
24"	96"	1008W42S	1008W42A	1008W62S	1008W62A	—	—
	120"	1010W42S	1010W42A	1010W62S	1010W62A	—	—
36"	96"	1008W43S	1008W43A	1008W63S	1008W63A	—	—
	120"	1010W43S	1010W43A	1010W63S	1010W63A	—	—
48"	96"	1008W44S	1008W44A	1008W64S	1008W64A	—	—
	120"	1010W44S	1010W44A	1010W64S	1010W64A	—	—
Medium duty (from 1500 lbs. to 2000 lbs. For specific capacities see chart on page 24)							
24"	96"	1018W42S	1018W42A	1018W62S	1018W62A	1018W82S	1018W82A
	120"	1020W42S	1020W42A	1020W62S	1020W62A	1020W82S	1020W82A
36"	96"	1018W43S	1018W43A	1018W63S	1018W63A	1018W83S	1018W83A
	120"	1020W43S	1020W43A	1020W63S	1020W63A	1020W83S	1020W83A
48"	96"	1018W44S	1018W44A	1018W64S	1018W64A	1018W84S	1018W84A
	120"	1020W44S	1020W44A	1020W64S	1020W64A	1020W84S	1020W84A
Heavy duty (over 2000 lbs. For specific capacities see chart on page 24)							
24"	96"	1028W42S	1028W42A	1028W62S	1028W62A	1028W82S	1028W82A
	120"	1030W42S	1030W42A	1030W62S	1030W62A	1030W82S	1030W82A
36"	96"	1028W43S	1028W43A	1028W63S	1028W63A	1028W83S	1028W83A
	120"	1030W43S	1030W43A	1030W63S	1030W63A	1030W83S	1030W83A
48"	96"	1028W44S	1028W44A	1028W64S	1028W64A	1028W84S	1028W84A
	120"	1030W44S	1030W44A	1030W64S	1030W64A	1030W84S	1030W84A

Five level bulk rack with wire decking

Depth	Height	48" Wide		72" wide		96" wide	
		Starter	Add-on	Starter	Add-on	Starter	Add-on
Standard duty (from 1100 lbs. to 1500 lbs. For specific capacities see chart on page 24)							
36"	180"	1012W43S	1012W43A	1012W63S	1012W63A	—	—
48"	180"	1012 W44S	1012W44A	1012W64S	1012W64A	—	—
Medium duty (from 1500 lbs. to 2000 lbs. For specific capacities see chart on page 24)							
36"	180"	1022W43S	1022W43A	1022W63S	1022W63A	1022W83S	1022W83A
48"	180"	1022W44S	1022W44A	1022W64S	1022W64A	1022W84S	1022W84A

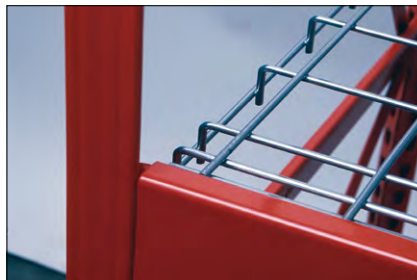

Drop In Wire decking

Capacity to 2667 lbs.

- Lets air, light and water pass through
- Offset between beam and wire shelving is .2625+/- or just over 1/4"

A standard color chart is available on page 150.

We have all of your favorite modular drawer cabinet sizes!

Modular Drawer Cabinets



Cabinet Height	22 1/2" Wide	30" Wide	36" Wide	45" Wide	60" Wide
29"	Preconfigured	Preconfigured	Customer Configured	Customer Configured	Customer Configured
33 1/2"	Preconfigured	Preconfigured	Customer Configured	Customer Configured	Customer Configured
38"	Customer Configured	Preconfigured	Customer Configured	Preconfigured	Preconfigured
44"	Preconfigured	Preconfigured	Preconfigured	Preconfigured	Preconfigured
59"	Preconfigured	Preconfigured	Preconfigured	Preconfigured	Preconfigured



Modular Drawer Cabinets

Organize everything from the smallest hardware and jewelry to large motors and sporting equipment. Every heavy-duty Equipto Modular Drawer Cabinet is engineered and manufactured with exacting precision for years of rugged use. The optional lock keeps your items secure. Utilize "more than one drawer accessibility"

Industrial, Military, Educational, Institutional, Automotive; no matter what your application, Equipto modular drawer cabinets save space, time and money!

22" to 60" wide cabinets

- Organized
- Fast retrieval
- Save time
- High density
- Rugged 12 gauge steel frames
- 200 and 400 lb. drawer capacity options
- Protect valuable tools
- Centralized control of equipment
- No assembly
- Custom units



Modular Drawer Cabinets

NEW!

- All cabinets include a lock

Dividers and Partitions

Each drawer is ribbed and slotted (3/4" centers) over the length and width of the drawer. Convenient numbered spacings simplify installation of partitions, and label holders permit quick identification of drawer contents. When fully extended, 100% of the drawer clears frame to allow unobstructed viewing of entire drawer contents. The interchangeability of drawer partitions and dividers permits changing drawer interiors easily - as you need to, and in unlimited patterns.



An integral fork lift base consisting of two 1^{3/4}" x 6" lifting channels arc-welded to the frame itself, permits inserting truck forks into wide channels for safe, easy transport of locked cabinets - even when fully loaded!

Anchor bolt

These bolting options allow you to anchor a modular drawer cabinet to either concrete or wood floors.



MDC-CFAK



MDC-WFAK

Part No.	Description
MDC-CFAK	concrete anchor bolts
MDC-WFAK	wood anchor bolts

Note: Newly designed 36^{7/8}" drawers with enhanced 200-lb. and 400-lb. drawer slides no longer include carriages.

22 1/2" Wide Modular Drawer Cabinets

NEW! All Cabinets Include a Lock

- 200 lbs. capacity per drawer (for 400 lb. capacity option contact Equipto)
- Smooth, quiet drawer operation
- One piece welded frames
- Fork lift channels on base of cabinet
- Each unit includes 2 lifting base covers (218909F)
- Electrostatic dissipative paint available
- 27 3/4" deep
- Drawer interior useable dimension is 18 3/4" W x 25 1/8" D



Model 4294

Modular Drawer Cabinets

22 1/2" Wide Modular Drawer Cabinets - Preconfigured Units

22 1/2" W x 27 3/4" D x 29" H



4260H
Drawer/Dividers included
(8) 3" h "H" Type
Order #4260 for unit
without divider kits.*



4261H
Drawer/Dividers included
(2) 3" h "H" Type
(4) 4.5" h "H" Type
Order #4261 for unit
without divider kits.*



4262H
Drawer/Dividers included
(2) 3" h "H" Type
(1) 6" h "H" Type
(1) 12" h "H" Type
Order #4262 for unit
without divider kits.*



4263H
Drawer/Dividers included
(1) 4.5" h "H" Type
(2) 6" h "H" Type
(1) 7.5" h "H" Type
Order #4263 for unit
without divider kits.*



4264H
Drawer/Dividers included
(4) 4.5" h "H" Type
(1) 6" h "H" Type
Order #4264 for unit
without divider kits.*

22 1/2" W x 27 3/4" D x 33 1/2" H



4270H
Drawer/Dividers included
(8) 3" h "H" Type
(1) 4.5" h "H" Type
Order #4270 for unit
without divider kits.*



4271H
Drawer/Dividers included
(2) 3" h "H" Type
(5) 4.5" h "H" Type
Order #4271 for unit
without divider kits.*



4272H
Drawer/Dividers included
(1) 3" h "H" Type
(1) 6" h "H" Type
(1) 7.5" h "H" Type
(1) 12" h "H" Type
Order #4272 for unit
without divider kits.*



4273H
Drawer/Dividers included
(1) 3" h "H" Type
(3) 4.5" h "H" Type
(2) 6" h "H" Type
Order #4273 for unit
without divider kits.*



4274H
Drawer/Dividers included
(5) 4.5" h "H" Type
(1) 6" h "H" Type
Order #4274 for unit
without divider kits.*

Drawer divider options

*This 22 1/2" wide pre-engineered modular drawer unit is also available with either all D, G, or H divider kits (see page 44). To specify, simply add the letter suffix after the first four digits of cabinet model number when ordering. Drop any following digits. Ex: 4420 becomes 4420D.

A standard color chart is available on page 150.

22¹/₂" W x 27³/₄" D x 44" H

Modular Drawer Cabinets



4280-01
Drawer/Dividers included
(6) 3" h "E" Type
(7) 3" h "G" Type
Order #4280 for unit
without divider kits.*



4281-01
Drawer/Dividers included
(1) 3" h "E" Type
(3) 4.5" h "E" Type
(5) 4.5" h "G" Type
Order #4281 for unit
without divider kits.*



4282-01
Drawer/Dividers included
(1) 3" h "E" Type
(3) 6" h "G" Type
(3) 6" h "H" Type
Order #4282 for unit
without divider kits.*



4283-01
Drawer/Dividers included
(3) 3" h "E" Type
(5) 4.5" h "G" Type
(1) 7.5" h "H" Type
Order #4283 for unit
without divider kits.*



4284-01
Drawer/Dividers included
(3) 3" h "E" Type
(1) 4.5" h "E" Type
(1) 6" h "G" Type
(1) 7.5" h "G" Type
(1) 12" h "K" Type
Order #4284 for unit
without divider kits.*



4285-01
Drawer/Dividers included
(1) 7.5" h "E" Type
(1) 9" h "G" Type
(1) 10.5" h "G" Type
(1) 12" h "K" Type
Order #4285 for unit
without divider kits.



4286-01
Drawer/Dividers included
(3) 4.5" h "E" Type
(3) 6" h "G" Type
(1) 7.5" h "H" Type
Order #4286 for unit
without divider kits.



4287-01
Drawer/Dividers included
(3) 4.5" h "E" Type
(3) 4.5" h "G" Type
(1) 12" h "K" Type
Order #4287 for unit
without divider kits.



4288-01
Drawer/Dividers included
(2) 9" h "G" Type
(2) 10.5" h "H" Type
Order #4288 for unit
without divider kits.

22¹/₂" W x 27³/₄" D x 59" H



4290-01
Drawer/Dividers included
(9) 3" h "E" Type
(9) 3" h "G" Type
Order #4290 for unit
without divider kits.*



4291-01
Drawer/Dividers included
(4) 4.5" h "E" Type
(4) 4.5" h "G" Type
(4) 4.5" h "H" Type
Order #4291 for unit
without divider kits.*



4292-01
Drawer/Dividers included
(3) 6" h "E" Type
(6) 6" h "G" Type
Order #4292 for unit
without divider kits.*



4293-01
Drawer/Dividers included
(5) 3" h "E" Type
(7) 4.5" h "G" Type
(1) 7.5" h "G" Type
Order #4293 for unit
without divider kits.*



4294-01
Drawer/Dividers included
(3) 3" h "E" Type
(3) 4.5" h "G" Type
(2) 6" h "G" Type
(1) 7.5" h "H" Type
(1) 12" h "K" Type
Order #4294 for unit
without divider kits.*

Drawer divider options

*This 22¹/₂" wide pre-engineered modular drawer unit is also available with either all D, G or H divider kits. To specify, simply add the letter suffix after the first four digits of cabinet model number when ordering. Drop any following digits. Ex: 4290-01 becomes 4290D.

22 1/2" Wide Modular Drawer Cabinets - Preconfigured Units

22 1/2" W x 27 3/4" D x 59" H

Modular Drawer Cabinets



4295-01
 Drawer/Dividers included
 (2) 7.5" h "E" Type
 (4) 7.5" h "G" Type
 (1) 9" h "H" Type
 Order #4295 for unit without divider kits*



4296-01
 Drawer/Dividers included
 (3) 4.5" h "E" Type
 (3) 6" h "H" Type
 (3) 7.5" h "H" Type
 Order #4296 for unit without divider kits*



4297-01
 Drawer/Dividers included
 (5) 6" h "G" Type
 (2) 7.5" h "H" Type
 (1) 9" h "H" Type
 Order #4297 for unit without divider kits*



4298-01
 Drawer/Dividers included
 (1) 4.5" h "E" Type
 (3) 6" h "G" Type
 (3) 7.5" h "E" Type
 (1) 9" h "E" Type
 Order #4298 for unit without divider kits*

Customizing a Modular Drawer Cabinet

22 1/2" Wide Modular Drawer Cabinets - Components

To customize an Equipto Modular Drawer Cabinet, first select a housing from the following options:

29" High, 33 1/2" High, 38" High, 44" High or 59" High

200 lbs. Housings (for 400 lbs. add an H to end of part #)

Part No.	Height	Points	Total Drawer Height Value
4269	29"	80	24"
4279	33 1/2"	95	28 1/2"
4228	38"	110	33"
4289	44"	130	39"
4299	59"	180	54"

All housings are 22 1/2" Wide & 27 3/4" Deep, 200 lb. Capacity

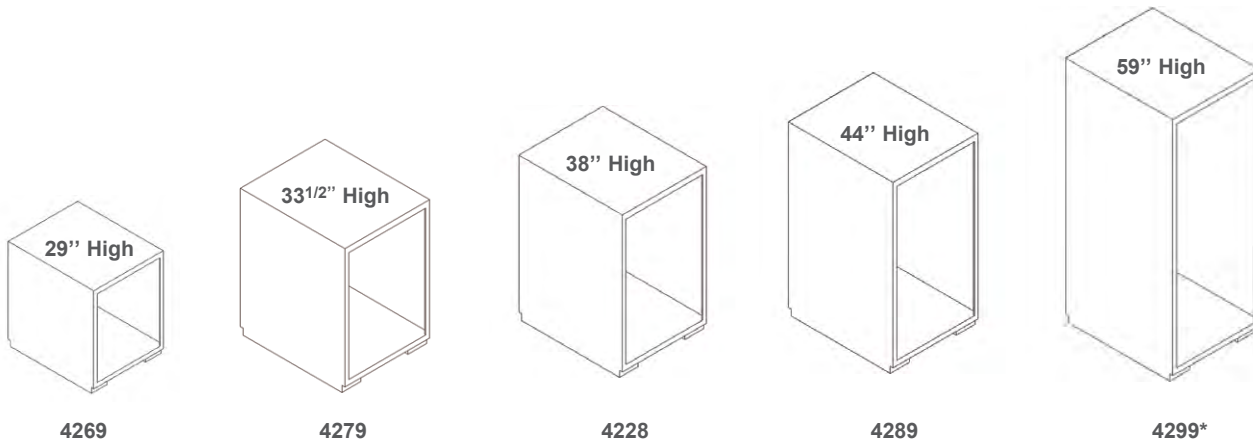

*Anchor kit recommended for 59" high units



Lock-out feature

RH Only (Add RH to Base Part Number – Ex: 8623-10 = 8623RH)

A standard color chart is available on page 150.

Select The Drawers You Want To Put In The Housing.

(Keeping in mind the simple point system, in which the summation of the individual drawer points must equal the total points for the cabinet housing.)

Interior useable dimensions on all drawers is 18³/₄" W x 25¹/₈" D

Drawers – 200 lbs. Capacity per drawer (for 400 lbs. drawers add an H before “-” in part #. Ex. 8623H-10, must be used with 400 lbs. housing)

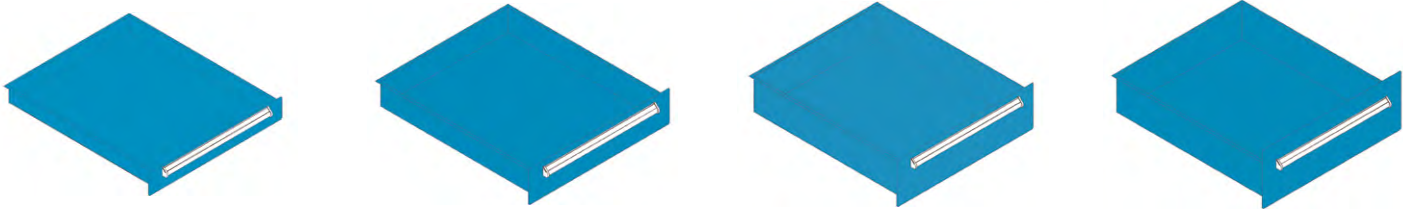

Part No.	Part No.	Part No.	Part No.
8623-10	8624-15	8625-20	8626-25
Height	Height	Height	Height
Front: 3"	Front: 4 ¹ / ₂ "	Front: 6"	Front: 7 ¹ / ₂ "
Body: 2 ¹ / ₈ "	Body: 3 ¹ / ₈ "	Body: 4 ⁵ / ₈ "	Body: 4 ⁵ / ₈ "
Useable: 2 ¹ / ₄ "	Useable: 3 ³ / ₄ "	Useable: 5 ¹ / ₄ "	Useable: 6 ³ / ₄ "
Points: 10	Points: 15	Points: 20	Points: 25

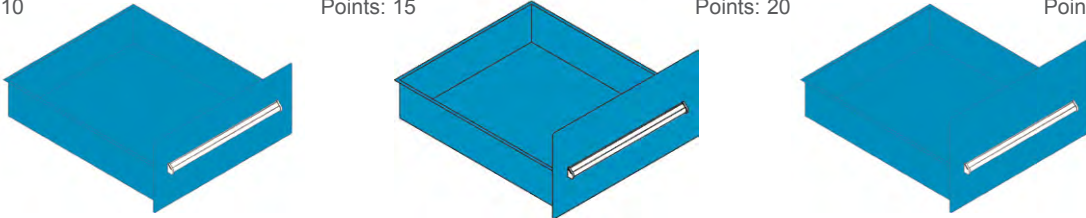

Part No.	Part No.	Part No.
8627-30	8628-35	8629-40
Height	Height	Height
Front: 9"	Front: 10 ¹ / ₂ "	Front: 12"
Body: 7 ⁵ / ₈ "	Body: 7 ⁵ / ₈ "	Body: 10 ⁵ / ₈ "
Useable: 8 ¹ / ₄ "	Useable: 9 ³ / ₄ "	Useable: 11 ¹ / ₄ "
Points: 30	Points: 35	Points: 40

Select divider sets for each drawer

that will help you maximize your storage space within each drawer.

Divider Sets are optional, and are not required to order a cabinet.

200 lbs. Divider kits - 22¹/₂" wide - all dividers are smooth office gray in color (for 400 lbs. add an H to end of part #. Only 3"-7¹/₂"H available)

Divider Set	For 3" High Drawer	For 4 ¹ / ₂ " High Drawer	For 6" and 7 ¹ / ₂ " High Drawers	For 9" and 10 ¹ / ₂ " High Drawers	For 12" High Drawer	No. of Compartments
Type D	4163D10	4164D15	4165D20	4167D30	4169D40	17
Type E	4163E10	4164E15	4165E20	4167E30	4169E40	16
Type G	4163G10	4164G15	4165G20	4167G30	4169G40	9
Type H	4163H10	4164H15	4165H20	4167H30	4169H40	6
Type K	4163K10	4164K15	4165K20	4167K30	4169K40	4

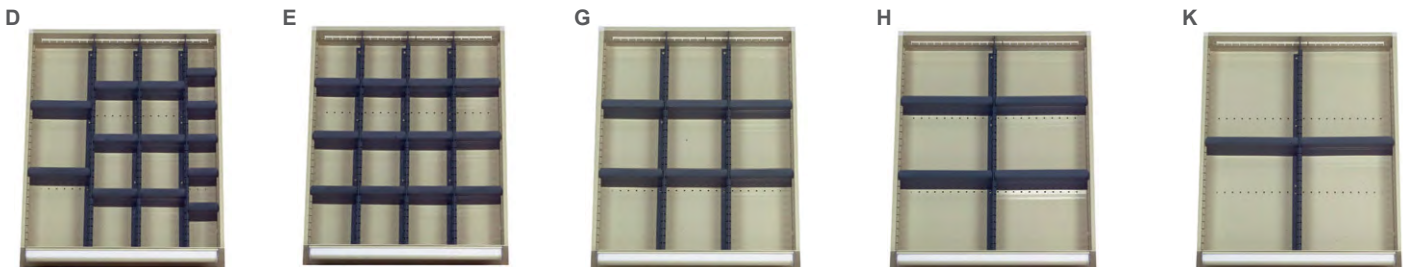

A standard color chart is available on page 150.

Modular Drawer Cabinets

30" Wide Modular Drawer Cabinets

NEW! All Cabinets Include a Lock

- 400 pound capacity drawers
- 100% drawer extension
- One piece welded frames
- Fork lift channels on base of cabinet
- Each unit includes 2 lift base covers
- 27³/₄" Deep
- Dividers are smooth office gray
- Drawer interior useable dimension is 25¹/₈" W x 25¹/₈" D



Model 4431

30" Wide Modular Drawer Cabinets - Preconfigured Units

30" W x 27³/₄" D x 29" H



4440H
Drawer/Dividers included
(8) 3" h "H" Type
Order #4440 for unit
without divider kits.*



4441H
Drawer/Dividers included
(2) 3" h "H" Type
(4) 4.5" h "H" Type
Order #4441 for unit
without divider kits.*



4442H
Drawer/Dividers included
(2) 3" h "H" Type
(1) 6" h "H" Type
(1) 12" h "H" Type
Order #4442 for unit
without divider kits.*



4443H
Drawer/Dividers included
(1) 4.5" h "H" Type
(2) 6" h "H" Type
(1) 7.5" h "H" Type
Order #4443 for unit
without divider kits.*



4444H
Drawer/Dividers included
(4) 4.5" h "H" Type
(1) 6" h "H" Type
Order #4444 for unit
without divider kits.*

30" W x 27³/₄" D x 33¹/₂" H



4430H
Drawer/Dividers included
(8) 3" h "H" Type
(1) 4.5" h "H" Type
Order #4430 for unit
without divider kits.*



4431H
Drawer/Dividers included
(2) 3" h "H" Type
(5) 4.5" h "H" Type
Order #4431 for unit
without divider kits.*



4432H
Drawer/Dividers included
(1) 3" h "H" Type
(1) 6" h "H" Type
(1) 7.5" h "H" Type
(1) 12" h "H" Type
Order #4432 for unit
without divider kits.*



4433H
Drawer/Dividers included
(1) 3" h "H" Type
(3) 4.5" h "H" Type
(2) 6" h "H" Type
Order #4433 for unit
without divider kits.*



4434H
Drawer/Dividers included
(5) 4.5" h "H" Type
(1) 6" h "H" Type
Order #4434 for unit
without divider kits.*

30" W x 27³/₄" D x 38" H



443038-512-01
Drawer/Dividers included
(5) 3" h "N" Type
(1) 4.5" h "R" Type
(1) 6.75" h "R" Type
(1) 6.75" h "E" Type
Order #443038-512MT
for unit without divider kits.



443038-412-01
Drawer/Dividers included
(4) 3" h "N" Type
(1) 4.5" h "R" Type
(1) 7.5" h "E" Type
(1) 9" h "F" Type
Order #443038-412MT
for unit without divider kits.



443038-042-01
Drawer/Dividers included
(4) 4.5" h "N" Type
(2) 7.5" h "E" Type
Order #443038-042MT
for unit without divider kits.



443038-005-01
Drawer/Dividers included
(1) 6" h "E" Type
(4) 6.75" h "E" Type
Order #443038-005MT
for unit without divider kits.

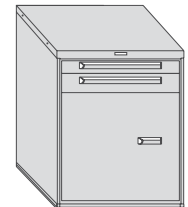

443038-11D-N
Drawer/Dividers included
(2) 4.5" h "N" Type
(1) 24" h Flush Cabinet Door
Order #443038-11DMT
for unit without divider kits.

Drawer divider options

*This 30" wide pre-engineered modular drawer unit is also available with either all A, B, C, D, E, F, G, H, K, L, M, N, P, R, or S divider kits (See page 49). To specify, simply add the letter suffix after the first four digits of cabinet model number when ordering. Drop any following digits. Ex: 4420-01 becomes 4420D.

A standard color chart is available on page 150.

Modular Drawer Cabinets

30" W x 27³/₄" D x 44" H



4410-01
 Drawer/Dividers included
 (3) 3" h "C" Type
 (6) 3" h "E" Type
 (4) 3" h "P" Type
 Order #4410 for unit
 without divider kits.*



4411-01
 Drawer/Dividers included
 (1) 3" h "C" Type
 (3) 4.5" h "E" Type
 (2) 4.5" h "G" Type
 (3) 4.5" h "P" Type
 Order #4411 for unit
 without divider kits.*



4412-01
 Drawer/Dividers included
 (1) 3" h "E" Type
 (3) 6" h "R" Type
 (3) 6" h "S" Type
 Order #4412 for unit
 without divider kits.*



4413-01
 Drawer/Dividers included
 (1) 3" h "B" Type
 (2) 3" h "E" Type
 (3) 4.5" h "F" Type
 (2) 4.5" h "P" Type
 (1) 7.5" h "G" Type
 Order #4413 for unit
 without divider kits.*



4414-01
 Drawer/Dividers included
 (3) 3" h "C" Type
 (1) 4.5" h "E" Type
 (1) 6" h "F" Type
 (1) 7.5" h "S" Type
 (1) 12" h "L" Type
 Order #4414 for unit
 without divider kits.*

Modular Drawer Cabinets



4415-01
 Drawer/Dividers included
 (1) 7.5" h "F" Type
 (1) 9" h "G" Type
 (1) 10.5" h "G" Type
 (1) 12" h "H" Type
 Order #4415 for unit
 without divider kits.*



4416-01
 Drawer/Dividers included
 (3) 4.5" h "P" Type
 (3) 6" h "G" Type
 (1) 7.5" h "S" Type
 Order #4416 for unit
 without divider kits.*



4417-01
 Drawer/Dividers included
 (3) 4.5" h "E" Type
 (3) 4.5" h "F" Type
 (1) 12" h "K" Type
 Order #4417 for unit
 without divider kits.*



4418-01
 Drawer/Dividers included
 (2) 9" h "S" Type
 (2) 10.5" h "H" Type
 Order #4418 for unit
 without divider kits.*

30" W x 27³/₄" D x 59" H



4420-01
 Drawer/Dividers included
 (3) 3" h "C" Type
 (5) 3" h "E" Type
 (5) 3" h "F" Type
 (5) 3" h "N" Type
 Order #4420 for unit
 without divider kits.*



4421-01
 Drawer/Dividers included
 (4) 4.5" h "E" Type
 (4) 4.5" h "F" Type
 (4) 4.5" h "G" Type
 Order #4421 for unit
 without divider kits.*



4422-01
 Drawer/Dividers included
 (9) 6" h "G" Type
 Order #4422 for unit
 without divider kits.*



4423-01
 Drawer/Dividers included
 (2) 3" h "C" Type
 (3) 3" h "N" Type
 (3) 4.5" h "E" Type
 (4) 4.5" h "F" Type
 (1) 7.5" h "G" Type
 Order #4423 for unit
 without divider kits.*



4424-01
 Drawer/Dividers included
 (3) 3" h "C" Type
 (3) 4.5" h "E" Type
 (2) 6" h "G" Type
 (1) 7.5" h "S" Type
 (1) 12" h "L" Type
 Order #4424 for unit
 without divider kits.*

Drawer divider options

*This 30" wide pre-engineered modular drawer unit is also available with either all A, B, C, D, E, F, G, H, K, L, M, N, P, R, or S divider kits (See page 49). To specify, simply add the letter suffix after the first four digits of cabinet model number when ordering. Drop any following digits. Ex: 4420-01 becomes 4420D.

A standard color chart is available on page 150.

30" Wide Modular Drawer Cabinets - Preconfigured Units

30" W x 27³/₄" D x 59" H (400 lb. Capacity per drawer)



4425-01
 Drawer/Dividers included
 (4) 7.5" h "F" Type
 (2) 7.5" h "P" Type
 (1) 9" h "S" Type
 Order #4425 for unit
 without divider kits.



4426-01
 Drawer/Dividers included
 (1) 4.5" h "E" Type
 (2) 4.5" h "F" Type
 (3) 6" h "F" Type
 (2) 7.5" h "G" Type
 (1) 7.5" h "H" Type
 Order #4426 for unit
 without divider kits.



4427-01
 Drawer/Dividers included
 (3) 6" h "F" Type
 (2) 7.5" h "S" Type
 (1) 9" h "H" Type
 Order #4427 for unit
 without divider kits.



4428-01
 Drawer/Dividers included
 (1) 4.5" h "E" Type
 (3) 6" h "R" Type
 (3) 7.5" h "G" Type
 (1) 9" h "S" Type
 Order #4428 for unit
 without divider kits.

Modular Drawer Cabinets

Customizing a Modular Drawer Cabinet

30" Wide Modular Drawer Cabinets - Components

To customize an Equipto Modular Drawer Cabinet, first select a housing from the following options:

29" High, 33¹/₂" High, 38" High, 44" High or 59" High

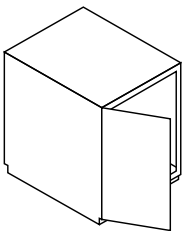

Cabinet w/ Flipper Door (like TBU door)

29"H (1) 010105 & (1) 010088K
 19-3/4"H (1) 010106 & (1) 010111K

Housings

Part No.	Height	Points	Total Drawer Height Value
4439	29"	80	24"
4429	33 ¹ / ₂ "	95	28 ¹ / ₂ "
4238	38"	110	33"
4409	44"	130	39"
4419	59"	180	54"

All housings are 30" W & 27³/₄" D



4439



4429

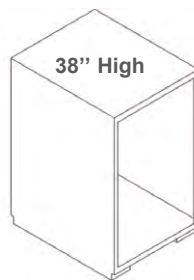

4238



4409

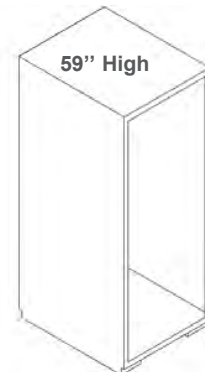

4419

(4419PTF has holes punched in top to stack a smaller cabinet. Use stacking hardware 7751-4.)



Lock-in Lock-out feature

RH and LH (Add RH or LH to Base Part Number – Ex: 8623-10 = 8623RH)

A standard color chart is available on page 150.

Select The Drawers You Want To Put In The Housing.

(Keeping in mind the simple point system, in which the summation of the individual drawer points must equal the total points for the cabinet housing.)

Drawer interior useable dimension is 25^{1/8"} W x 25^{1/8"} D

Drawers (400 lbs. Capacity per drawer)

Modular Drawer Cabinets



Part No.	Part No.	Part No.	Part No.
8633-10	8633T-12.5	8634-15	8634T-17.5
Height	Height	Height	Height
Front: 3"	Front: 3 ^{3/4"}	Front: 4 ^{1/2"}	Front: 5 ^{1/4"}
Body: 2 ^{1/8"}	Body: 2 ^{1/8"}	Body: 3 ^{1/8"}	Body: 3 ^{1/8"}
Useable: 2 ^{1/4"}	Useable: 3"	Useable: 3 ^{3/4"}	Useable: 4 ^{1/2"}
Points: 10	Points: 12.5	Points: 15	Points: 17.5



Part No.	Part No.	Part No.	Part No.
8635-20	8635T-22.5	8636-25	8636T-27.5
Height	Height	Height	Height
Front: 6"	Front: 6 ^{3/4"}	Front: 7 ^{1/2"}	Front: 8 ^{1/4"}
Body: 4 ^{5/8"}	Body: 4 ^{5/8"}	Body: 4 ^{5/8"}	Body: 4 ^{5/8"}
Useable: 5 ^{1/4"}	Useable: 6"	Useable: 6 ^{3/4"}	Useable: 7 ^{1/2"}
Points: 20	Points: 22.5	Points: 25	Points: 27.5



Part No.	Part No.	Part No.	Part No.
8637-30	8637T-32.5	8638-35	8638T-37.5
Height	Height	Height	Height
Front: 9"	Front: 9 ^{3/4"}	Front: 10 ^{1/2"}	Front: 11 ^{1/4"}
Body: 4 ^{5/8"}	Body: 4 ^{5/8"}	Body: 4 ^{5/8"}	Body: 4 ^{5/8"}
Useable: 8 ^{1/4"}	Useable: 9"	Useable: 9 ^{3/4"}	Useable: 10 ^{1/2"}
Points: 30	Points: 32.5	Points: 35	Points: 37.5

A standard color chart is available on page 150.

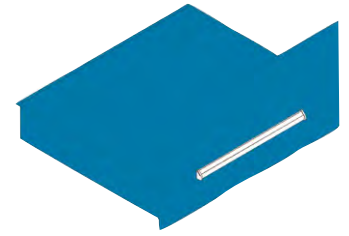
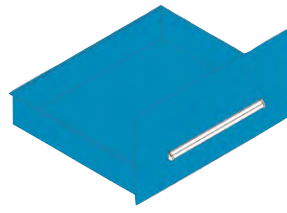
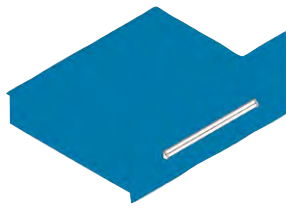
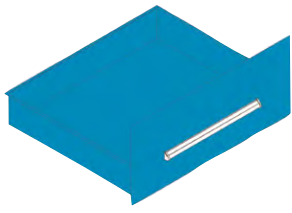

Part No.	Part No.	Part No.	Part No.
8639-40*	8639T-42.5	8640-45	8640T-47.5*
Height	Height	Height	Height
Front: 12"	Front: 12 ³ / ₄ "	Front: 13 ¹ / ₂ "	Front: 14 ¹ / ₄ "
Body: 4 ⁵ / ₈ "	Body: 4 ⁵ / ₈ "	Body: 4 ⁵ / ₈ "	Body: 4 ⁵ / ₈ "
Useable: 11 ¹ / ₄ "	Useable: 12"	Useable: 12 ³ / ₄ "	Useable: 13 ¹ / ₂ "
Points: 40	Points: 42.5	Points: 45	Points: 47.5

*Replace "-" with "HF" to get hanging file brackets

Select divider sets for each drawer

that will help you maximize your storage space within each drawer. Divider Sets are optional, and are not required to order a cabinet. Dividers are smooth office gray in color.

Divider kits - 30" wide

Divider Set	For 3" High Drawer	For 4 ¹ / ₂ " High Drawer	For 6" High and Up Drawer
Type A	4133A10	4134A15	4135A20
Type B	4133B10	4134B15	4135B20
Type C	4133C10	4134C15	4135C20
Type D	4133D10	4134D15	4135D20
Type E	4133E10	4134E15	4135E20
Type F	4133F10	4134F15	4135F20
Type G	4133G10	4134G15	4135G20
Type H	4133H10	4134H15	4135H20
Type K	4133K10	4134K15	4135K20
Type L	4133L10	4134L15	4135L20
Type M	4133M10	4134M15	4135M20
Type N	4133N10	4134N15	4135N20
Type P	4133P10	4134P15	4135P20
Type R	4133R10	4134R15	4135R20
Type S	4133S10	4134S15	4135S20

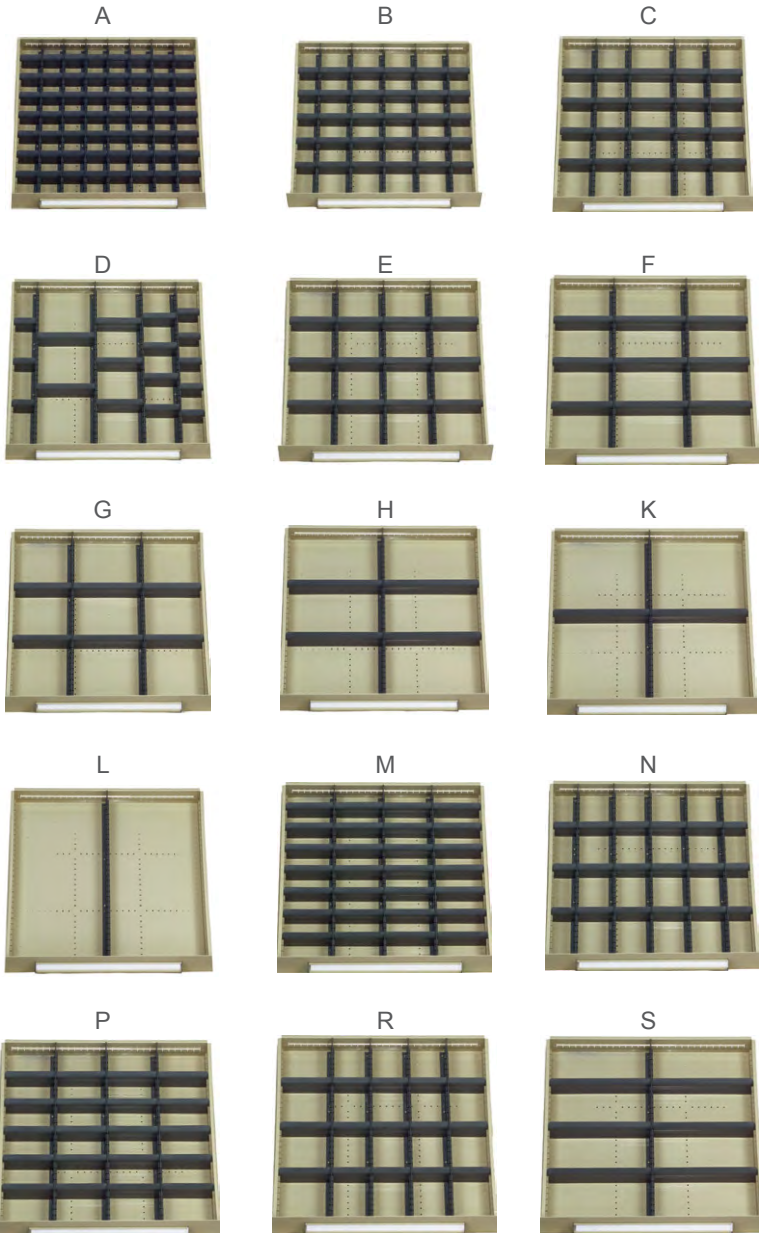

A standard color chart is available on page 150.

36⁷/₈" Wide Modular Drawer Cabinets

NEW! All Cabinets Include a Lock

- Use these modular drawer cabinets to organize more of your items in less floor space.
- High quality welded steel construction
- Precision engineered
- Each unit comes with one lift base front cover (#6839)
- 100% drawer extension
- Saves time
- Choose from 200 or 400 lb. Drawers
- Drawer interior dimensions: 19" – 31⁷/₁₆"W x 16³/₈"D
25" – 31⁷/₁₆"W x 22"D

For back lift base cover order (1) 6849 & (3) 13126

To order Heavy Duty 400 pound capacity drawers, replace "N" with "H" in catalog number.



Modular Drawer Cabinets

36⁷/₈" Wide Modular Drawer Cabinets - Preconfigured Units

36⁷/₈" W x 19 or 25" D x 44" H



S4330D18N (19"D)
S4330D24N (25"D)
Drawer/Dividers included (13) 3"h "D" Type
Order #S4330-24N or S4330-18N for unit without divider kits*



S4331D18N (19"D)
S4331D24N (25"D)
Drawer/Dividers included (1) 3"h "D" Type (8) 4.5"h "D" Type
Order #S4331-24N or S4331-18N for unit without divider kits*



S4332D18N (19"D)
S4332D24N (25"D)
Drawer/Dividers included (1) 3"h "D" Type (6) 6"h "D" Type
Order #S4332-24N or S4332-18N for unit without divider kits*



S4333D18N (19"D)
S4333D24N (25"D)
Drawer/Dividers included (3) 3"h "D" Type (6) 4.5"h "D" Type (1) 7.5"h "D" Type
Order #S4333-24N or S4333-18N for unit without divider kits*



S4334D18N (19"D)
S4334D24N (25"D)
Drawer/Dividers included (3) 3"h "D" Type (1) 4.5"h "D" Type (1) 6"h "D" Type (1) 7.5"h "D" Type (1) 12"h "D" Type
Order #S4334-24N or S4334-18N for unit without divider kits*

36⁷/₈" W x 19 or 25" D x 59" H



S4340D18N (19"D)
S4340D24N (25"D)
Drawer/Dividers included (18) 3"h "D" Type
Order #S4340-24N or S4340-18N for unit without divider kits*



S4341D18N (19"D)
S4341D24N (25"D)
Drawer/Dividers included (12) 4.5"h "D" Type
Order #S4341-24N or S4341-18N for unit without divider kits*



S4342D18N (19"D)
S4342D24N (25"D)
Drawer/Dividers included (9) 6"h "D" Type
Order #S4342-24N or S4342-18N for unit without divider kits*



S4343D18N (19"D)
S4343D24N (25"D)
Drawer/Dividers included (5) 3"h "D" Type (7) 4.5"h "D" Type (1) 7.5"h "D" Type
Order #S4343-24N or S4343-18N for unit without divider kits*



S4344D18N (19"D)
S4344D24N (25"D)
Drawer/Dividers included (3) 3"h "D" Type (3) 4.5"h "D" Type (2) 6"h "D" Type (1) 7.5"h "D" Type (1) 12"h "D" Type
Order #S4344-24N or S4344-18N for unit without divider kits*

Drawer divider options

*36⁷/₈" wide pre-engineered modular drawer units are also available with either all D, E, F or H divider kits.

To order, change "D" in part number to desired divider kit letter. ****Above units feature Quiet Ride™ 200 pound capacity drawers.**

To order Heavy Duty 400 pound capacity drawers, replace "N" with "H" in catalog number.

A standard color chart is available on page 150.

Customizing a Modular Drawer Cabinet

367/8" W x 19" or 25" D Modular Drawer Cabinets - Components

Modular Drawer Cabinets



4381-18

Jumbo Drawer Units

4381-18: 19Dx44H w/ 5 levels – (3) 8568 shelf drawers each level
4382-18: 19Dx59H w/ 7 levels – (3) 8568 shelf drawers each level
4362-18: 19Dx59H w/ 12 levels – (3) 8566 shelf drawers each level
4366-12: 12Dx59H w/ 12 levels – (6) 8550 shelf drawers each level
 *Each drawer comes with 2 dividers

Housings 19" Deep

Part No.	Height	Points	Total Drawer Height Value
4309-18	29"	80	24"
4319-18	33 1/2"	95	28 1/2"
4359-18	38"	110	33"
4329-18	44"	130	39"
4339-18	59"	180	54"

Useable drawer space is 317/16" W x 163/8" D

Housings 25" Deep

Part No.	Height	Points	Total Drawer Height Value
4309-24	29"	80	24"
4319-24	33 1/2"	95	28 1/2"
4359-24	38"	110	33"
4329-24	44"	130	39"
4339-24	59"	180	54"

Useable drawer space is 317/16" W x 22" D

All housings are 367/8" Wide & 19 or 25" Deep

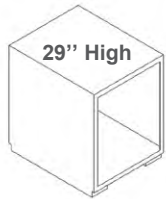

4309-18/4309-24

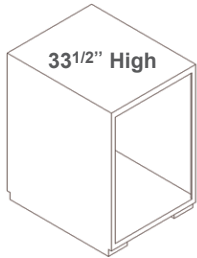

4319-18/4319-24

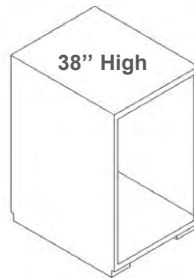

4359-18/4359-24



4329-18/4329-24

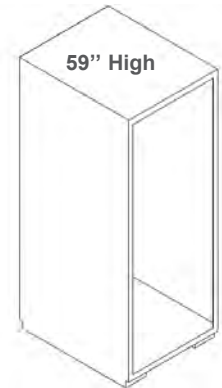

4339-18/4339-24



Lock-in Lock-out feature – call Equipto Customer Service

File Cabinets

- S4325-18F:** 19Dx29H w/ 2-12"H folder drawers
- S4339-18F:** 19Dx41H w/ 3-12"H folder drawers
- S4335-18F:** 19Dx44H w/ 3-12"H folder drawers & 1-3"H drawer
- S4345-18F:** 19Dx59H w/ 4-12"H folder drawers & 1-6"H drawer

Select The Drawers You Want To Put In The Housing.

(Keeping in mind the simple point system, in which the summation of the individual drawer points must equal the total points for the cabinet housing.)

Drawers (400 lbs. Capacity per drawer)

To order 200 pound capacity drawers, replace "H" with an "N" in catalog number.



Part No. 19"D	Part No. 25"D	Part No. 19"D	Part No. 25"D	Part No. 19"D	Part No. 25"D
S8603CH	S8610CH	S8604CH	S8611CH	S8605CH	S8612CH
Height	Height	Height	Height	Height	Height
Front: 3"	Front: 3"	Front: 4 1/2"	Front: 4 1/2"	Front: 6"	Front: 6"
Body: 2 1/8"	Body: 2 1/8"	Body: 3 1/8"	Body: 3 1/8"	Body: 4 5/8"	Body: 4 5/8"
Useable: 2 1/4"	Useable: 2 1/4"	Useable: 3 3/4"	Useable: 3 3/4"	Useable: 5 1/4"	Useable: 5 1/4"
Points: 10	Points: 10	Points: 15	Points: 15	Points: 20	Points: 20

A standard color chart is available on page 150.

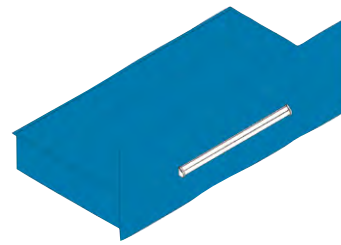

Part No. 19"D	Part No. 25"D	Part No. 19"D	Part No. 25"D	Part No. 19"D	Part No. 25"D
S8606CH	S8613CH	S8601CH	S8615CH	S8602CH	S8616CH
Height	Height	Height	Height	Height	Height
Front: 7 ¹ / ₂ "	Front: 7 ¹ / ₂ "	Front: 9"	Front: 9"	Front: 10 ¹ / ₂ "	Front: 10 ¹ / ₂ "
Body: 4 ⁵ / ₈ "	Body: 4 ⁵ / ₈ "	Body: 7 ⁵ / ₈ "	Body: 7 ⁵ / ₈ "	Body: 7 ⁵ / ₈ "	Body: 7 ⁵ / ₈ "
Useable: 6 ³ / ₄ "	Useable: 6 ³ / ₄ "	Useable: 8 ¹ / ₄ "	Useable: 8 ¹ / ₄ "	Useable: 9 ³ / ₄ "	Useable: 9 ³ / ₄ "
Points: 25	Points: 25	Points: 30	Points: 30	Points: 35	Points: 35

Modular Drawer Cabinets

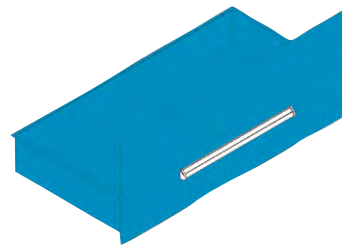

Part No. 19"D	Part No. 25"D	Part No. 19"D	Part No. 25"D
S8607CH*	S8614CH	S8608CH	S8617CH
Height	Height	Height	Height
Front: 12"	Front: 12"	Front: 13 ¹ / ₂ "	Front: 13 ¹ / ₂ "
Body: 10 ⁵ / ₈ "	Body: 10 ⁵ / ₈ "	Body: 10 ⁵ / ₈ "	Body: 10 ⁵ / ₈ "
Useable: 11 ¹ / ₄ "	Useable: 11 ¹ / ₄ "	Useable: 12 ³ / ₄ "	Useable: 12 ³ / ₄ "
Points: 40	Points: 40	Points: 45	Points: 45

*Order S8607FC for drawer including 8860 file hanger

Select divider sets for each drawer

that will help you maximize your storage space within each drawer.

Divider Sets are optional, and are not required to order a cabinet.

All dividers are smooth office gray in color.

Divider kits - 19" deep, 36" wide

Divider Set	For 3" High Drawer	For 4 ¹ / ₂ " High Drawer	For 6" High and Up Drawer
Type D	4173D10	4174D15	4175D20
Type F	4173F10	4174F15	4175F20
Type H	4173H10	4174H15	4175H20

Divider kits - 25" deep, 36" wide

Divider Set	For 3" High Drawer	For 4 ¹ / ₂ " High Drawer	For 6" High and Up Drawer
Type D	4183D10	4184D15	4185D20
Type F	4183F10	4184F15	4185F20
Type H	4183H10	4184H15	4185H20

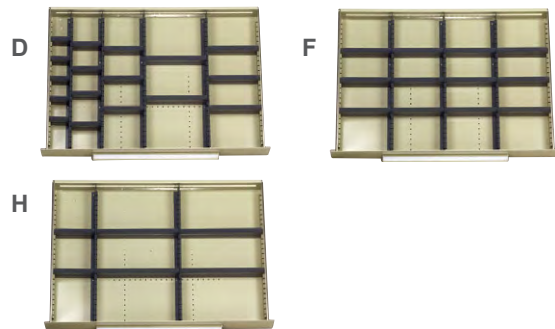
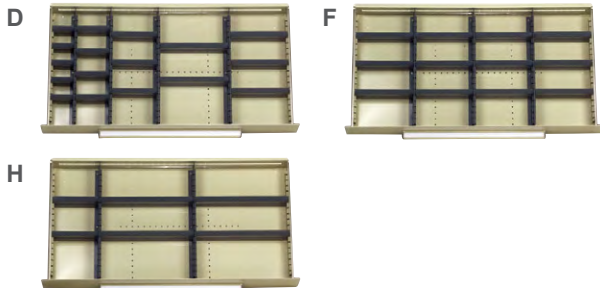

A standard color chart is available on page 150.

45" Wide Modular Drawer Cabinets

NEW! All Cabinets Include a Lock

- Use these modular drawer cabinets to organize more of your items in less floor space.
- High quality welded steel construction
- Precision engineered
- Each unit includes one lifting base cover (#6841)
- 400 pound capacity per drawer
- 100% drawer extension
- Saves time
- Useable interior drawer space is 40^{1/8}"W x 25^{1/8}"D



Model 4484

Modular Drawer Cabinets

45" Wide Modular Drawer Cabinets - Preconfigured Units

45" W x 27^{3/4}" D x 38" H

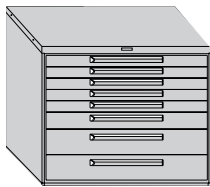

444538-512-01
 Drawer/Dividers included
 (5) 3" h "C" Type
 (1) 4.5" h "C" Type
 (1) 6.75" h "C" Type
 (1) 6.75" h "E" Type
 Order #444538-512MT
 for unit without divider kits.

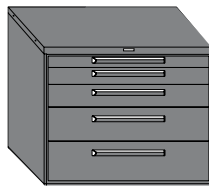

444538-113-01
 Drawer/Dividers included
 (1) 3" h "C" Type
 (1) 4.5" h "C" Type
 (1) 6" h "E" Type
 (1) 9" h "E" Type
 (1) 10.5" h "F" Type
 Order #444538-113MT
 for unit without divider kits.



444538-999-01
 Drawer/Dividers included
 (1) 3" h "C" Type
 (1) 4.5" h "C" Type
 (1) 6" h "C" Type
 (1) 6.75" h "E" Type
 (1) 12.75" h "F" Type
 Order #444538-999MT
 for unit without divider kits.



444538-004-01
 Drawer/Dividers included
 (2) 8.25" h "E" Type
 (1) 8.25" h "C" Type
 (1) 8.25" h "H" Type
 Order #444538-004MT
 for unit without divider kits.

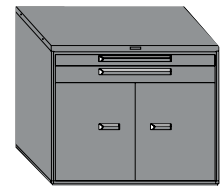

444538-11D-E
 Drawer/Dividers included
 (1) 3" h "E" Type
 (1) 4.5" h "E" Type
 (1) 24" h Flush Cabinet Door
 has a 5 point security channel
 Order #444538-11DMT
 for unit without divider kits.

45" W x 27^{3/4}" D x 44" H



4470H*
 Drawer/Dividers included
 (13) 3" h "H" Type
 Order #4470 for unit
 without divider kits.



4471H*
 Drawer/Dividers included
 (1) 3" h "H" Type
 (8) 4.5" h "H" Type
 Order #4471 for unit
 without divider kits.



4472H*
 Drawer/Dividers included
 (1) 3" h "H" Type
 (6) 6" h "H" Type
 Order #4472 for unit
 without divider kits.



4473H*
 Drawer/Dividers included
 (3) 3" h "H" Type
 (5) 4.5" h "H" Type
 (1) 7.5" h "H" Type
 Order #4473 for unit
 without divider kits.



4474H*
 Drawer/Dividers included
 (3) 3" h "H" Type
 (1) 4.5" h "H" Type
 (1) 6" h "H" Type
 (1) 7.5" h "H" Type
 (1) 12" h "H" Type
 Order #4474 for unit
 without divider kits.

Drawer divider options

*This 45" wide pre-engineered modular drawer unit is also available with either all D or H divider kits (See page 56). To specify, simply add the letter suffix after the first four digits of cabinet model number when ordering. Drop any following digits. Ex: 4480 becomes 4480D.

A standard color chart is available on page 150.

45" W x 27³/₄" D x 59" H



4480H*
Drawer/Dividers included
(18) 3" h "H" Type
Order #4480 for unit
without divider kits.



4481H*
Drawer/Dividers included
(12) 4.5" h "H" Type
Order #4481 for unit
without divider kits.



4482H*
Drawer/Dividers included
(9) 6" h "H" Type
Order #4482 for unit
without divider kits.



4483H*
Drawer/Dividers included
(5) 3" h "H" Type
(7) 4.5" h "H" Type
(1) 7.5" h "H" Type
Order #4483 for unit
without divider kits.



4484H*
Drawer/Dividers included
(3) 3" h "H" Type
(3) 4.5" h "H" Type
(2) 6" h "H" Type
(1) 7.5" h "H" Type
(1) 12" h "H" Type
Order #4484 for unit
without divider kits.

Modular Drawer Cabinets

Drawer divider options

*This 45" wide pre-engineered modular drawer unit is also available with either or all D or H divider kits (See page 56). To specify, simply add the letter suffix after the first four digits of cabinet model number when ordering. Drop any following digits. Ex: 4480 becomes 4480D.

Customizing a Modular Drawer Cabinet

45" W x 27³/₄" D Modular Drawer Cabinets - Components

To customize an Equipto Modular Drawer Cabinet, first select a housing from the following options:

29" High, 33¹/₂" High, 38" High, 44" High or 59" High

Housings

Part No.	Height	Points	Total Drawer Height Value
44369-18	29"	80	24"
44369	33 ¹ / ₂ "	95	28 ¹ / ₂ "
4248	38"	110	33"
4469	44"	130	39"
4479	59"	180	54"

All housings are 45" Wide & 27³/₄" Deep

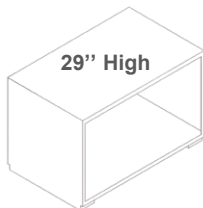

44369-18

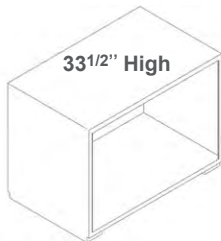

44369

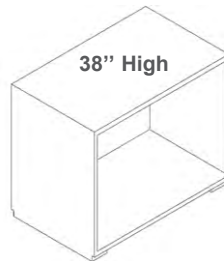

4248

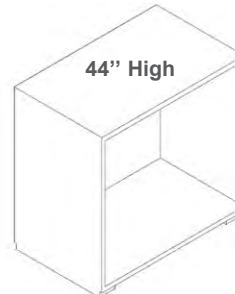

4469

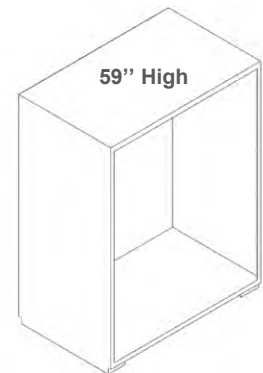

4479

*Add PTF to end of either 4469 or 4479 to get holes punched in the top for stacking units. Order stacking hardware 7751-4.



Lock-in Lock-out feature

RH & LH is available (Add RH to Base Part Number – Ex: 8643-10 to 8643-10RH)

A standard color chart is available on page 150.

Select The Drawers You Want To Put In The Housing.

(Keeping in mind the simple point system, in which the summation of the individual drawer points must equal the total points for the cabinet housing.)

Useable interior drawer space is 40¹/₈" W x 25¹/₈" D

Drawers (400 lbs. Capacity per drawer)



Part No.	Part No.	Part No.	Part No.
8643-10	8643T-12.5	8644-15	8644T-17.5
Height	Height	Height	Height
Front: 3"	Front: 3 ³ / ₄ "	Front: 4 ¹ / ₂ "	Front: 5 ¹ / ₄ "
Body: 2 ¹ / ₈ "	Body: 2 ¹ / ₈ "	Body: 3 ¹ / ₈ "	Body: 3 ¹ / ₈ "
Useable: 2 ¹ / ₄ "	Useable: 3"	Useable: 3 ³ / ₄ "	Useable: 4 ¹ / ₂ "
Points: 10	Points: 12.5	Points: 15	Points: 17.5



Part No.	Part No.	Part No.	Part No.
8645-20	8645T-22.5	8646-25	8646T-27.5
Height	Height	Height	Height
Front: 6"	Front: 6 ³ / ₄ "	Front: 7 ¹ / ₂ "	Front: 8 ¹ / ₄ "
Body: 4 ⁵ / ₈ "	Body: 4 ⁵ / ₈ "	Body: 4 ⁵ / ₈ "	Body: 4 ⁵ / ₈ "
Useable: 5 ¹ / ₄ "	Useable: 6"	Useable: 6 ³ / ₄ "	Useable: 7 ¹ / ₂ "
Points: 20	Points: 22.5	Points: 25	Points: 27.5



Part No.	Part No.	Part No.	Part No.
8647-30	8647T-32.5	8648-35	8648T-37.5
Height	Height	Height	Height
Front: 9"	Front: 9 ³ / ₄ "	Front: 10 ¹ / ₂ "	Front: 11 ¹ / ₄ "
Body: 4 ⁵ / ₈ "	Body: 4 ⁵ / ₈ "	Body: 4 ⁵ / ₈ "	Body: 4 ⁵ / ₈ "
Useable: 8 ¹ / ₄ "	Useable: 9"	Useable: 9 ³ / ₄ "	Useable: 10 ¹ / ₂ "
Points: 30	Points: 32.5	Points: 35	Points: 37.5

A standard color chart is available on page 150.

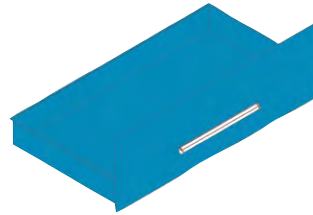

Part No.	Part No.	Part No.	Part No.
8649-40	8649T-42.5	8650-45	8650T-47.5
Height	Height	Height	Height
Front: 12"	Front: 12 ³ / ₄ "	Front: 13 ¹ / ₂ "	Front: 14 ¹ / ₄ "
Body: 4 ⁵ / ₈ "	Body: 4 ⁵ / ₈ "	Body: 4 ⁵ / ₈ "	Body: 4 ⁵ / ₈ "
Useable: 11 ¹ / ₄ "	Useable: 12"	Useable: 12 ³ / ₄ "	Useable: 13 ¹ / ₂ "
Points: 40	Points: 42.5	Points: 45	Points: 47.5

Modular Drawer Cabinets

Select divider sets for each drawer

that will help you maximize your storage space within each drawer. Divider Sets are optional, and are not required to order a cabinet. All dividers are smooth office gray in color.



Divider kits - 45" wide

Divider Set	For 3" High Drawer	For 4 ¹ / ₂ " High Drawer	For 6" High and Up Drawer
Type C	4143C10	4144C15	4145C20
Type D	4143D10	4144D15	4145D20
Type E	4143E10	4144E15	4145E20
Type F	4143F10	4144F15	4145F20
Type H	4143H10	4144H15	4145H20

C

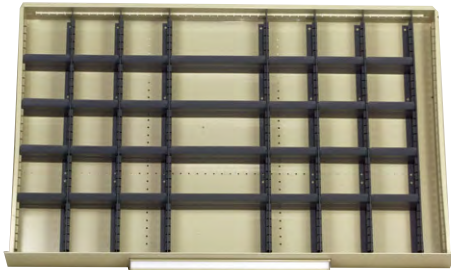

D

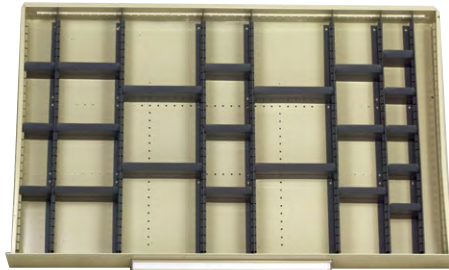

E

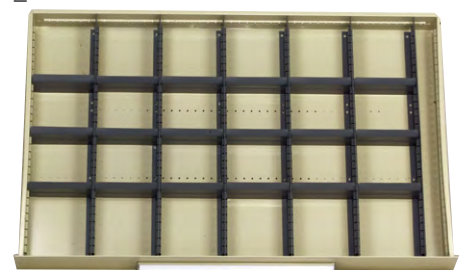

F

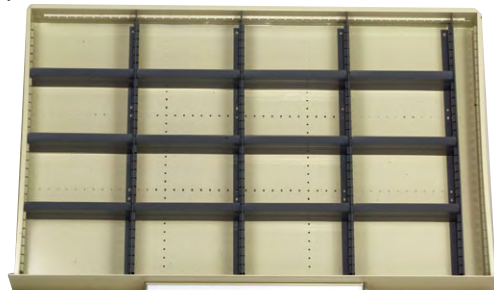

H



A standard color chart is available on page 150.

60" Wide Modular Drawer Cabinets

NEW! All Cabinets Include a Lock

- Use these modular drawer cabinets to organize more of your items in less floor space.
- High quality welded steel construction
- Precision engineered
- Saves time
- 400 pound capacity per drawer
- 100% drawer extension
- Each unit includes lifting base cover (#6835)



Model 4461

60" Wide Modular Drawer Cabinets - Preconfigured Units

60" W x 27^{3/4}" D x 38" H

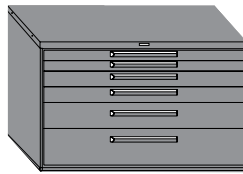

446038-222-01
 Drawer/Dividers included
 (2) 3" h "C" Type
 (2) 4.5" h "C" Type
 (1) 7.5" h "C" Type
 (1) 10.5" h "F" Type
 Order #446038-222MT
 for unit without divider kits.

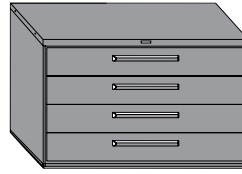

446038-004-E
 Drawer/Dividers included
 (4) 8.25" h "E" Type
 Order #446038-004MT
 for unit without divider kits.

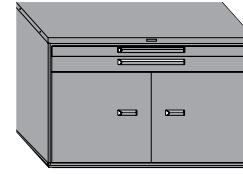

446038-11D-E
 Drawer/Dividers included
 (1) 3" h "E" Type
 (1) 4.5" h "E" Type
 (1) 24" h Flush Cabinet Door
 has a 5 point security channel.
 Order #446038-11DMT
 for unit without divider kits.

60" W x 27^{3/4}" D x 44" H



4450H
 Drawer/Dividers included
 (13) 3" h "H" Type
 Order #4450 for unit
 without divider kits*



4451H
 Drawer/Dividers included
 (1) 3" h "H" Type
 (8) 4.5" h "H" Type
 Order #4451 for unit
 without divider kits*



4452H
 Drawer/Dividers included
 (1) 3" h "H" Type
 (6) 6" h "H" Type
 Order #4452 for unit
 without divider kits*



4453H
 Drawer/Dividers included
 (3) 3" h "H" Type
 (5) 4.5" h "H" Type
 (1) 7.5" h "H" Type
 Order #4453 for unit
 without divider kits*



4454H
 Drawer/Dividers included
 (3) 3" h "H" Type
 (1) 4.5" h "H" Type
 (1) 6" h "H" Type
 (1) 7.5" h "H" Type
 (1) 12" h "H" Type
 Order #4454 for unit
 without divider kits*

Drawer divider options

*This 60" wide pre-engineered modular drawer unit is also available with all C, D, E, F or H divider kits (See page 60). To specify, simply add the letter suffix after the first four digits of cabinet model number when ordering. Drop any following digits. Ex: 4480 becomes 4480D.

60" W x 27³/₄" D x 59" H



4460H
Drawer/Dividers included
(18) 3" h "H" Type
Order #4460 for unit
without divider kits.*



4461H
Drawer/Dividers included
(12) 4.5" h "H" Type
Order #4461 for unit
without divider kits.*



4462H
Drawer/Dividers included
(9) 6" h "H" Type
Order #4462 for unit
without divider kits.*



4463H
Drawer/Dividers included
(5) 3" h "H" Type
(7) 4.5" h "H" Type
(1) 7.5" h "H" Type
Order #4463 for unit
without divider kits.*



4464H
Drawer/Dividers included
(3) 3" h "H" Type
(3) 4.5" h "H" Type
(2) 6" h "H" Type
(1) 7.5" h "H" Type
(1) 12" h "H" Type
Order #4464 for unit
without divider kits.*

Modular Drawer Cabinets

Drawer divider options

*This 60" wide pre-engineered modular drawer unit is also available with either all D, E, F or H divider kits (See page 60). To specify, simply add the letter suffix after the first four digits of cabinet model number when ordering. Drop any following digits. Ex: 4480 becomes 4480D.



Lock-in Lock-out feature

RH & LH is available (Add RH to Base Part Number – Ex: 8643-10 to 8643-10RH).
LH is available; use part number without "-suffix" at end instead – Ex. 8653LH)

Customizing a Modular Drawer Cabinet

60" W x 27³/₄" D Modular Drawer Cabinets - Components

To customize an Equipto Modular Drawer Cabinet, first select a housing from the following options:

29" High, 33¹/₂" High, 38" High, 44" High or 59" High

Housings

Part No.	Height	Points	Total Drawer Height Value
4458	29"	80	24"
4468	33 ¹ / ₂ "	95	28 ¹ / ₂ "
4258	38"	110	33"
4449	44"	130	39"
4459	59"	180	54"

All housings are 60" Wide & 27³/₄" Deep

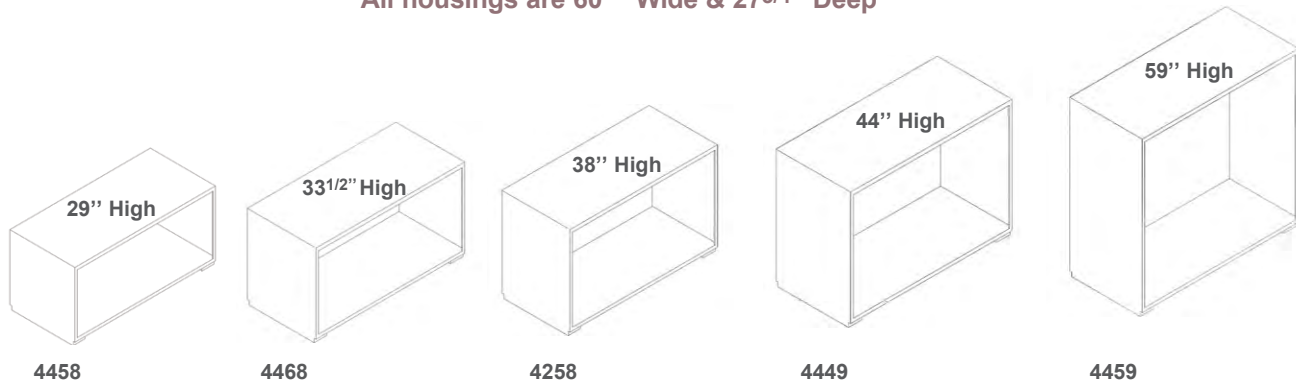

*Add PTF to end of either 4459 to get holes punched in the top for stacking another cabinet on top. Order stacking hardware 7751-4.

A standard color chart is available on page 150.

Select The Drawers You Want To Put In The Housing

(Keeping in mind the simple point system, in which the summation of the individual drawer points must equal the total points for the cabinet housing.)

Useable interior drawer space is 55¹/₈" W x 25¹/₈" D

Drawers (400 lbs. Capacity per drawer)

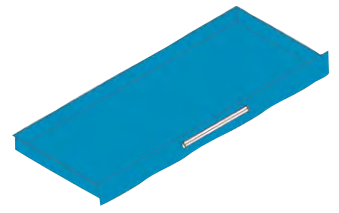

Part No.	Part No.	Part No.	Part No.
8653-10	8653T-12.5	8654-15	8654T-17.5
Height	Height	Height	Height
Front: 3"	Front: 3 ³ / ₄ "	Front: 4 ¹ / ₂ "	Front: 5 ¹ / ₄ "
Body: 2 ¹ / ₈ "	Body: 2 ¹ / ₈ "	Body: 3 ¹ / ₈ "	Body: 3 ¹ / ₈ "
Useable: 2 ¹ / ₄ "	Useable: 3"	Useable: 3 ³ / ₄ "	Useable: 4 ¹ / ₂ "
Points: 10	Points: 12.5	Points: 15	Points: 17.5



Part No.	Part No.	Part No.	Part No.
8655-20	8655T-22.5	8656-25	8656T-27.5
Height	Height	Height	Height
Front: 6"	Front: 6 ³ / ₄ "	Front: 7 ¹ / ₂ "	Front: 8 ¹ / ₄ "
Body: 4 ⁵ / ₈ "	Body: 4 ⁵ / ₈ "	Body: 4 ⁵ / ₈ "	Body: 4 ⁵ / ₈ "
Useable: 5 ¹ / ₄ "	Useable: 6"	Useable: 6 ³ / ₄ "	Useable: 7 ¹ / ₂ "
Points: 20	Points: 22.5	Points: 25	Points: 27.5

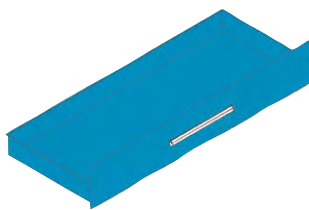
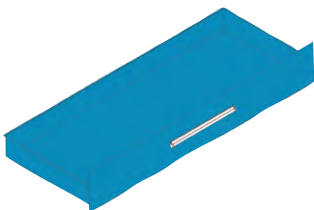

Part No.	Part No.	Part No.	Part No.
8657-30	8657T-32.5	8658-35	8658T-37.5
Height	Height	Height	Height
Front: 9"	Front: 9 ³ / ₄ "	Front: 10 ¹ / ₂ "	Front: 11 ¹ / ₄ "
Body: 4 ⁵ / ₈ "	Body: 4 ⁵ / ₈ "	Body: 4 ⁵ / ₈ "	Body: 4 ⁵ / ₈ "
Useable: 8 ¹ / ₄ "	Useable: 9"	Useable: 9 ³ / ₄ "	Useable: 10 ¹ / ₂ "
Points: 30	Points: 32.5	Points: 35	Points: 37.5

A standard color chart is available on page 150.

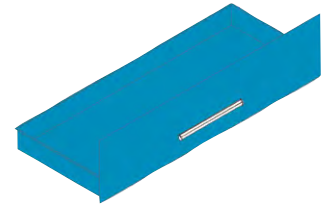
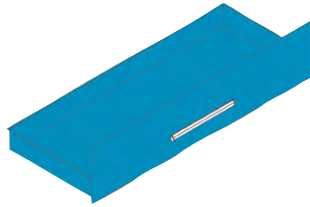
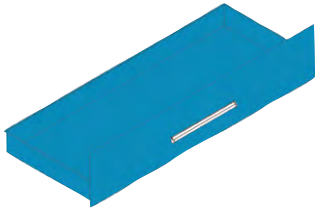

Modular Drawer
Cabinets

Part No.	Part No.	Part No.	Part No.
8659-40	8659T-42.5	8660-45	8660T-47.5
Height	Height	Height	Height
Front: 12"	Front: 12 ³ / ₄ "	Front: 13 ¹ / ₂ "	Front: 14 ¹ / ₄ "
Body: 4 ⁵ / ₈ "	Body: 4 ⁵ / ₈ "	Body: 4 ⁵ / ₈ "	Body: 4 ⁵ / ₈ "
Useable: 11 ¹ / ₄ "	Useable: 12"	Useable: 12 ³ / ₄ "	Useable: 13 ¹ / ₂ "
Points: 40	Points: 42.5	Points: 45	Points: 47.5

Select divider sets for each drawer

that will help you maximize your storage space within each drawer.
 Divider Sets are optional, and are not required to order a cabinet.
 All dividers are smooth office gray in color.



Divider kits - 60" wide

Divider Set	For 3" High Drawer	For 4 ¹ / ₂ " High Drawer	For 6" High and Up Drawer
Type C	4153C10	4154C15	4155C20
Type D	4153D10	4154D15	4155D20
Type E	4153E10	4154E15	4155E20
Type F	4153F10	4154F15	4155F20
Type H	4153H10	4154H15	4155H20

C



D

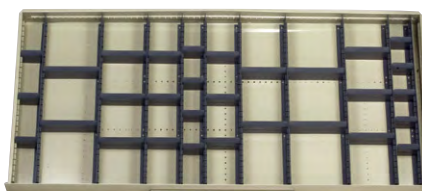

E

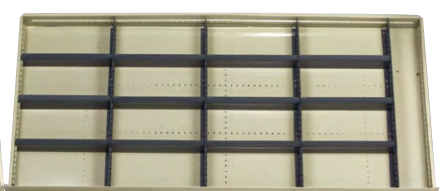

F

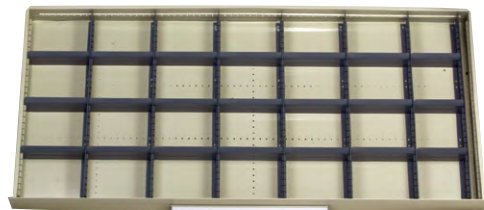

H

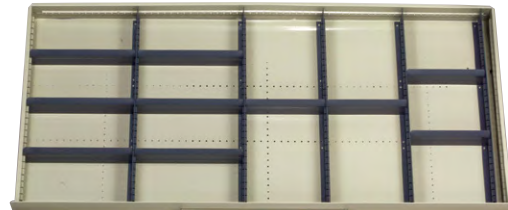

A standard color chart is available on page 150.

Modular Drawer Cabinet Accessories

Accessorize your Equipto Modular Drawer Cabinets. Add dividers, quarter trays, locks, shelves, doors, work surfaces and more to maximize your Equipto System.

Shelves

Stationary or roll-out shelf to be used in conjunction with doors or hinged steel cover that fits flush over modular drawer. Available with optional lock for added drawer security.

Modular Drawer Cabinets



Part No.	Description	Use with:
8633RS	Steel cover – can't use with divider kits	8633 drawer
A 8634RS	Steel cover – can't use with divider kits	8634 drawer
8635RS	Steel cover – can't use with divider kits	8635 drawer
13106	Tumbler lock	Steel cover
B 4403RO	30"W Roll-out concealed shelf	Flush door
4403RO-45	45"W Roll-out concealed shelf	Flush door
4403RO-60	60"W Roll-out concealed shelf	Flush door
C 4403C	30"W Adjustable concealed shelf	Flush door
4403C-45	45"W Adjustable concealed shelf	Flush door
4403C-60	60"W Adjustable concealed shelf	Flush door
4405	30" W Stationary shelf (5 pts.)	External Mount Door
4403RO-22H	22 1/2"W 400 lbs. cab. only, Roll-out concealed shelf	
4403C-22H	22 1/2"W 400 lbs. cab. only, Adjustable concealed shelf	
821122	22 1/2"W 200 lbs. cab. only, Adjustable concealed shelf	
4403C-3618	36"W x 18"D Adjustable concealed shelf	
4403C-3624	36"W x 24"D Adjustable concealed shelf	
7751-4	Hardware for stacking Modular Drawer Cabinets	
MDCH-CAB	Hardware for connecting side-by-side cabinets (drilling required)	



Door assemblies

Use flush mount doors in conjunction with concealed shelves or use swinging door assemblies over entire cabinet front. Must purchase at least one concealed shelf on bottom.

Swinging doors (External mount)

Part No.	For Cabinet
4401	44" H x 30" W
4402	59" H x 30" W
4402-36	59" H x 36" W

Cabinet Tops

Create an excellent work surface or counter top by adding a solid hardwood laminated, stainless steel, wood, or combination top to any modular drawer cabinet.

Part No.	Description
441-3W	30" x 30" Solid hardwood laminate
441-5W	30" x 60" Solid hardwood laminate
441-6W	30" x 72" Solid hardwood laminate
445-30SSW4	Stainless - 30" W x 27 ^{3/4} " D
441-3B	Bonded Wood - 30" W x 30" D
445-30SSW4	stainless steel w/ wood core – 27 3/4"D x 30"W x 3/4" thick
445-45SSW4	stainless steel w/ wood core – 27 3/4"D x 45"W x 3/4" thick
445-90SSW4	stainless steel w/ wood core – 27 3/4"D x 90"W x 3/4" thick
MDCC-222S	stainless steel "skin" cover for (1) 22 1/2" 200 lb. wide cabinets
MDCC-224S	stainless steel "skin" cover for (1) 22 1/2" 400 lb. wide cabinets
MDCC-30S	stainless steel "skin" cover for (1) 30" wide cabinet
MDCC-230S	stainless steel "skin" cover for (2) 30" wide cabinets
MDCC-330S	stainless steel "skin" cover for (3) 30" wide cabinets
MDCC-430S	stainless steel "skin" cover for (4) 30" wide cabinets
MDCC-45S	stainless steel "skin" cover for (1) 45" wide cabinet
MDCC-245S	stainless steel "skin" cover for (2) 45" wide cabinets
MDCC-60S	stainless steel "skin" cover for (1) 60" wide cabinet
MDCC-260S	stainless steel "skin" cover for (2) 60" wide cabinets

*Stainless skin covers are a cost-effective alternative when stainless steel is preferred, but the wood core is not required.

Swinging doors – Flush mount (22 1/2"W available on page 43)

For Cabinet	Part No.	Width	Height	Points
1 Door				
	4197-19	30"	19 1/2"	65
	4197-22	30"	22 1/2"	75
	4197-24	30"	24"	80
	4197-28	30"	28 1/2"	95
	4197-33	30"	33"	110
	4197-39	30"	39"	130
	4197-54	30"	54"	180
	4309SWD	36"	24"	80
2 Doors				
	44369-18SWD	45"	24"	80
	44369SWD	45"	28 1/2"	95
	4248SWD	45"	33"	110
	4469SWD	45"	39"	130
	4479SWD	45"	54"	180
	4045	45"	Security Channel*	5
	4458SWD	60"	24"	80
	4468SWD	60"	28 1/2"	95
	4258SWD	60"	33"	110
	4449SWD	60"	39"	130
	4459SWD	60"	54"	180
	4060	60"	Security Channel*	5
	4101SLD	Swinging Door Padlock Option (for 45" & 60" only)		

*A security channel is required when a double door is mounted beneath.



A standard color chart is available on page 150.

Mobile Unit Kit

Equipto's distinct line of Modular Drawer Cabinets represents a true system-within-a-system.

Convert any 22", 30" or 36" wide by 29" or 33¹/₂" high modular cabinet to an easy-to-manuever mobile unit. Kit includes four 6" diameter wheels (2 swivel, 2 rigid), chrome-plated handle and hardware. Lock-in/Lock-out feature, cabinet lock, or both are recommended. Caster kits raise cabinet up 7¹/₂". If painted handle desired, part #531002.

Mobile base kits for multiple cabinets (handle not included)

- Part No. 4404 22" or 30" wide cabinet, 1200 lb. capacity
- Part No. 4404-24 36" wide cabinet, 24" deep, 1200 lb. capacity
- Part No. 531000-60 For (2) 30"W cabinets
- Part No. 531000-245 For (2) 45"W cabinets
- Part No. 531000-330 For (3) 30"W cabinets
- Part No. MDCH-CAB Side-by-side cabinet hardware
- Part No. 849103 Leg extension kit – add 6" in height

Sloping supervisor desk top

Top is 30" W x 29" D x 6⁷/₈" H

Part No 294



Cabinet locks

Cabinet Width	Part No.
27³/₄" Depth	
22 ¹ / ₂ ", 30", 45" and 60"	4101
22 ¹ / ₂ ", 30", 45" and 60"	4101KA (Keyed alike)
18" Depth	
18" x 36"	4101-18
18" x 36"	4101KA-18 (Keyed alike)
24" Depth	
24" x 36"	4101-24
24" x 36"	4101KA-24 (Keyed alike)

Two keys included per lock.

Keys

Master Key	10429M
Key	10429*

*Specify lock number when ordering

File Drawers

Part No.	Description
8639HF40	27" deep, 12" high drawer includes hanging file frames (Part No. 10268), letter size, set of two. Holds contents of two file drawers.
10430	Fits 30" wide frames. File drawer holds pendaflex files.
8607FA	File drawer holds pendaflex folders. 12"H for 18" D by 36" W shelving or cabinets.
8667HFA	File drawer for 12" H x 18" D x 48" W shelving or cabinets.

Lock-In Lock-Out feature not available.

EQUIPTO File Cabinets must be floor anchored to prevent tipping over if multiple drawers are opened!

Drawer inserts

Description	For Cabinet Width	Part No.
3/8" Plywood	30"	10116
Rubber Mat	30"	10146
Rubber Mat	22 ¹ / ₂ "	10146-22
Rubber Mat	36" (19" Deep)	10146-36-18
Rubber Mat	36" (25" Deep)	10146-36-24
Rubber Mat	45"	10146-45
Rubber Mat	48" (18" Deep)	10146-48-18
Rubber Mat	48" (24" Deep)	10146-48-24
Rubber Mat	60"	10146-60

Plastic Bins & Trays

Description	Part No.
Plastic bins; 2"H x 2"W x 3"L; 30" fill drawer. 96 bins	10122
Plastic bins; 2"H x 3"W x 4"L; 30" fill drawer. 48 bins	10123
Plastic bins; 2 ³ / ₄ "H x 2"W x 3"L; 30" fill drawer. 96 bins	10124
Plastic bins; 2 ³ / ₄ "H x 3"W x 4"L; 30" fill drawer. 48 bins	10125
Quarter trays (20 compartments); 1 ¹ / ₄ " x 12 ¹ / ₂ " x 12 ¹ / ₂ "	10120
Quarter trays (35 compartments); 1 ¹ / ₄ " x 12 ¹ / ₂ " x 12 ¹ / ₂ "	10121



Hinged locking bars (cannot be used on 200 lb. 22¹/₂" cabinets)

Cabinet Height	Part No.	Actual Lock Bar Length
29"	4103-29	23 ¹ / ₂ "
33 ¹ / ₂ "	4103-33	28"
38"	4103-38	32 ¹ / ₂ "
44"	4103-44	38 ¹ / ₂ "
59"	4103-59	53 ¹ / ₂ "

Pad lock or locking device not included.

Plastic bins

Sturdy, plastic bins fit neatly into modular drawers to make counting, sorting and dispensing operations easier, more efficient.

Note: For conductive plastic bins and quarter trays, add C to part number.

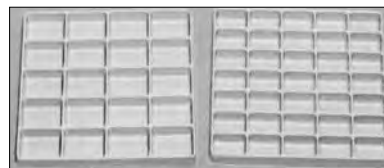
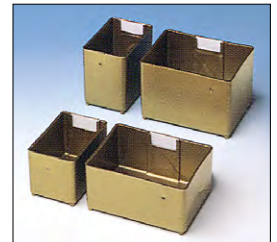

Quarter trays

Quarter trays of molded plastic have 20 or 35 compartments to fit inside modular drawers to hold small parts and supplies.

See sizes and Part No. 10120 and 10121 in the chart to the left.

Trays are actually black, but shown in color for depth.

A standard color chart is available on page 150.

Modular Drawer Cabinets

Modular Drawer Cabinet Accessories Continued

Description	Part No.
Mylar cover strip 18 ^{11/16} "L	951102H
Mylar cover strip 21 ^{3/4} "L (for old style, obsolete handle)	10106
Paper label 18 ^{11/16} "L	951101H
Paper label 21 ^{1/2} "L (for old style, obsolete handle)	10107
Modular drawer handle - specify color - (painted same as cabinet)	218907H
Clear Plastic end cap for left side handle	993102L
Clear Plastic end cap for right side handle	993102R
Black Plastic end cap for left side handle	993102LB
Black Plastic end cap for right side handle	993102RB
Brushed Aluminum Handle with black caps	218908HK
Black Plastic end cap for Brushed Aluminum left side handle	993102LB
Black Plastic end cap for Brushed Aluminum right side handle	993102RB
Side-by-side connecting hardware	MDCH-CAB

Modular Drawer Cabinets

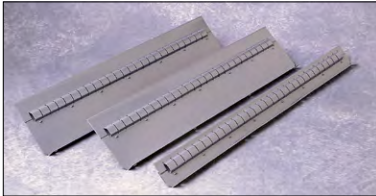

Individual dividers

To further expand the possibilities in creating your own drawer design, we offer a variety of individual dividers. Use them with front-to-back partitions to make compartments of all sizes.

Spaces across drawers:

- 22^{1/2}" W — 24 spaces, 200 lbs. cab. (400 lbs. — 23 sp.)
- 30" W — 32 spaces,
- 36" W — 40 spaces,
- 45" W — 48 spaces,*
- 60" W — 68 spaces*

*Requires one extra partition per drawer

All partitions and dividers are smooth office gray in color

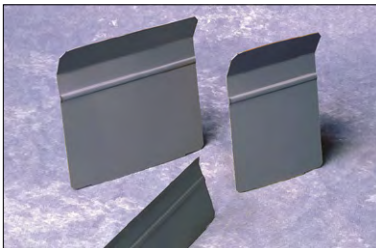

Dividers

Width	For 3" High Drawers	For 4 ^{1/2} " High Drawers	For 6" High and Larger Drawers
Divider Height	2"	3"	4 ^{1/2} "
3 ^{3/32} " (4 spaces)	8834	8844	8854
4 ^{11/16} " (6 spaces)	8835	8845	8855
6 ^{9/32} " (8 spaces)	8836	8846	8856
7 ^{7/8} " (10 spaces)	8837	8847	8857
9 ^{7/16} " (12 spaces)	8838	8848	8858
12 ^{11/16} " (16 spaces)	8839	8849	8859



Electrical power center

Compact, with 4 outlets, On-Off switch, 15 Amp breaker, 15ft. cord with ground.

Easy to install where you need it.

Power Center #229-4



Leveler Kit

Part No. 10067 - 2 per lift channel required

EQUIPTO announces a leveling feature for modular cabinets. Developed for applications where floors are uneven, the leveling device provides 5/8" of vertical adjustment with a 15-degree swivel foot offering optimum stability. Rated at 1,500 lbs. of static loading, each leveler can accommodate the most stringent loading requirements.

Partitions

Ribbed and slotted partitions fit neatly into drawers, running full depth of drawer from front-to-back or full width from side to side. Adjustable in 3/4" increments, they may be used alone, or with dividers. Metal screws supplied for fastening to drawer bottoms. Since 30"-wide drawers are symmetrical, partitions may also be used from side-to-side.

Full depth partitions (front to back)

Partition Height	To Fit Drawer Height	To Fit 18" Deep Drawers	To Fit 24" Deep Drawers	To Fit 27 ^{1/4} " Deep Drawers
2"	3"	8780N	8790N	8726
3"	4 ^{1/2} "	8781N	8791N	8727
4 ^{1/2} "	6" and up	8782N	8792N	8728

Full width partitions (left to right)

Partition Height	To fit Drawer height	To fit Cabinet width	Part. No.
2"	3"	36"	8770
3"	4 1/2"	36"	8771
4 1/2"	6" & up	36"	8772
2"	3"	45"	8743
3"	4 ^{1/2} "	45"	8744
4 ^{1/2} "	6" & up	45"	8745
2"	3"	60"	8736
3"	4 ^{1/2} "	60"	8737
4 ^{1/2} "	6" & up	60"	8738



Label Holder for individual dividers Part No. 6609

Anchor bolt

These bolting options allow you to anchor a modular drawer cabinet to either concrete or wood floors.

Part No.	Description
MDC-CFAK	concrete anchor bolts
MDC-WFAK	wood anchor bolts



MDC-CFAK



MDC-WFAK

Shelving cabinets

Description	Part No.
45"W x 27^{3/4}"D	
38" H cabinet with one adjustable shelf	849143
38" H cabinet with sliding doors	849155
45" W extra shelf	16300-45
44" H sliding door	4496-44
36"W x 27^{3/4}"D	
38" H cabinet with one adjustable shelf	849181
38" H sliding doors	849190
44" W cabinet with one adjustable shelf	849170
36" W extra shelf	849179
60"W x 27^{3/4}"D	
33 ^{1/2} "H cabinet with one adjustable shelf	4492
38" H cabinet with one adjustable shelf	46078
44" H cabinet with one adjustable shelf	4493
59" H cabinet with two adjustable shelves	4495
Extra shelf	16300

Sliding doors w/lock

33 ^{1/2} " H for #4492	4490-33
44" H for #4493	4490-44
59" H for #4495	4490-59

Hardwood top

30" D x 60" W 441-5W
Ships knocked down

- Heavy steel counter units engineered for simple assembly in continuous rows, or easy combination with modular drawer cabinets.
- Ideal for factory issue areas, warehouse or workshop.
- Provides continuous counter space with shelving
- Cabinets come with middle shelf 57" long
- Shelf has capacity of 1000 pounds and adjusts on 1^{1/2}" centers
- Optional counter tops available
- Use with modular drawer cabinets to have parts readily available
- See pg 62 for hardware for securing side-by-side cabinets
- Stacking kit 7751-4

Depths and widths are engineered to match up perfectly with modular drawer cabinets. Choose shelving units 33^{1/2}" 44" or 59" high, with adjustable shelves (1^{1/2}" centers) of removable, ribbed decking. Each shelf offers over 1,000 lbs. capacity for heavy, bulk loads.

Special Shelving Units for Tops of Modular Cabinets



Modular Drawer Cabinets

Order modular cabinets to compliment shelving. Here are typical arrangements. Many more are possible.

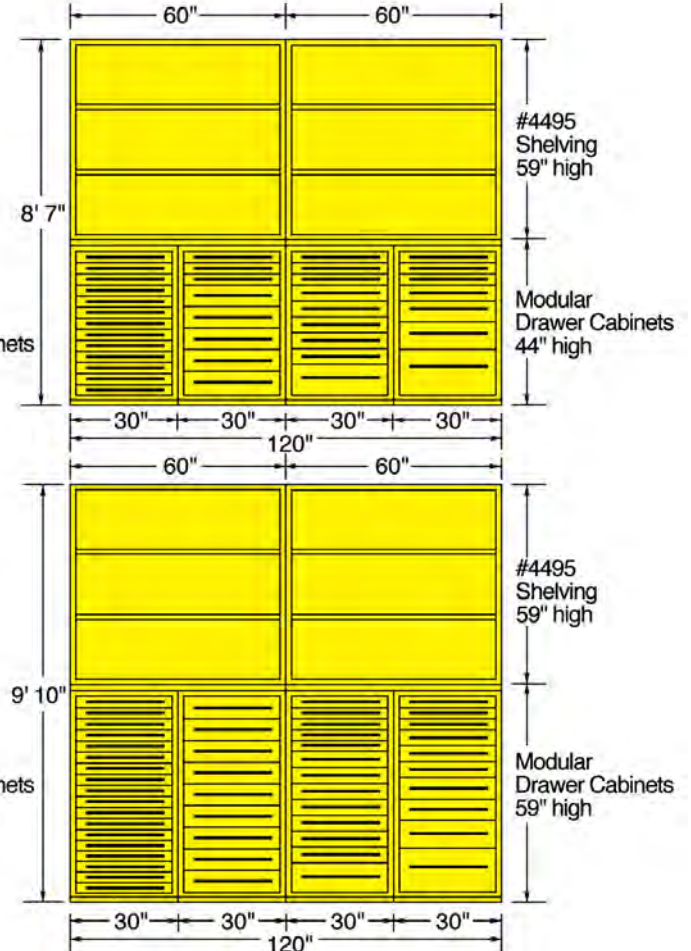
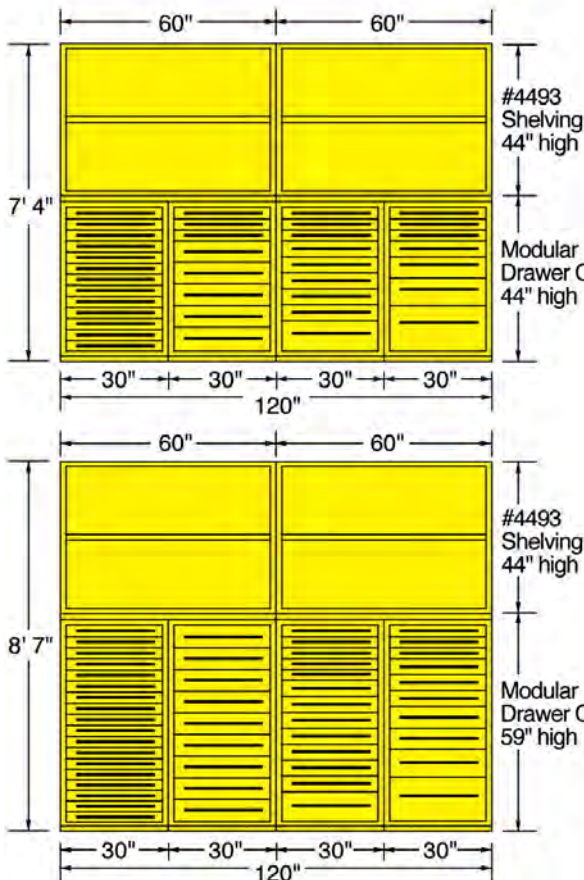

A standard color chart is available on page 150.

FOD/Heavy Duty Mobile Tool Control Cabinets

Mobile Tool Control Cabinets consist of a single, double or triple modular unit with forklift tubes and a caster base. Can be towed or moved with a forklift. Select from four available tops. Drawers are furnished in eight standard heights and have a 400 lb. capacity. Thumb latches are equipped for safety during transportation. Includes frame, base, casters, top and handle only. Order drawers on pg. 48 and 49. Available drawer height value is 28¹/₂"; 95 points.

Foreign object damage cabinets

F.O.D. Workstation 30"D overall

Includes frame, base, casters, top and handle only. Order drawers on pg. 48 and 49. Available drawer height value is 28¹/₂"; 95 points.

Description:	Part No.
A. Single workstation (not pictured) 30" W	
Plastic laminate top	4191P
Painted steel top	4191PS
Stainless steel top	4191SS
Hardwood top	4191W

B. Double workstation 60" W	
Plastic laminate	4192P
Painted steel	4192PS
Stainless steel	4192SS
Hardwood top	4192W

C. Triple workstation 90" W	
Plastic laminate	4193P
Painted steel	4193PS
Stainless steel	4193SS
Hardwood top	4193W

For 45" or 60" cabinet sections please contact Equipto Inside Sales.

Modular Drawer Cabinets



B: Double Workstation
Shown with Double Vertical Display, Tow Bar and optional drawers and door.

- Flush doors available in four heights
- Single, double and triple shadow boxes offered
- Lexan panels provide visibility to shadow boxes
- Sliding door frame has roller bearings and lock
- Stainless steel pull handle
- Heavy duty polyurethane tread casters with sealed roller bearings
- Use for foreign object damage (F.O.D.) applications

Shadow box units

Part No.	Description
4195	Type "1" Single Vertical Display 15"D x 30"W x 30"H
4196	Type "2" Double Vertical Display 15"D x 60"W x 30"H

Box is 24³/₈"D at Base.

Foam Inserts

Part No.	Description
010099-1	for 30" wide drawer
010099-2	for 45" wide drawer
010099-3	for 60" wide drawer

Customize your foam inserts to highlight removed tools and help improve tool accountability.

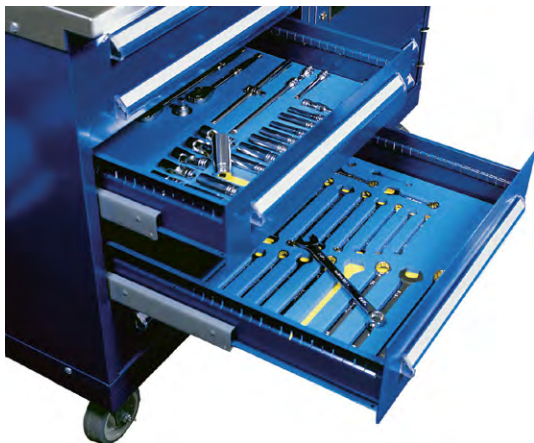

Swinging doors (Flush mount)

Part No.	Description	Points
4197-19	19 ¹ / ₂ " high	65
4197-22	22 ¹ / ₂ " high	75
4197-24	24" high	80
4197-28	28 ¹ / ₂ " high	95

Part No.	Description	Use with
4403C	Stationary shelf*	Swinging door
4403RO	Roll-out concealed shelf	Swinging door
4199	Tow bar	Cabinet
4194	Oversize forklift channel	Cabinet

*One shelf required for cabinet bottom with door.

A standard color chart is available on page 150.

60" Wide Tool Cabinets

Modular Tool Cabinets offer the ability for different storage uses within the same cabinet. With the options including drawers, a door, and a shelf, the uses for a tool cabinet are limitless. Featuring 400 lb drawer capacities, multiple hard top surfaces to choose from, and the ability to add casters for mobility, a tool cabinet is the perfect choice for any application.

- Standard brushed aluminum handles with black end caps
- Single lock system for all drawers
- Doors are keyed differently

Tool Cabinet configurations

Add "M" at end of Part No. to make the unit mobile. Mobile units includes lock-in/lock-out feature, casters and push handle. Cabinet locks are included.

33" H x 60" W x 27 ³ / ₄ " D		
Part No.	Description	
	Left Cabinet Drawers	Right Cabinet Drawers
MDCDB330104	(1) - 3", (2) -5 ¹ / ₄ ", (1) -9"	(3)-3", (2)-3 ³ / ₄ ", (1)-6"
MDCDB330203	(2) -3", (1)-4 ¹ / ₂ ", (1)-12"	(2)-3", (1)-3 ³ / ₄ ", (1)-5 ¹ / ₄ ", (1)-7 ¹ / ₂ "
MDCDB330303	(2)-3", (1)-3 ³ / ₄ ", (1)-5 ¹ / ₄ ", (1)-7 ¹ / ₂ "	(2)-3", (1)-3 ³ / ₄ ", (1)-5 ¹ / ₄ ", (1)-7 ¹ / ₂ "
MDCDB330404	(3)-3", (2)-3 ³ / ₄ ", (1)-6"	(3)-3", (2)-3 ³ / ₄ ", (1)-6"
MDCDB3302SD0	(2) -3", (1)-4 ¹ / ₂ ", (1)-12"	Door, with no shelves
MDCDB3303SD0	(2)-3", (1)-3 ³ / ₄ ", (1)-5 ¹ / ₄ ", (1)-7 ¹ / ₂ "	Door, with no shelves
MDCDB3304SD0	(3)-3", (2)-3 ³ / ₄ ", (1)-6"	Door, with no shelves

38" H x 60" W x 27 ³ / ₄ " D		
Part No.	Description	
	Left Cabinet Drawers	Right Cabinet Drawers
MDCDB381111	(2)-4 ¹ / ₂ ", (1)-6", (1)-12"	(2)-4 ¹ / ₂ ", (1)-6", (1)-12"
MDCDB381212	(1)-4 ¹ / ₂ ", (1)-6", (1)-7 ¹ / ₂ ", (1)-9"	(1)-4 ¹ / ₂ ", (1)-6", (1)-7 ¹ / ₂ ", (1)-9"
MDCDB381311	(1)-3", (2)-4 ¹ / ₂ ", (1)-6", (1)-9"	(2)-4 ¹ / ₂ ", (1)-6", (1)-12"
MDCDB381413	(3)-3", (1)-4 ¹ / ₂ ", (1)-6", (1)-7 ¹ / ₂ "	(1)-3", (2)-4 ¹ / ₂ ", (1)-6", (1)-9"
MDCDB381514	(4)-3", (2)-4 ¹ / ₂ ", (1)-6"	(3)-3", (1)-4 ¹ / ₂ ", (1)-6", (1)-7 ¹ / ₂ "
MDCDB3814SD1	(3)-3", (1)-4 ¹ / ₂ ", (1)-6", (1)-7 ¹ / ₂ "	(1)-3" drawer, 2 Shelves, 1 Door
MDCDB3815SD2	(4)-3", (2)-4 ¹ / ₂ ", (1)-6"	2 Shelves, 1 Door

44" H x 60" W x 27 ³ / ₄ " D		
Part No.	Description	
	Left Cabinet Drawers	Right Cabinet Drawers
MDCDB442325	(1)-4 ¹ / ₂ ", (2)-6", (1)-7 ¹ / ₂ ", (1)-9"	(3)-3", (1)-4 ¹ / ₂ ", (2)-6", (1)-7 ¹ / ₂ "
MDCDB442424	(1)-3", (2)-4 ¹ / ₂ ", (2)-6", (1)-9"	(1)-3", (2)-4 ¹ / ₂ ", (2)-6", (1)-9"
MDCDB442523	(3)-3", (1)-4 ¹ / ₂ ", (2)-6", (1)-7 ¹ / ₂ "	(1)-4 ¹ / ₂ ", (2)-6", (1)-7 ¹ / ₂ ", (1)-9"
MDCDB442622	(4)-3", (2)-4 ¹ / ₂ ", (2)-6"	(2)-4 ¹ / ₂ ", (2)-6", (1)-12"
MDCDB4427SD4	(4)-3", (2)-4 ¹ / ₂ ", (2)-6"	2 Shelves, 1 Door, 1 Lock
MDCDB4425SD3	(3)-3", (1)-4 ¹ / ₂ ", (2)-6", (1)-7 ¹ / ₂ "	(2)-3" drawers, 2 Shelves, 1 Door
MDCDB4426SD4	(4)-3", (2)-4 ¹ / ₂ ", (2)-6"	2 Shelves, 1 Door
MDCDB4425SD4	(3)-3", (1)-4 ¹ / ₂ ", (2)-6", (1)-7 ¹ / ₂ "	2 Shelves, 1 Door

59" H x 60" W x 27 ³ / ₄ " D		
Part No.	Description	
	Left Cabinet Drawers	Right Cabinet Drawers
MDCDB593236	(1)-3", (1)-4 ¹ / ₂ ", (2)-6", (1)-7 ¹ / ₂ ", (1)-9", (1)-12"	(4)-3", (2)-4 ¹ / ₂ ", (1)-6", (1)-7 ¹ / ₂ ", (1)-13 ¹ / ₂ "
MDCDB593335	(1)-4 ¹ / ₂ ", (2)-6", (3)-7 ¹ / ₂ ", (1)-9"	(3)-3", (1)-4 ¹ / ₂ ", (2)-6", (1)-9", (1)-13 ¹ / ₂ "
MDCDB593434	(1)-3", (2)-4 ¹ / ₂ ", (2)-6", (2)-7 ¹ / ₂ ", (1)-9"	(1)-3", (2)-4 ¹ / ₂ ", (2)-6", (2)-7 ¹ / ₂ ", (1)-9"
MDCDB593533	(3)-3", (1)-4 ¹ / ₂ ", (2)-6", (1)-9", (1)-13 ¹ / ₂ "	(1)-4 ¹ / ₂ ", (2)-6", (3)-7 ¹ / ₂ ", (1)-9"
MDCDB593632	(4)-3", (2)-4 ¹ / ₂ ", (1)-6", (1)-7 ¹ / ₂ ", (1)-13 ¹ / ₂ "	(1)-3", (1)-4 ¹ / ₂ ", (2)-6", (1)-7 ¹ / ₂ ", (1)-9", (1)-12"
MDCDB5935SD5	(3)-3", (1)-4 ¹ / ₂ ", (2)-6", (1)-9", (1)-13 ¹ / ₂ "	(1)-3" drawer, 2 Shelves, 1 Door
MDCDB5936SD6	(4)-3", (2)-4 ¹ / ₂ ", (1)-6", (1)-7 ¹ / ₂ ", (1)-13 ¹ / ₂ "	(2)-3" drawer, 2 Shelves, 1 Door
MDCDB5934SD7	(1)-3", (2)-4 ¹ / ₂ ", (2)-6", (2)-7 ¹ / ₂ ", (1)-9"	2 Shelves, 1 Door



Modular Drawer Cabinets

Special configuration shown, highlighting an optional lock-in/lock-out drawer feature.

Contact Equipto Inside Sales for custom configuration options.

Accessories	
Stainless Steel Top	MDCC-60S
Double Bank Cabinet Lock	4101DB

Tool Drawer Options

Modular Drawer Cabinets

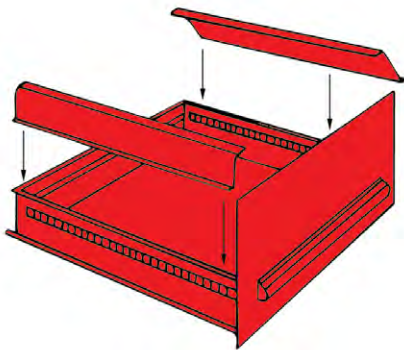

See page 139 for Tool Holders



Support Brackets for Modular Drawer

Modular drawer support brackets attach easily to side panels of any EQUIPTO modular drawer to permit up to four loaded NC tool trays.



Modular Drawer Option

For larger NC tools with greater height than can be accommodated in standard module drawer cabinet units, simply order "open" cabinets and add drawers as needed. Swinging doors provide a finished appearance, plus single-lock security for contents.

Cabinet Width	Fits Modular Drawer No.	Drawer Height	NC Shank Length up to	Catalog # 1 per drawer/comes in pairs	Max no. of 6 ¹ / ₄ " trays per drawer
30"	8633	3"	3 ³ / ₄ "	4129	4
	8634	4 ³ / ₈ "	4 ³ / ₈ "	4128	
	8635 and up	6" and up	5 ¹ / ₈ "	4127	
36"	S8603	3"	3 ³ / ₄ "	4129-18	2
	S8604	4 ¹ / ₂ "	4 ³ / ₈ "	4128-18	
	S8605 and up	6" and up	5 ¹ / ₈ "	4127-18	
	S8610	3"	3 ³ / ₄ "	4129-24	3
	S8611	4 ³ / ₈ "	4 ³ / ₈ "	4128-24	
S8612 and up	6" and up	5 ¹ / ₈ "	4127-24		



Calibration Stand

Specifically designed steel units for use at calibration stations, maintenance areas, etc. Holds two tool trays with easy access. Rests securely on bench top or counter. Trays not included; order trays and holders above.

4106 28"W x 15"D x 12"H

5' High Shelf Unit (Not shown)

Steel unit holds 6 tool trays in 3 stepped levels for easy visibility. Levels adjustable up or down on 1¹/₂" centers. Trays not included; order above.

4107 28"W x 15"D x 5"H



Tool Tray for 36"-wide Shelving

Move tray number 4109-36 between 33¹/₄" long carts, 36⁷/₈" wide drawer cabinets and 36" wide V-Grip shelving (as shown with support brackets 4130-24 for 24"D or 4130-18 for 18"D shelving).



Small Parts Storage



Metal Small Parts Drawers

Drawer Height	4 1/4" Wide	5 5/8" Wide	8 3/8" Wide	11 1/4" Wide
2"	X	X	—	—
3 1/8"	—	X	X	X
4 5/8"	—	X	X	X
6 1/8"	—	X	X	X



2" high shelf drawers

Equipto's rugged 2" drawers slide smoothly and evenly with just fingertip effort. With the added convenience of dividers, the 2" Equipto drawer provides an unbeatable value.

Whether purchased singularly, in multiples for shelving inserts, or in convenient cabinets, Equipto 2" drawers with rigid, quilted sides bring convenience, efficiency and long-term durability.

*All dividers are smooth office gray finish

Small Parts Storage



36/37



8532

8535

2" High shelf drawers

Width	Depth	Height	Height of Stop	Number of Drawers to Make Row Across 3' Wide Shelf	For Shelves Spaced on Centers	Straight Drawer No.	Divider to Fit*
4 1/4"	11"	2"	2 1/2"	8		8532	8732
4 1/4"	17"	2"	2 1/2"	8	Use Frame	8533	8732
5 5/8"	11"	2"	2 1/2"	6		8534	8734
5 5/8"	17"	2"	2 1/2"	6		8535	8734

Note: Drawers ordered individually are not supplied with dividers. Order dividers as desired.

34 1/8" W x 10 5/8" H Preconfigured Cabinets

Drawer Height	Drawer Width	No. of Drawers	No. of Compartments	Part No. 12" Deep	Part No. 18" Deep
2"	4 1/4"	32	96	32	33
2"	5 5/8"	24	72	34	35
2"	4 1/4" / 5 5/8"	16 / 12	84	36	37 (see above)

All units shipped with 2 dividers per drawer.

Note: The above cabinets fit all makes of 36" wide shelving.

Empty Frames for 2"H Drawer Cabinets — Create your own drawer configuration

Width	Depth	Height	Levels	Points per Level	Frame #
34 1/8"	12"	10 5/8"	4	60	10368
34 1/8"	18"	10 5/8"	4	60	10369

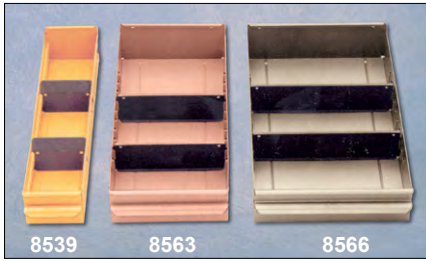

3 1/8" High shelf drawers

One-piece construction with curved handle, reinforced fronts; label holders (full-width on fronts) on both drawers and dividers; embossed bottoms for easy sliding; front and rear drawer stops for pull out, tilt down part retrieval. Insert individual drawers and small cabinets in shelving; stack cabinets high and wide — along walls — back-to-back for partitions — or in rows.

Hundreds of combinations are available for inserting drawers and drawer cabinets into existing shelving (individual drawers shown here.) For example, arranging #8539, #8563 and #8566 drawers in 8-across, 4-across and 3-across patterns converts 36" wide shelf to clean, safe drawer units. Create in-shelf drawers wherever you need them, without replacing existing shelving.



3 1/8" H Individual drawers

Width	Depth of Stop	Height	Height to Make Row Across	Number of Drawers Spaced on Centers	For Shelves to Fit	Drawer No.	Straight Divider 3' Wide Shelf
4 1/4"	11"	3 1/8"	3 7/8"	8	4 1/2"	8504	8709
4 1/4"	17"	3 1/8"	3 7/8"	8	4 1/2"	8539	8709
8 3/8"	11"	3 1/8"	3 7/8"	4	4 1/2"	8553	8753
8 3/8"	17"	3 1/8"	3 7/8"	4	4 1/2"	8563	8753
11 1/4"	11"	3 1/8"	3 7/8"	3	4 1/2"	8556	8756
11 1/4"	17"	3 1/8"	3 7/8"	3	4 1/2"	8566	8756

Note: Drawers ordered individually are not supplied with dividers. Order dividers as desired.

Empty Frames for 3 1/8" H Drawer Cabinets — Create your own drawer configuration

Width	Depth	Height	Levels	Points per Level	Frame #
23"	12"	9 3/8"	2	40	10372
34 1/8"	12"	13 5/8"	3	60	10373
34 1/8"	18"	13 5/8"	3	60	10374



3411 Also available in 3 and 4 across

Drawers on this page will fit any shelving on 4 1/2" centers and all makes of 36" wide shelving.

Note: Drawers ordered individually are not supplied with dividers. Order dividers as desired.

34 1/8" W x 135 8/8" H Preconfigured Cabinets

Cabinet Depth	Drawer Width	Drawer Depth	No. of Drawers	No. of Compartments	Part No.
12"	4 1/4"	11"	24 (8 per row)	72	3411
18"	4 1/4"	17"	24 (8 per row)	72	3417
12"	8 3/8"	11"	12 (4 per row)	36	3426
18"	8 3/8"	17"	12 (4 per row)	36	3486
12"	11 1/4"	11"	9 (3 per row)	27	3420
18"	11 1/4"	17"	9 (3 per row)	27	3480

Note: All units in table supplied with 2 dividers per drawer.

- Easy-to-read labelholder on each slanted top divider
- Straight divider design adjusts easily on 1" center; keeps parts from creeping within drawer
- Drawer front has label holder for easy identification
- Full-width, curved handle for quick, fingertip access in bright plated finish

36" W x 43 1/8" H Iron Grip shelving with drawers (Counter High)

Cabinet Width	Cabinet Depth	No. of Drawers	No. of Compartments	Drawer type	Part No.
36"	12"	54	162	8505	1164AD
36"	18"	54	162	8540	1854

Units supplied with 2 dividers per drawer.



45/8" High shelf drawers

Equipto construction is strong enough for smaller units to be hung or stacked anywhere.

Larger units form convenient countertop work surfaces or efficient wall systems.

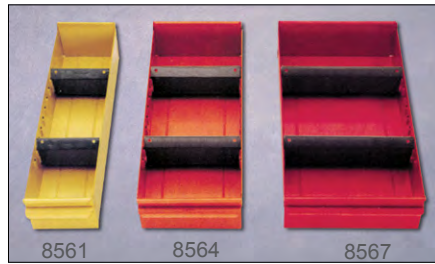

Consider these quality Equipto features; sturdy, one-piece construction with top 2" double thickness steel; built-in, curved handle with full-width label holder; drawer stops both front and rear; adjustable, lock-in dividers with label holders.

Then consider versatility: Insert single drawers and smaller, welded-frame cabinets (34^{1/8"} width) directly into shelving. Stack or hang shorter cabinets anywhere. Use taller units, as free-standing structures.

Insert drawers into your existing shelving in various combinations, #8561 (6-across), #8564 (4-across) and #8567 (3-across) illustrated here. Drawers and small cabinets fit easily between uprights and sit securely on shelving.

45/8" H Individual drawers

Width	Depth	Height of Stop	Height	Number of Drawers to Make Row Across 3' Wide Shelf	For Shelves Spaced on Centers	Drawer No.	Straight Divider to Fit
55/8"	11"	45/8"	53/8"	6	6"	8551	8751
55/8"	17"	45/8"	53/8"	6	6"	8561	8751
83/8"	11"	45/8"	53/8"	4	6"	8554	8754
83/8"	17"	45/8"	53/8"	4	6"	8564	8754
111/4"	11"	45/8"	53/8"	3	6"	8557	8757
111/4"	17"	45/8"	53/8"	3	6"	8567	8757

Note: Drawers ordered individually are not supplied with dividers. Order dividers as desired.

Empty Frames for 45/8" H Drawer Cabinets — Create your own drawer configuration

Width	Depth	Height	Levels	Points per Level	Frame #
341/8"	12"	193/4"	3	60	10379
341/8"	18"	193/4"	3	60	10380

341/8" W x 193/4" H Preconfigured Cabinets

Cabinet Depth	Drawer Width	Drawer Depth	No. of Drawers	No. of Compartments	Part No.
12"	55/8"	11"	18	54	3629
18"	55/8"	17"	18	54	3689
12"	83/8"	11"	12	36	3626
18"	83/8"	17"	12	36	3686
12"	111/4"	11"	9	27	3620
18"	111/4"	17"	9	27	3680

Note: All units have 2 dividers per drawer

36"W x 431/8" H Iron Grip shelving with drawers (Counter High)

Cabinet Depth	Drawer Width	Drawer Depth	No. of Drawers	No. of Compartments	Part No.
12"	111/4"	11"	21 (7 rows of 3)	63	3350
18"	111/4"	17"	21 (7 rows of 3)	63	3360
12"	83/8"	11"	28 (7 rows of 4)	84	3351
18"	83/8"	17"	28 (7 rows of 4)	84	3361
12"	55/8"	11"	42 (7 rows of 6)	126	3352
18"	55/8"	17"	42 (7 rows of 6)	126	3362

Note: All units have 2 dividers per drawer.

Small Parts Storage



3629/3689



3626/3686



3620/3680



3351
3361

3352
3362

Drawers on this page will fit any shelving on 6" centers and all makes of 36" wide shelving.

Note: Cabinet units are shipped with 2 dividers per drawer.

Individual drawers are supplied without dividers; order separately as desired.

6 1/8" High shelf drawers

The highest Equipto drawer - big and rugged, yet simply designed. Ideal for tools, dies, chucks, hardware and hundreds of other boxed, canned or bulk items. Available in 3 widths and 2 depths, these large drawers will handle just about anything you choose to put in them. Simple, effective, safe.

All dividers are smooth office gray in color.

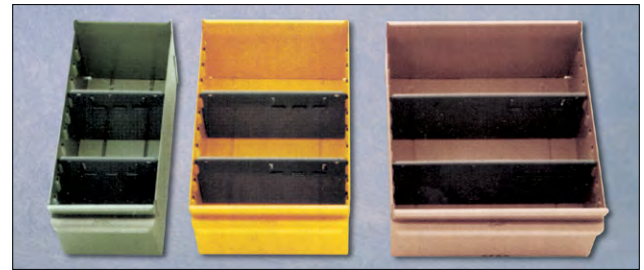

8562

8565

8568

6 1/8" H Individual drawers

Width	Depth	Height	Height of Stop	Number of Drawers to Make Row Across 3' Wide Shelf	For Shelves Spaced on Centers	Part No.	Straight Divider to Fit
5 5/8"	11"	6 1/8"	6 7/8"	6	7 1/2"	8552	8752
5 5/8"	17"	6 1/8"	6 7/8"	6	7 1/2"	8562	8752
8 3/8"	11"	6 1/8"	6 7/8"	4	7 1/2"	8555	8755
8 3/8"	17"	6 1/8"	6 7/8"	4	7 1/2"	8565	8755
11 1/4"	11"	6 1/8"	6 7/8"	3	7 1/2"	8558	8758
11 1/4"	17"	6 1/8"	6 7/8"	3	7 1/2"	8568	8758

Note: Drawers ordered individually are not supplied with dividers. Order dividers as desired.

Small Parts Storage

36"W x 43 1/8"H Iron Grip shelving with drawers

12" depth

Drawer Width	Drawer Depth	No. of Drawers	Part No.
11 1/4"	11"	15 (3/row)	3370
8 3/8"	11"	20 (4/row)	3371
5 5/8"	11"	30 (6/row)	3372

18" depth

11 1/4"	17"	15 (3/row)	3380
8 3/8"	17"	20 (4/row)	3381
5 5/8"	17"	30 (6/row)	3382

Note: All units supplied with 2 straight dividers per drawer.



3370

3371

3372

36"W x 84"H Iron Grip shelving with drawers

12" depth

Drawer Width	Drawer Depth	No. of Drawers	Part No.
11 1/4"	11"	33 (3/row)	3970
8 3/8"	11"	44 (4/row)	3971
5 5/8"	11"	66 (6/row)	3972

18" depth

11 1/4"	17"	33 (3/row)	3980
8 3/8"	17"	44 (4/row)	3981
5 5/8"	17"	66 (6/row)	3982

Note: All units supplied with 2 straight dividers per drawer.



3972

3970

3971

Drawers on this page will fit any shelving on 7 1/2" centers and all makes of 36" wide shelving.

A standard color chart is available on page 150.

Equipto 31/8" drawers offer the widest variety of capacities and combinations ever built into drawer systems.



8505



Small Parts Storage



Drawers on this page will fit any shelving on 4 1/2" centers and all makes of 36" wide shelving.

31/8" H Shelf drawers

Width	Depth	Height	Number of Drawers to Make Row Across 3' Wide Shelf	For Shelves Spaced on Centers	Drawer No.	Straight Divider to fit
55/8"	11"	31/8"	6	4 1/2"	8505	8720
55/8"	17"	31/8"	6	4 1/2"	8540	8720

Note: Drawers ordered individually are not supplied with dividers. Order dividers as desired. Drawers have bright plated finish on handles.

23"W x 93/8"H Cabinets

Cabinet Width	Cabinet Height	No. of Depth	No. of Drawers	Drawer Compartments	Catalog Type	Part No.
23"	9 3/8"	12"	8	24	8505	8

Unit is shipped with 2 dividers per drawer. Drawers have bright plated finish on handles.

34 1/8"W x 13 5/8"H Cabinets

Cabinet Depth	No. of Drawers	No. of Compartments	Drawer Type	Cabinet (drawers included) Part No.
12"	18	54	8505	11
18"	18	54	8540	22
12"	14	42	8505	12

Units supplied with 2 dividers per drawer. Note: The above cabinets fit all makes of 36" wide shelving. Drawers have a bright plated finish on handle (not shown)



Pick Racks

- One bin fits drawer units and open Pick Rack.
- Go from stock to sales area just by exchanging bins.
- Rearrange displays in moments.
- Contents are completely visible.

NOTE — Pick Rack bins are less dividers.
Order dividers, if required, from drawer pages 69–73. All drawers are 11" deep.



30536

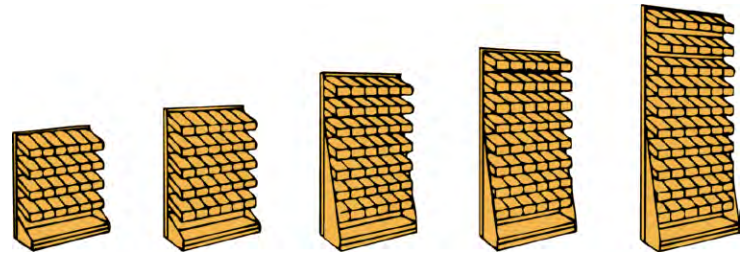

Bin Description	Unit Height — Part No.				
	38 ⁵ / ₈ "	43 ¹ / ₈ "	60"	72"	84"
* #8532 4 ¹ / ₄ " W x 2" H	30328 6 Rows 48 Dwrs.	30428 6 Rows 48 Dwrs.	30528 9 Rows 72 Dwrs.	30628 11 Rows 88 Dwrs.	30728 13 Rows 104 Dwrs.
* #8534 5 ⁵ / ₈ " W x 2" H	30326 6 Rows 36 Dwrs.	30426 6 Rows 36 Dwrs.	30526 9 Rows 54 Dwrs.	30626 11 Rows 66 Dwrs.	30726 13 Rows 78 Dwrs.
* #8505 5 ⁵ / ₈ " W x 3 ¹ / ₈ " H	30336 4 Rows 24 Dwrs.	30436 5 Rows 30 Dwrs.	30536 7 Rows 42 Dwrs.	30636 8 Rows 48 Dwrs.	30736 10 Rows 60 Dwrs.
* #8553 8 ³ / ₈ " W x 3 ¹ / ₈ " H	30334 4 Rows 16 Dwrs.	30434 5 Rows 20 Dwrs.	30534 7 Rows 28 Dwrs.	30634 8 Rows 32 Dwrs.	30734 10 Rows 40 Dwrs.
* #8556 11 ¹ / ₄ " W x 3 ¹ / ₈ " H	30333 4 Rows 12 Dwrs.	30433 5 Rows 15 Dwrs.	30533 7 Rows 21 Dwrs.	30633 8 Rows 24 Dwrs.	30733 10 Rows 30 Dwrs.
* #8551 5 ⁵ / ₈ " W x 4 ⁵ / ₈ " H	30346 3 Rows 18 Dwrs.	30446 4 Rows 24 Dwrs.	30546 6 Rows 36 Dwrs.	30646 7 Rows 42 Dwrs.	30746 8 Rows 48 Dwrs.
* #8554 8 ¹ / ₈ " W x 4 ⁵ / ₈ " H	30344 3 Rows 12 Dwrs.	30444 4 Rows 16 Dwrs.	30544 6 Rows 24 Dwrs.	30644 7 Rows 28 Dwrs.	30744 8 Rows 32 Dwrs.
* #8557 11 ¹ / ₄ " W x 4 ⁵ / ₈ " H	30343 3 Rows 9 Dwrs.	30443 4 Rows 12 Dwrs.	30543 6 Rows 18 Dwrs.	30643 7 Rows 21 Dwrs.	30743 8 Rows 24 Dwrs.
* #8552 5 ⁵ / ₈ " W x 6 ¹ / ₈ " H	30366 3 Rows 18 Dwrs.	30466 3 Rows 18 Dwrs.	30566 5 Rows 30 Dwrs.	30666 6 Rows 36 Dwrs.	30766 7 Rows 42 Dwrs.
* #8555 8 ³ / ₈ " W x 6 ¹ / ₈ " H	30364 3 Rows 12 Dwrs.	30464 3 Rows 12 Dwrs.	30564 5 Rows 20 Dwrs.	30664 6 Rows 24 Dwrs.	30764 7 Rows 28 Dwrs.
* #8558 11 ¹ / ₄ " W x 6 ¹ / ₈ " H	30363 3 Rows 9 Dwrs.	30463 3 Rows 9 Dwrs.	30563 5 Rows 15 Dwrs.	30663 6 Rows 18 Dwrs.	30763 7 Rows 21 Dwrs.

* Order dividers for these bins separately

Put your parts and products where the action is: near the assembly line, at the point of purchase, wherever quick access is needed for sales or production. Parts and products can be put in a bin as received, stocked in cabinets, brought to the point of use, and leftovers returned to stock - all without ever leaving the original bin



To remove bins, lift front up.

Mobile base kit

Steel panel base 30" x 36⁵/₈" has 4 swivel casters on corners and 2 rigid casters in center to hold two pick racks placed back to back for easy movement and pivot around tight corners. Order Pick Racks with bins at right.

Part No. 1186



Small Parts Storage



Mobile Aisles



Mobile Aisle Systems

Equipto's mobile aisle system combines the benefits of high-density storage with the flexibility of V-Grip Shelving, modular drawer and bulk rack. By reducing the number of

access aisles, you can save as much as 50% of your floor space or double your storage capacity in the same space you are currently using.

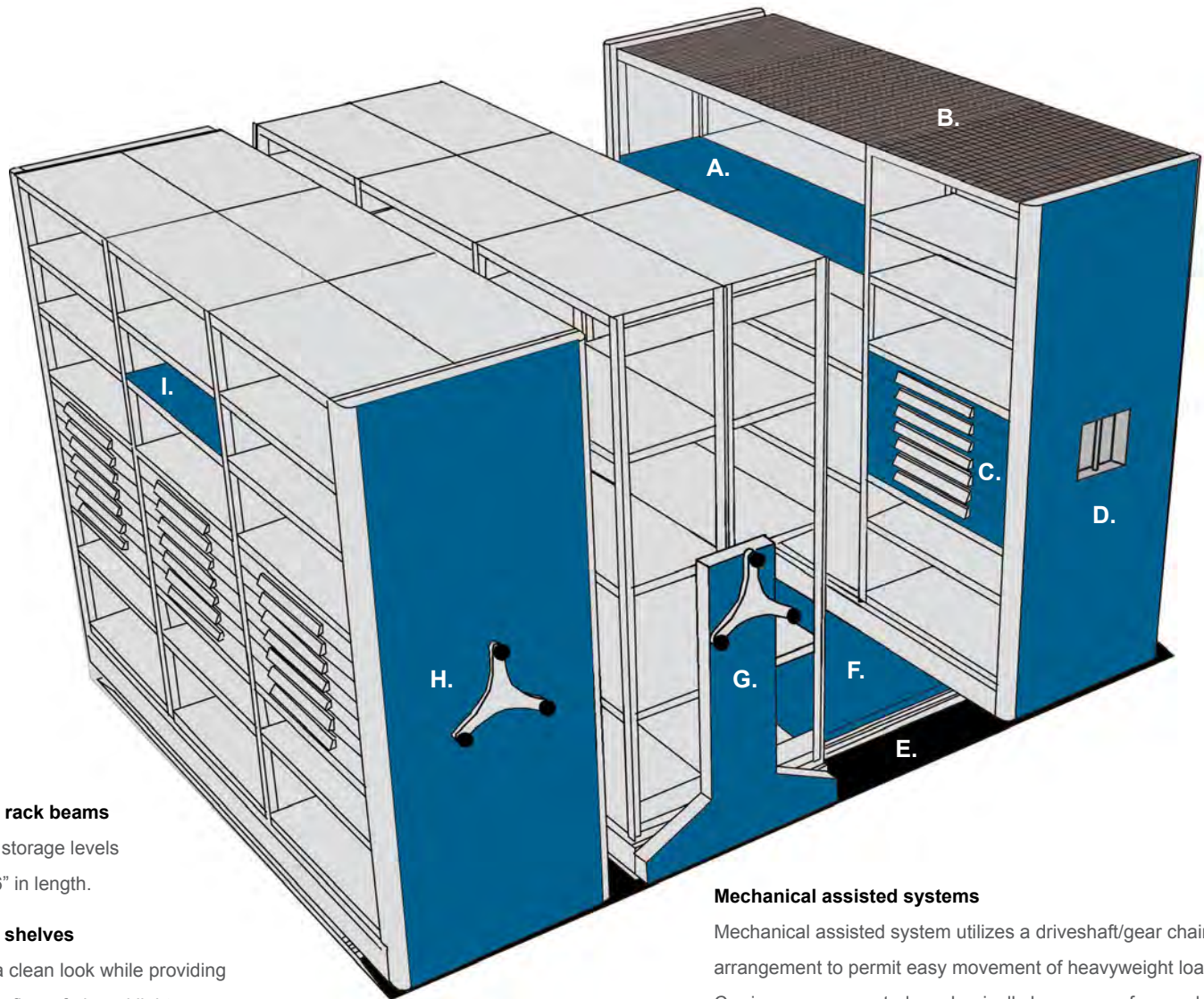

Mobile Aisles

A. Bulk rack beams
provide storage levels up to 96" in length.

B. Wire shelves
Keeps a clean look while providing optimum flow of air and light.

C. Modular drawers 18"D & 24"D
in 48 standard sizes and 200 or 400lb. capacity.

D. Manual drive system
grab and pull function.

E. Ramp
available in standard 12" or 24" to accommodate ADA requirements.

F. Modular platform
surface mounted, leveled tracks and choice of decking.

G. Open/Mechanical style drive column
cost effective while providing greater visibility of items stored in the mobile aisle system.

H. Closed/Mechanical style drive
requires a minimal effort to move 10,000 lbs. of load.

I. Heavy duty wire or solid shelves

J. Fixed Carriage (not shown)
are mounted directly to the tracks or put on the floor using raised foot brackets.

Mechanical assisted systems

Mechanical assisted system utilizes a driveshaft/gear chain arrangement to permit easy movement of heavyweight loads. Carriages are operated mechanically by means of an exclusive ergonomically designed hand wheel which prevents snagging clothing. It requires less strength and energy to operate. It's as easy to turn as the power steering in your car.

A locking feature can be added for extra security.

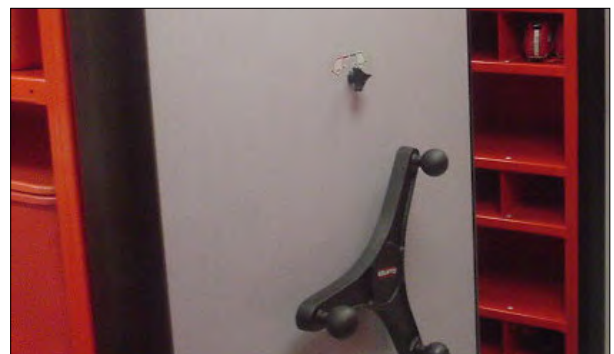

Designing your Mobile Aisle System

Every Mobile Aisle is a customer specific engineered product. A basic sketch of the area and mobile aisle system should be provided, indicating the overall dimensions of the area or room, including doorways, columns, and other obstructions.

Please provide basic size and shelving requirements to ensure accurate quoting.

Please contact Equipto to have a specific unit built to fit your needs.

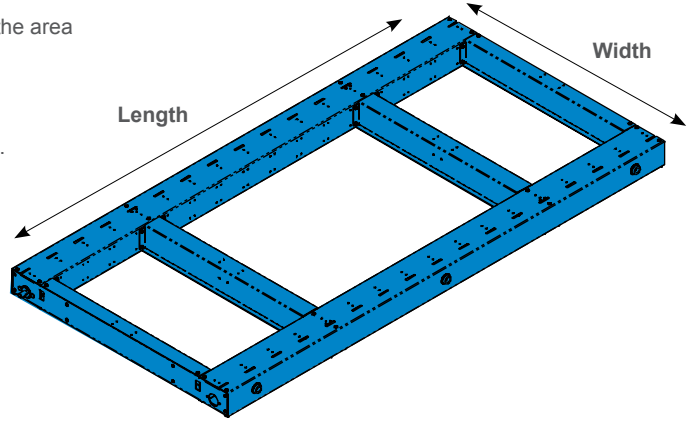

1st - Identify your available space and select your carriage size, decking, and shelving

Select the appropriate carriages by width and length

You have 3 options:

- Fixed Carriage
- Manual Mobile Carriage
- Mechanical Assist Mobile Carriage

All Carriages

Available Lengths: (in feet)

3', 4' and 6' to 36' - not available in 5'

Manual Carriage does not exceed 12' length

Available Widths:

- Fixed Carriage
12", 15", 18", 24", 30", 36", 48"
- Manual Carriage
18", 24", 30", 36", 48"
- Mechanical Assist Carriage
18", 24", 30", 36", 48", 60"

Decking

Mobile Aisle Units offer two decking options:

- Tuffdeck (standard option - shown in image below)
- Plywood

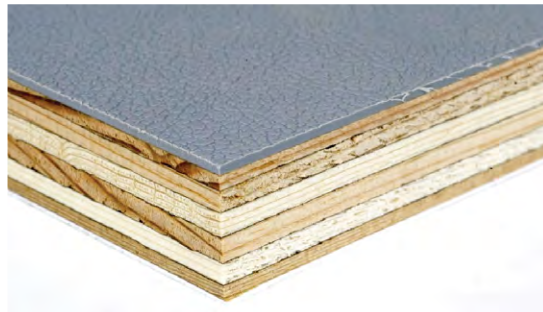

Shelving

Please refer to V-Grip Shelving starting on Page 5 for options.

2nd - Select your Drive Panel

Available Styles: Open and Closed - Open Style Drive Panel is the default selection.

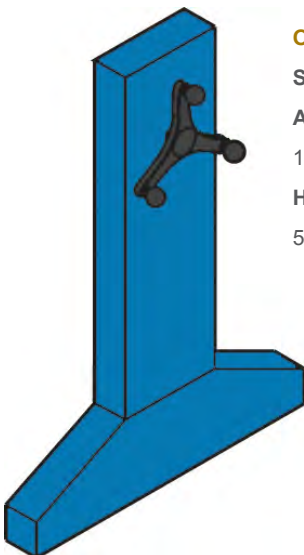

Open/Mechanical Drive Panel

Steel Only

Available widths:

18", 24", 30", 36", 48", 60"

Height:

55"



Closed/Mechanical Drive Panel

Steel or Laminate

Available widths:

18", 24", 30", 36", 48", 60"

Height:

Steel: 60", 78", 85", 90", 97"

Laminate: 78", 85", 90"

60" widths are only available in 85" heights.

A standard color chart is available on page 150.

Select your Drive Panel - cont'd

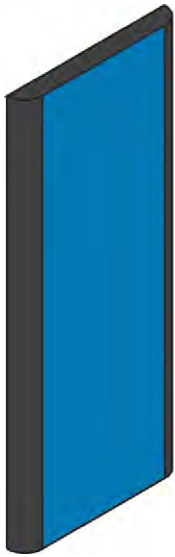

Fixed Drive Panel

Steel or Laminate

Available widths:

12", 15", 18", 24", 30", 36", 48"

Height:

Steel: 60", 78", 85", 90", 97"

Laminate: 78", 85", 90"

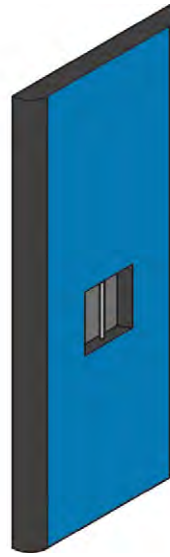

Manual Drive Panel

Steel or Laminate

Available widths:

18", 24", 30", 36", 48"

Height:

Steel: 78", 85", 90"

Laminate: 78", 85", 90"

Drive Shaft End Covers

Available Widths:

12", 15", 18", 24", 30", 36", 48", 60"

Note: Finished End Covers are an inexpensive option to add-on to the end of the carriage to cover mechanical components (drive shaft) extending beyond carriage.

This part can be used in place of an end panel but **WILL NOT** cover the shelving ends.

***Available for Fixed Carriages or opposite end of Manual or Mechanical apps.**

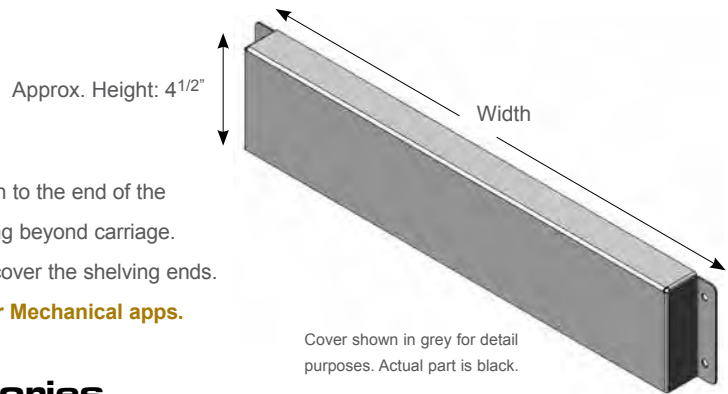

Cover shown in grey for detail purposes. Actual part is black.

Mobile Aisles

Mobile Aisle Systems - Accessories

Anti Tip Brackets

Available Widths:

18", 24", 30", 36", 48", 60"

Use this guideline to determine if anti-tip brackets are required:

18" wide carriage - use if shelving height is over 48"

24" wide carriage - use if shelving height is over 72"

30" wide carriage - use if shelving height is over 96"

36" wide carriage - use if shelving height is over 120"

48" wide carriage - use if shelving height is over 168"

Use the following guideline to determine the quantity of anti-tip brackets needed:

One Required per Mechanical / Manual carriage 3'-6' in length

Two Required per Mechanical / Manual carriage 7'-24' in length

Three Required per Mechanical / Manual carriage 25'-36' in length

Raised Foot Brackets

For fixed carriages located on the floor.

Raised Foot Bracket - Order 2 per track.

Hardware for Brackets - Order 2 per bracket.

Sprocket Options

Heavy load sprocket option

Fast travel sprocket option

Bumper extensions



Deck Skirting

Available Length: 6'

Note: Deck skirt covers the exposed areas at the end of the track. The skirts attach to the decking and are manufactured in 6ft. sections. The last section is cut to length in the field to match installation requirements.

Locking Options

3 options:

Normal or Keyed Alike

Track Base Lock - Keyed lock located on the carriage base, locking into the track. This is the only lock that can be used on manual carriages.

MOBLOCK - Keyed panel lock to secure carriage.

Available upon request. Typically used in last carriage.

Users can collapse the system, lock the last carriage, and the entire system is secured (must use closed-style shelving).

Ideal for high-security items.

Panel Lock - Safety Feature used to lock

hand wheel before entering an aisle.

Included with each mechanical drive panel (Not Keyed).

Panel lock shown in photo to the left.

NEW!



Mobile Aisles

Lateral Mobile Aisle with V-Grip™ Shelving

Make the most of limited space with Equipto's affordable high-density system that dramatically increase storage capacity while still permitting immediate access to all storage areas. Movable, lateral systems consist of stationary shelving in the back row and movable shelving in the front row. The movable shelving units are mounted to mobile carriages that are easily moved from side to side on a heavy-duty track. This type of system is exceptionally flexible, can be easily expanded at any time, and provides fast access to multiple layers of storage.

- Buy complete or integrate with your existing storage equipment
- Lateral Track system creates two or three sliding rows of storage
- Mounted independently to the floor in front of new or existing equipment
- No aisles are required; maximum floor space is utilized
- Perfect for alcoves and limited spaces
- Bi-File (two-row) and Tri-File (three-row) high-density lateral sliding shelving systems are an affordable way to maximize storage capacity
- Double or triple the storage space compared to static shelving

The system works well with virtually any type of inventories/equipment and is effective in maximizing storage capacity along walls in narrow rooms or corridors. The concept of the high-density lateral sliding shelving systems is simple: two or three rows of storage equipment placed in nearly the same footprint where there was once only one!

Standard Shelving Units – 84"H x 18"D, overall height of 90"

Part Number	Dimensions
273-5-2-1-36M System	(2) 36"W Stationary V-Grip™ Closed Shelving Units (1) Mobile 36"W Shelving Unit – Total width 72"
273-5-3-2-36M System	(3) 36"W Stationary V-Grip™ Closed Shelving Units (2) Mobile 36"W Shelving Unit – Total width 108"
273-5-4-3-36M System	(4) 36"W Stationary V-Grip™ Closed Shelving Units (3) Mobile 36"W Shelving Unit – Total width 144"

Motorized Pallet Rack Mobile Aisle System

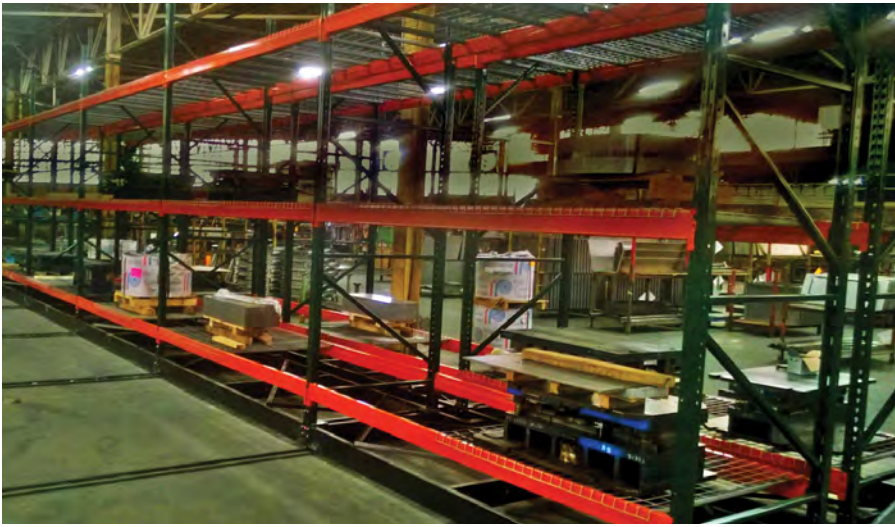

- Fully motorized operation including safety sensors
- Rows up to 50' in length
- Capacity up to 75,000 lbs. per row

Weapons Mobile Aisle System

Mobile aisle system configured to use weapons storage cabinets
(see pages 144-145)



Mobile
Aisles

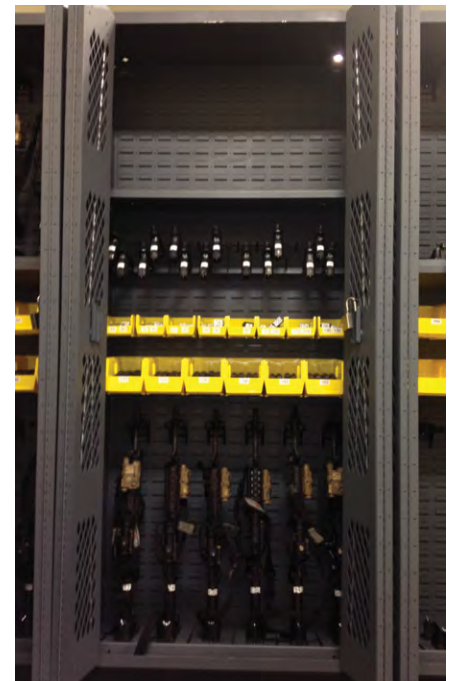
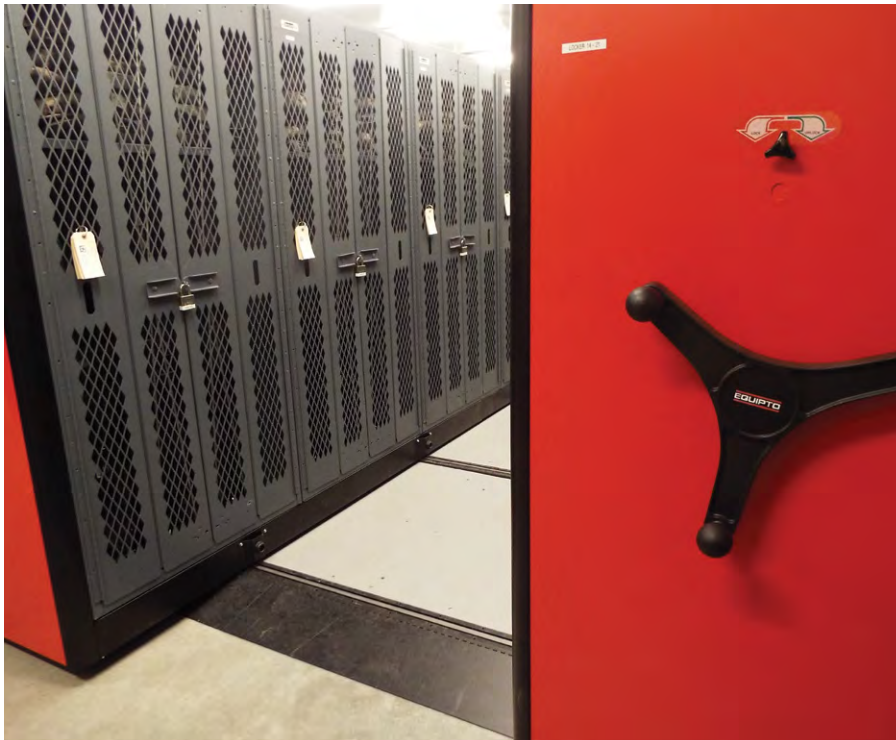

CLUBSTOR

Clubstor® is the premier golf bag storage system. It was developed to offer space saving solutions for country club bag storage rooms. With over 30 years experience and over 500 installations worldwide, Clubstor® is your golf bag storage solution! Clubstor® products are backed with a structural lifetime warranty to the original purchaser. We make every effort to provide you with the best service and highest quality products to meet your specific needs.

Clubstor®



Clubstor® Specialized Golf Club Storage

Clubstor® is the premier golf bag storage system. It was developed to offer space saving solutions for country club bag storage rooms. With over 30 years experience and over 500 installations worldwide, Clubstor® is your golf bag storage solution! Clubstor® products are backed with a structural lifetime warranty to the original purchaser. We make every effort to provide you with the best service and highest quality products to meet your specific needs.



Stationary Units

- Stores 67% more bags in the same space.
- Drastically reduces golf bag retrieval time.
- Provides optimum ventilation to eliminate mildew.
- Middle shelf is adjustable in height, up or down, to fit difficult storage situations.
- Fabricated from all prime steel construction, with no wood components.



Single Sided, 2 Tier Clubstor® (82”H)

Part Number	Depth x Length	Weight
370-1240	15”x50”	97 lbs.
370-1260	15”x60”	109 lbs.
370-1270	15”x72”	123 lbs.
370-1280	15”x84”	137 lbs.
370-1290	15”x100”	157 lbs.

Clubstor

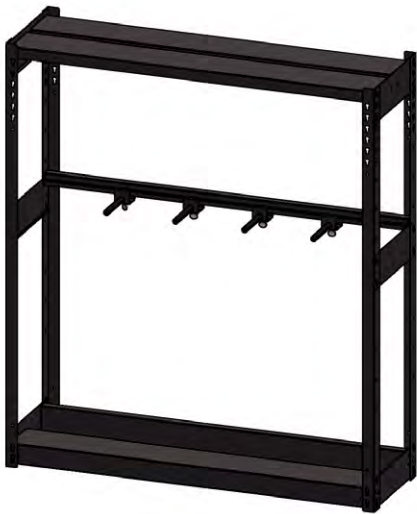

Single Sided, 1 Tier Clubstor® (57”H)

Part Number	Depth x Length	Weight
370-0583	15”x50”	63 lbs.
370-0585	15”x60”	84 lbs.
370-0590	15”x72”	95 lbs.
370-0595	15”x84”	107 lbs.
370-0580	15”x100”	122 lbs.



Double Sided, 2 Tier Clubstor® (82”H)

Part Number	Depth x Length	Weight
370-0220	30”x50”	150 lbs.
370-0230	30”x60”	170 lbs.
370-0240	30”x72”	194 lbs.
370-0250	30”x84”	217 lbs.
370-0200	30”x100”	250 lbs.



Double Sided, 1 Tier Clubstor® (57”H)

Part Number	Depth x Length	Weight
370-0520	30”x50”	97 lbs.
370-0530	30”x72”	134 lbs.
370-0532	30”x84”	150 lbs.
370-0533	30”x100”	171 lbs.

Clubstor® Specialized Mobile Aisles for Golf Club Storage

Mobile Units

- Stores 67% more bags in the same space.
- Drastically reduces golf bag retrieval time.
- Provides optimum ventilation to eliminate mildew.
- Middle shelf is adjustable in height, up or down, to fit difficult storage situations.
- Fabricated from all prime steel construction, with no wood components.



Tandem Double Sided, 1 Tier

Mobile Double Sided, 1 Tier Clubstor®

Part Number	Depth x Length	Weight
370-0535	30"x50"	113 lbs.
370-0540	30"x60"	135 lbs.
370-0544	30"x72"	158 lbs.
370-0548	30"x84"	174 lbs.
370-0550	30"x100"	195 lbs.

In addition, (2) pairs of End Stops and (2) pairs of Track must be ordered for each mobile unit. Contact Equipto Inside Sales.

Mobile Tandem, Double Sided, 1 Tier Clubstor®

Part Number	Depth x Length	Weight
370-0555	50"x72"	195 lbs.
370-0557	60"x72"	285 lbs.
370-0560	72"x72"	316 lbs.
370-0570	84"x84"	347 lbs.

In addition, (4) pairs of End Stops and (4) pairs of Track must be ordered for each mobile unit. Contact Equipto Inside Sales.



Tandem Double Sided, 2 Tier

Mobile Double Sided, 2 Tier Clubstor®

Part Number	Depth x Length	Weight
370-0310	30"x50"	154 lbs.
370-0320	30"x60"	174 lbs.
370-0330	30"x72"	200 lbs.
370-0340	30"x84"	223 lbs.
370-0350	30"x100"	254 lbs.

In addition, (2) pairs of End Stops and (2) pairs of Track must be ordered for each mobile unit. Contact Equipto Inside Sales.

Mobile Tandem, Double Sided, 2 Tier Clubstor®

Part Number	Depth x Length	Weight
370-0410	50"x50"	321 lbs.
370-0420	50"x60"	344 lbs.
370-0430	50"x72"	375 lbs.
370-0440	60"x60"	367 lbs.
370-0450	60"x72"	419 lbs.
370-0460	72"x72"	303 lbs.
370-0463	72"x84"	396 lbs.
370-0465	84"x84"	472 lbs.

In addition, (4) pairs of End Stops and (4) pairs of Track must be ordered for each mobile unit. Contact Equipto Inside Sales.

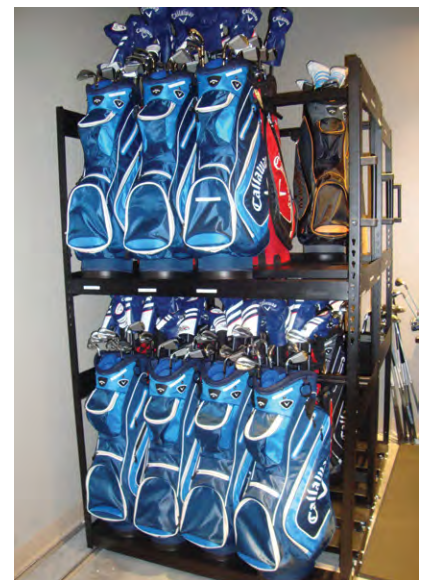

Clubstor

Clubstor® Specialized Golf Accessories Storage

Shelves

Part Number	Dimensions	Capacity
370-5015	15"x50"	250
370-6015	15"x60"	250
370-7215	15"x72"	250
370-5030	30"x50"	250
370-6030	30"x60"	250
370-7230	30"x72"	250

End Panels

Unit	Part Number
Single-Sided 1-Tier Clubstor 57"	372-1557
Single-Sided 2-Tier Clubstor 82"	372-1582
Double-Sided 2-Tier Clubstor 82"	372-3082
Double-Sided 1-Tier Clubstor 27"	372-3057
Mobile Double-Sided 1-Tier Clubstor	372-3057
Mobile Tandem Double-Sided 1-Tier Clubstor	372-3057
Mobile Double-Sided 2-Tier Clubstor	372-3082
Mobile Tandem Double-Sided 2-Tier Clubstor	372-3082

Pull Cart Holders

Part Number	Usage
371-0050	For 50" Long Units
371-0060	For 60" Long Units
371-0072	For 72" Long Units
371-0084	For 84" Long Units
371-0100	For 100" Long Units

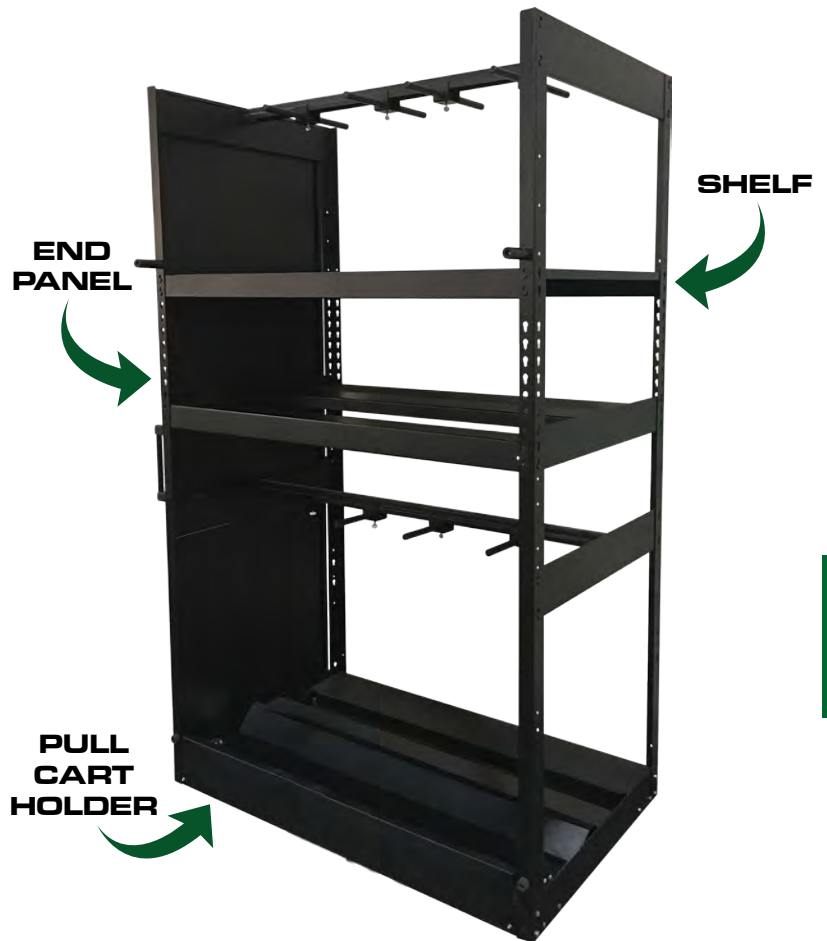

Clubstor

Available in eight standard colors (custom colors available – call for details)

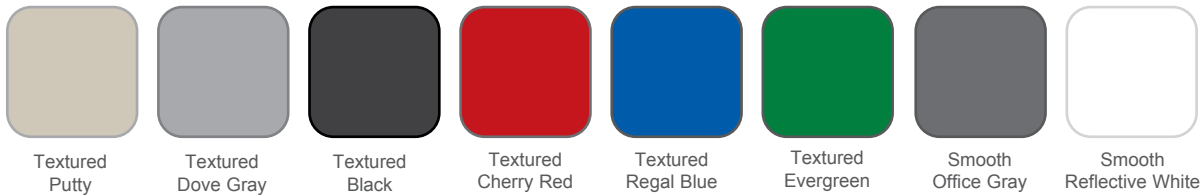



Platforms & Mezzanines



Pre-configured Platforms

Need more space, but don't want to move or add on?

Double or triple your floor space with Equipto pre-fabricated platforms! These rugged elevated floors, walkways and stairways add valuable area where you need it, at a fraction of the cost of acquiring new buildings. Because of their modular design, Equipto platforms are economical, quickly installed and can even be re-configured on your premises as your requirements change.

- Double floor capacity
- Modular design lets you add units as needed
- Less expensive than leasing or Construction
- Relocation to other facilities is easy
- Prefabricated for immediate use
- 36" wide stairway to 4' x 4' landing with OSHA stairs
36" wide stairway to 5'W x 4'D landing with IBC stairs

Decking options include:

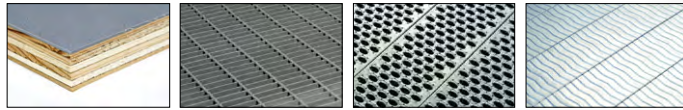

Anti-Skid Tuffdeck Bar Grating Perforated Steel Grating Solid Steel Grating

Rendered image is for visual purposes only. Final product will vary slightly.

They are designed to integrate with other Equipto products to provide one-source space savings that are custom tailored for your individual application. Every place from aircraft hangars to warehouses to factories will benefit from the space saving solutions provided with Equipto platforms!



Photo is a rendered image, the actual product may vary.

Height	Type of Decking	PLATFORM DIMENSIONS (not including stair landing)		
		10'x10'	10'x 20'	8'x12'
OSHA Stairs				
8'	Bar Grating	1010-8GMEZ-BG-17	1020-8GMEZ-BG-17	1208-8GMEZ-BG-17
8'	Perforated Steel Grating	1010-8GMEZ-PG-17	1020-8GMEZ-PG-17	1208-8GMEZ-PG-17
8'	Anti-skid Tuffdeck	1010-8GMEZ-RT-17	1020-8GMEZ-RT-17	1208-8GMEZ-RT-17
8'	Solid Steel Grating	1010-8GMEZ-SG-17	1020-8GMEZ-SG-17	1208-8GMEZ-SG-17
12'	Bar Grating	1010-12GMEZ-BG-17	1020-12GMEZ-BG-17	1208-12GMEZ-BG-17
12'	Perforated Steel Grating	1010-12GMEZ-PG-17	1020-12GMEZ-PG-17	1208-12GMEZ-PG-17
12'	Anti-skid Tuffdeck	1010-12GMEZ-RT-17	1020-12GMEZ-RT-17	1208-12GMEZ-RT-17
12'	Solid Steel Grating	1010-12GMEZ-SG-17	1020-12GMEZ-SG-17	1208-12GMEZ-SG-17

NEW!

IBC Stairs				
8'	Bar Grating	1010-8GMEZ-BG-IBC	1020-8GMEZ-BG-IBC	1208-8GMEZ-BG-IBC
8'	Perforated Steel Grating	1010-8GMEZ-PG-IBC	1020-8GMEZ-PG-IBC	1208-8GMEZ-PG-IBC
8'	Anti-skid Tuffdeck	1010-8GMEZ-RT-IBC	1020-8GMEZ-RT-IBC	1208-8GMEZ-RT-IBC
8'	Solid Steel Grating	1010-8GMEZ-SG-IBC	1020-8GMEZ-SG-IBC	1208-8GMEZ-SG-IBC
12'	Bar Grating	1010-12GMEZ-BG-IBC	1020-12GMEZ-BG-IBC	1208-12GMEZ-BG-IBC
12'	Perforated Steel Grating	1010-12GMEZ-PG-IBC	1020-12GMEZ-PG-IBC	1208-12GMEZ-PG-IBC
12'	Anti-skid Tuffdeck	1010-12GMEZ-RT-IBC	1020-12GMEZ-RT-IBC	1208-12GMEZ-RT-IBC
12'	Solid Steel Grating	1010-12GMEZ-SG-IBC	1020-12GMEZ-SG-IBC	1208-12GMEZ-SG-IBC

Contact your local Equipto Sales Rep to design a custom platform!

Catwalks and Walkways



Ideal for machinery repair, inspection or observation, Equipto Bridge Catwalks can be combined with stairways and ship's ladders to create structures. Versatile, pre-fabricated for easy assembly and engineered for maximum safety and performance.

Platforms & Mezzanines

- Catwalks feature rugged platform frames, 42" high safety railings and 4" high kickplates
- Choose ship's ladders or stairways for access
- 3 pre-configured heights, multiple lengths with add-on units available

Note: Stairways and ship's ladders should be ordered equal to or narrower than catwalk width.

NEW!

OSHA Stairways

Unit Height	Tread Width	Overall Width	Horizontal Stair Run	Stairway Part No.
6'	36"	48 1/2"	6'11"	1836S08
8'	36"	48 1/2"	9'6"	1836S11
10'	36"	48 1/2"	12'0"	1836S14

Ship's Ladders

Unit Height	Tread Width	Overall Width	Horizontal Stair Run	Ladder Part No.
6'	30"	35"	29"	1530L06
8'	30"	35"	35"	1530L08
10'	30"	35"	41"	1530L10

Floor Height	Vertical Clear	Walkway Length	Walkway Width	Catwalk Part No.
6' high unit				
73 5/8"	63 1/2"	2'	48"	976S02
73 5/8"	63 1/2"	4'	48"	976S04
73 5/8"	63 1/2"	6'	48"	976S06
73 5/8"	63 1/2"	8'	48"	976S08
73 5/8"	63 1/2"	10'	48"	976S10
73 5/8"	60 3/4"	12'	48"	976S12
73 5/8"	58"	16'	48"	976S16
73 5/8"	56"	20'	48"	976S20
8' high unit				
97 5/8"	87 1/2"	2'	48"	977S02
97 5/8"	87 1/2"	4'	48"	977S04
97 5/8"	87 1/2"	6'	48"	977S06
97 5/8"	87 1/2"	8'	48"	977S08
97 5/8"	87 1/2"	10'	48"	977S10
97 5/8"	84 3/4"	12'	48"	977S12
97 5/8"	82"	16'	48"	977S16
97 5/8"	80"	20'	48"	977S20
10' high unit				
121 5/8"	111 1/2"	2'	48"	978S02
121 5/8"	111 1/2"	4'	48"	978S04
121 5/8"	111 1/2"	6'	48"	978S06
121 5/8"	111 1/2"	8'	48"	978S08
121 5/8"	111 1/2"	10'	48"	978S10
121 5/8"	108 3/4"	12'	48"	978S12
121 5/8"	106"	16'	48"	978S16
121 5/8"	104"	20'	48"	978S20

Stair Landing Platforms

“Stack-of-Stairs”

Equipto can build a “stack-of-stairs” and platform landings to almost any height.

Contact Equipto Inside Sales for a quote!

	Description	Platform Width	Platform Depth	Floor Height	Part No.
A.	Platform for Straight Through Use Order 36" Wide Stairs	48"	48"	6'	970-06
				8'	970-08
				10'	970-10
				12'	970-12
B.	Platform for 90° Turn, Left or Right Order 36" Wide Stairs	48"	48"	6'	970-06
				8'	970-08
				10'	970-10
				12'	970-12
C.	Platform for 180° Turn Order 36" Wide Stairs	96"	48"	6'	971-06
				8'	971-08
				10'	971-10

- Maximize space
- Double or triple capacity without sacrificing valuable floor space
- Building up is more economical and efficient than building out
- Solidly supported by welded uprights
- Precision engineered
- Significantly increased productivity and profits
- Prefabricated platforms designed according to OSHA and IBC guidelines.
- 125 lbs. per sq. ft. of uniformly distributed weight.
- 150 lbs. per sq. ft. in seismic zone 0 only

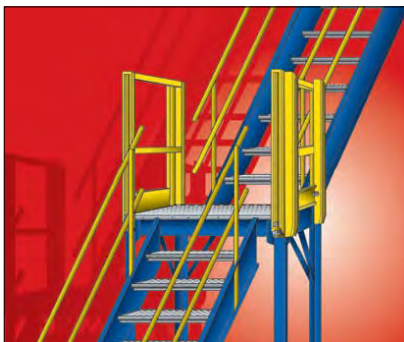
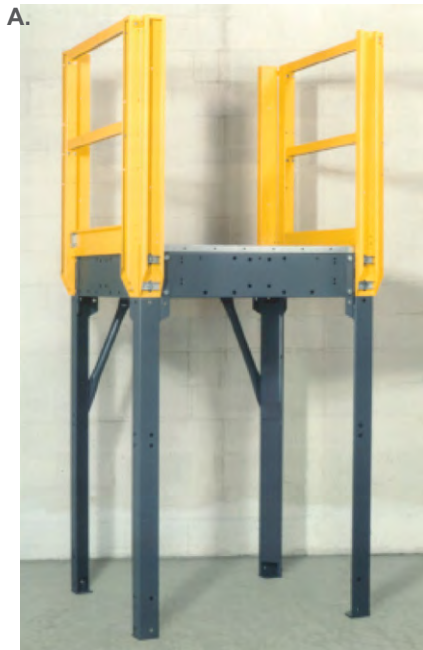

Platform landing is used for straight through passage with stairway proceeding upward.

For a 90° angle, this platform landing configuration assembles either to right or left.

The 180° turn platform is used in tight areas to conserve space.

A standard color chart is available on page 150.

Platforms & Mezzanines

Custom Configured Platforms

Need more space, but don't want to move or add on?

Double or triple your floor space with Equipto pre-fabricated Platforms!

These rugged elevated floors, walkways and stairways add valuable area where you need it, at a fraction of the cost of acquiring new buildings.

Because of their modular design, Equipto platforms are economical, quickly installed and can even be re-configured on your premises as your requirements change. They are designed to integrate with other Equipto products to provide one-source space savings that are custom tailored for your individual application. Every place from aircraft hangars to warehouses to factories will benefit from the space saving solutions provided with Equipto platforms!

- Double floor capacity
- Modular design lets you add units as needed
- Cost-effective
- Customized solution to the problem of limited space
- Less expensive than leasing or Construction
- Move them within your facility
- Relocation to other facilities is easy
- Prefabricated for immediate use

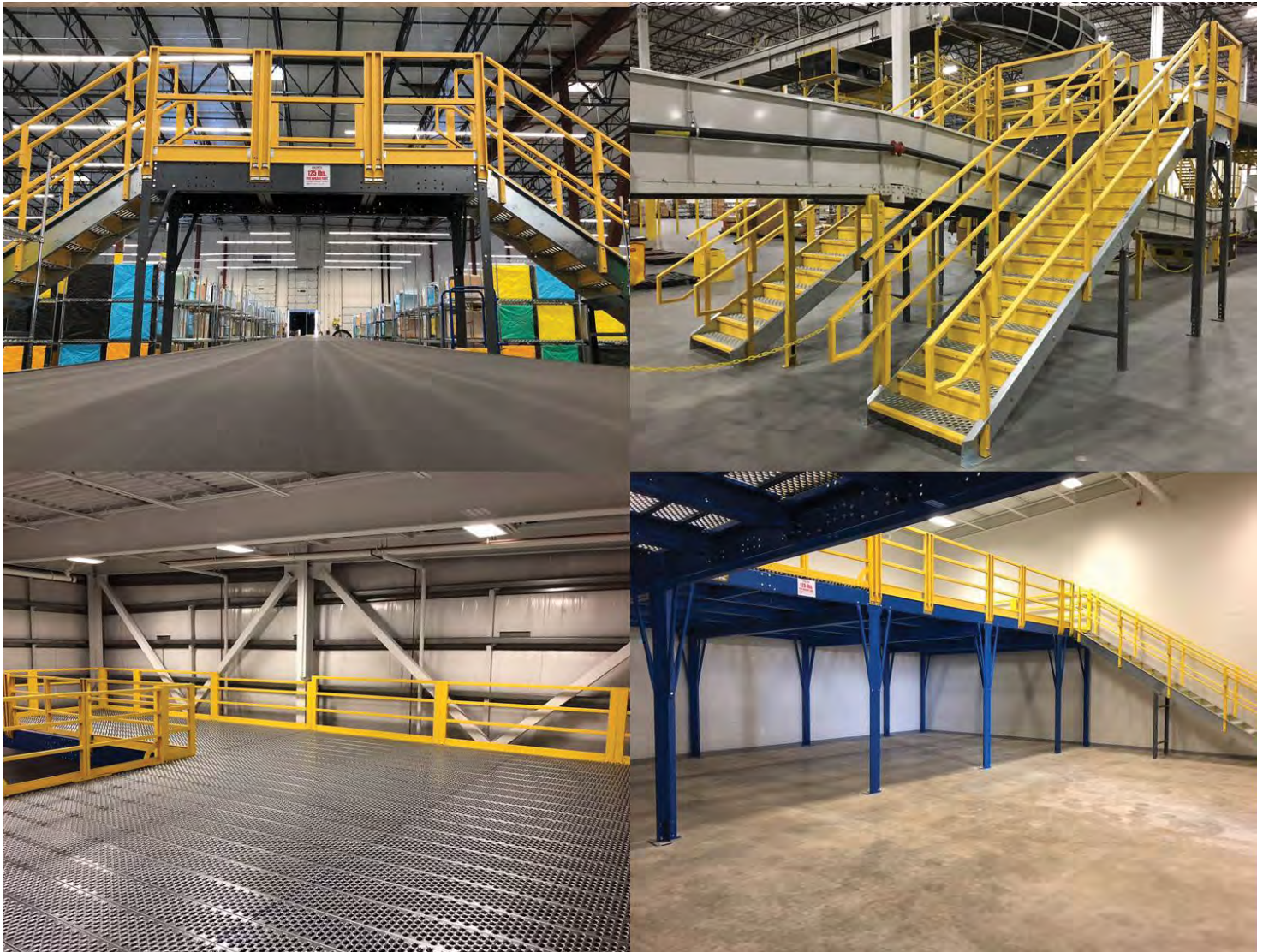

1st - Design your Platform

Select your Platform module

1. Select Platform Module and Flooring.
2. Select Stairways and Platforms.
3. Select Railings, Drop Gates and Accessories.

Sketch and define specifications, then contact Equipto.

Please contact Equipto Inside Sales with a sketch and details of what you need, and we will customize a Platform to fit your needs. Parts list and examples are for reference purposes only.

Seismic code conformity available upon request.

Generation IV Platform Selection Chart - Most Popular Sizes (must add flooring suffix – see below)

		Length →	4'	6'	8'	10'	12'	16'	20'	Platform uprights - triangular	
8' High	Width	4'	480404	480406	480408	480410	480412	480416	480420	4' H	5204
		6'	480604	480606	480608	480610	480612	480616	480620	6' H	5206
		8'	480804	480806	480808	480810	480812	480816	480820	8' H	5208
		10'	481004	481006	481008	481010	481012	481016	481020	9' H	5209
9' High	Width	4'	490404	490406	490408	490410	490412	490416	490420	10' H	5210
		6'	490604	490606	490608	490610	490612	490616	490620	12' H	5212
		8'	490804	490806	490808	490810	490812	490816	490820		
		10'	491004	491006	491008	491010	491012	491016	491020		
10' High	Width	4'	410404	410406	410408	410410	410412	410416	410420		
		6'	410604	410606	410608	410610	410612	410616	410620		
		8'	410804	410806	410808	410810	410812	410816	410820		
		10'	411004	411006	411008	411010	411012	411016	411020		
12' High	Width	4'	420404	420406	420408	420410	420412	420416	420420		
		6'	420604	420606	420608	420610	420612	420616	420620		
		8'	420804	420806	420808	420810	420812	420816	420820		
		10'	421004	421006	421008	421010	421012	421016	421020		

Platform uprights - square

8' H	5218
9' H	5219
10' H	5220
12' H	5222

Note: for seismic and 16' or 20' Width beam corners.

Tubular brace for exterior corners

- 6424 - Use with beams less than 16' long
- 6485 - Use with beams 16' and longer

Custom sizes available upon request.

NOTE: STANDARD LOAD CAPACITY IS 125LBS./SQ.FT. UNIFORMLY DISTRIBUTED (150LBS./SQ.FT. IN SEISMIC ZONE 0).

2nd - Choose Flooring

- 4 types to choose from:
- Choose Platform Module:
 - PG - Perforated Steel Grating
 - SG - Solid Steel Grating
 - LD2 - No Deck, beams on 2' centers*
 - LD4 - No Deck, beams on 4' centers*

Platform Module Part Number + Suffix = Part No. Ex: 490812LD2

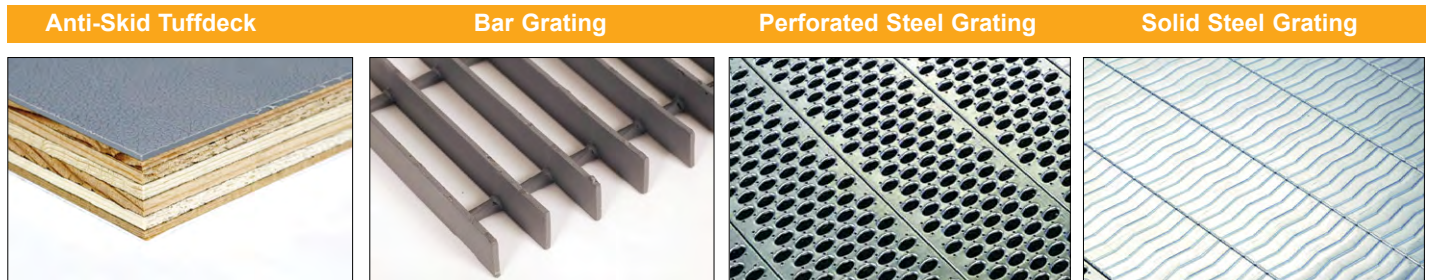

*Platform floor options

With LD2 Modules: No Deck, Beams on 2' centers
Part No. Description

10217 Tuffdeck 4' x 8' x 1 1/8"

With LD4 Modules: No Deck, Beams on 4' centers
Part No. Description

- 10218 Tuffdeck 4' x 8' x 3/4" Use with RFD
- 10248PLY Plywood 4' x 8' x 3/4" Use with RFD
- RFD 1sq. ft. roofdeck (for 3/4" Tuffdeck or Plywood)
- BRG 1sq. ft. bar grating (no subfloor required)

Contact Equipto Inside Sales for fire retardant Tuffdeck.

A standard color chart is available on page 150.

3rd - Add Railings and Drop Gates

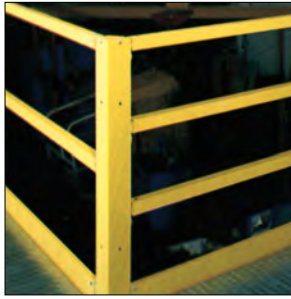

Generation IV Railing and Kick Plate

Rail posts are side-mounted to the platform beams and are available in 2-rail and 3-rail sections of 2', 4', 5', 6' & 8'.

Generation II Railing and Kick Plate

Rail posts (3" x 3") mount to the platform decking surface. Individual rail channels and kick plates are available in lengths of 30", 42", 45", 57", 69", 72", 90" & 93".
(these measurements do not include the posts).



Drop gates

Pivots upward - no floor space needed to operate gate.

Height	Gate Width	Gen IV Part No.	Gen II Part No.
42"	44"	78134G	78134
42"	68"	78136G	78136
42"	88"	78138G	78138

Note: Gate 78138G is made up of two 44" frames.
One opens to each side.

Accessories

Extension posts and stacking brackets

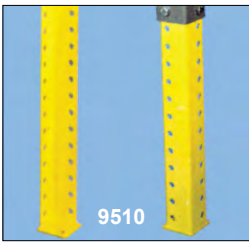

Optional extension posts

Optional Extension Posts (Part No. 9510) permit adjustment of platforms in 2" increments up to 2 feet higher than standard to accommodate tall machines, additional Equipto products, or a sloping floor.
Order with original Platform to ensure that proper posts without footplates are provided. Four required for each Platform module.



Platform stacking bracket

Brackets (4 required) fasten upper and lower posts to permit double-decking of same-size platforms.

Part No. 7720 - 4" x 4" x 3"H

Slotted Angle

Equipto Slotted Angle is the frontrunner in creating steel framing systems. Visualize it, cut it, then bolt it. Build structures to do exactly what you want them to do, with almost no limit to the number of ways it can be assembled.

Capacity (lbs.) per beam length

Configuration	2'	3'	4'	5'	6'	7'	8'	9'	10'
A. Single Pieces Short Legs Down	1139	759	569	455	379	325	284	253	227
B. Single Pieces Long Legs Up	3547	1576	886	568	396	289	222	175	—
C. Single Pieces Long Legs Down	3547	2365	1771	1327	1014	777	587	427	312
D. Narrow Channels	6385	4256	3192	2553	2129	1824	1598	1418	1277
E. T-Beams	7094	4729	3547	2837	2365	2026	1775	1576	1418
F. Broad Channels	10417	6945	5208	4167	3388	2617	2002	1489	1087
G. Broad Channels with Stiffeners	10417	6945	5208	4167	3472	2976	2604	2315	2092
H. J-Beams	15145	10097	7572	6058	5048	4326	3785	3366	2831
I. I-Beams	20835	13890	10416	8334	6945	5952	5208	4629	4166

Note: Capacities in the Table above are for angle used as horizontal beams, in lbs. of distributed load. For load concentrated in center of beam, reduce capacity by 50%. Capacities are per pair of beams; All figures are in lbs. of steady load, with a safety factor of 1.67. For shock or lateral thrust, add braces as needed. Where shown, connecting stiffeners should not be spaced over 3 ft. apart. I-beams and other multiple angles should be bolted together every 12".



Description	Shipping Weight (lbs.)	Part No.
One piece super duty angles 1 1/2" x 3" c x 12 gauge (.104"), 12' long	17.5	5712



Corner gusset

when used as corner brace, this 2" x 7 7/8" gusset adds strength and rigidity to slotted angle units.

Horizontal Capacities

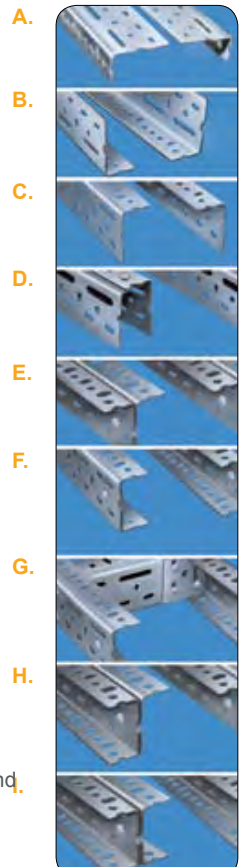

Galvanized steel floor grating

Assures non-skid safety for high load capacities, with minimum deflection. An exceptionally high strength-to-weight ratio makes it suitable for the most demanding jobs with unlimited versatility. Strong, fast to install, and available in sizes appropriate for everything from trench coverings to floors for entire Platform structures.

- Recommended for platforms, catwalks, and multi-level areas
- High strength one-piece channel construction
- Cutting marks are provided on 6" centers to simplify on-the-job measurements and cutting
- Perforated oval hole grating provides raised nubs for 360° traction and safe walking

Part Numbers and stock sizes for Perforated Steel Grating

Width and Flange	Lengths of Panels (Actual Length 1/4" Less Than Shown)							
	24"	30"	36"	48"	72"	96"	120"	144"
7 1/4" x 1 1/2" for 7 1/2" centers	16362	16361	16363	16364	16366	16368	16370	16372
8 3/4" x 1 1/2" for 9" centers	16162	16161	16163	16164	16166	16168	16170	16172*
11 7/8" x 1 1/2" for 12" centers	16142*	16141*	16143*	16144*	16146*	16148*	16150*	16152*

* For solid grating in these sizes only, add SG to Catalog No.



Grating Splicer (pair)

Splicers connect two grating panels end-to-end, without having ends over supports.

Part No. 9549-2

Grating Anchor (close-up shown on right)

Dish-shaped Anchors permit recessed bolt attachment of hanging lights, etc., to decking.

Part No. 10315

Bolt and Nut are required for each grating anchor

Part No. 13194 (5/16" x 2" bolt)



Platforms & Mezzanines

Stair treads

For interior or exterior use, Equipto perforated grating stair treads provide sure traction and maximum rigidity. Exclusive, non-skid treads with 1 1/2" flange are self-cleaning and virtually maintenance free. Galvanized construction provides lasting, corrosion-resistant wear.

Width	Length	Height	Part No.
7 1/4"	24"	1 1/2"	16362WS
7 1/4"	30"	1 1/2"	16361WS
7 1/4"	36"	1 1/2"	16363WS
7 1/4"	48"	1 1/2"	16364WS
8 3/4"	24"	1 1/2"	16162WS
8 3/4"	30"	1 1/2"	16161WS
8 3/4"	36"	1 1/2"	16163WS
8 3/4"	48"	1 1/2"	16164WS
11 7/8"	24"	1 1/2"	16142WS
11 7/8"	30"	1 1/2"	16141WS
11 7/8"	36"	1 1/2"	16143WS
11 7/8"	48"	1 1/2"	16144WS

Stair Treads



16362WS

16162WS



Angle Cutter - 10213

Equipto angle cutter

One stroke makes a clean cut. Strong enough to make thousands of cuts through both Heavy and Super Duty angle. Top Blade Part No. 2711, Lower Blade Part No. 2710.

A standard color chart is available on page 150.

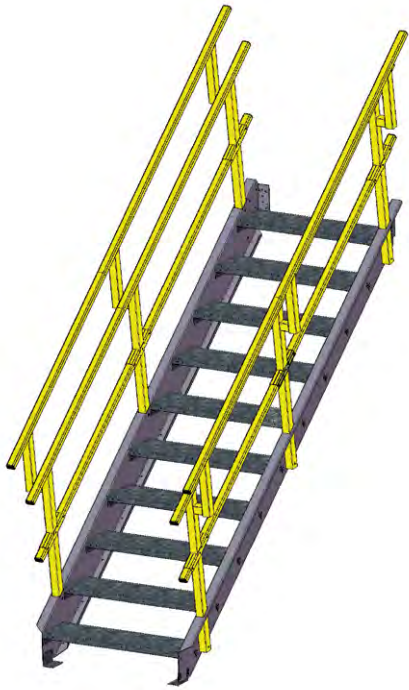

Stairways & Crosswalks

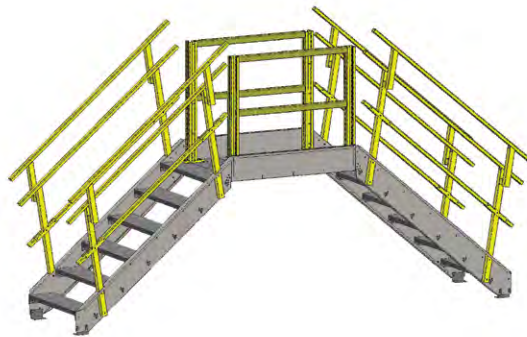

Crossovers, Stairways & Crosswalks

New OSHA & IBC Compliant Ship's Stairways

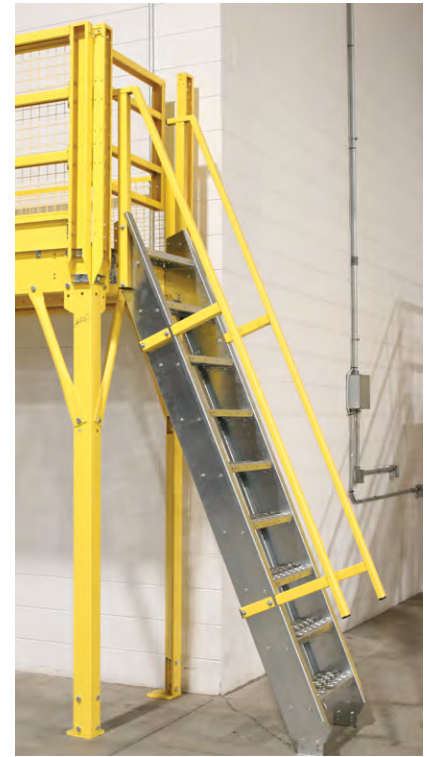

Stairways & Crosswalks

Now Offering Two OSHA Compliant Stairway Designs!

- Over 200 sizes designed to meet or exceed OSHA or IBC standards
- Galvanized steel stairway systems for safe, convenient access to all levels
- Savings to you in time and money
- Completely prefabricated for quick assembly
- One-third the cost of building your own unit from structural steel
- Adaptable to all types of installations
- Prefabricated for indoor use, permanent or temporary
- Heights from 3' to 12' 3" with four tread widths available
- Non-skid, perforated, galvanized grating
- Stairways are hot dipped galvanized except for railings which come in safety yellow.
- Landing Anchor Bracket supplied – pre-drilled 3" to 4 1/2" for mounting stairways to landings
- Base Anchor Bracket supplied – pre-drilled 3" bracket for mounting stairways at base

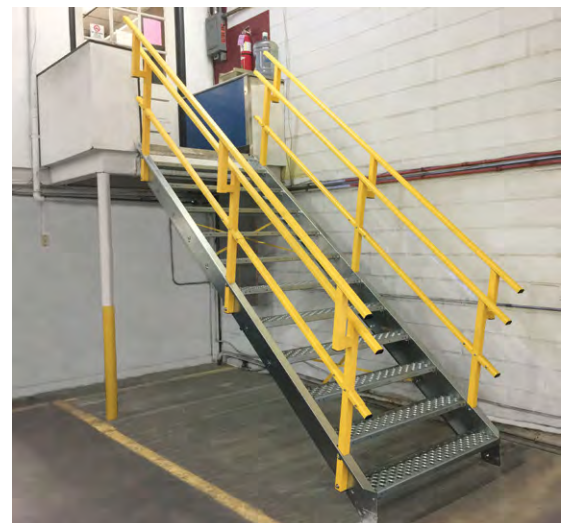

Stairways, Ship's Ladders and Bridges

IBC Stairways (International Building Code)

Rise Min/Max	Run Min/Max	36" Tread Width Part No.	48" Tread Width Part No.
3'0"/3'6"	4'8"/4'11"	1536IBC5	1548IBC5
3'7"/4'0"	5'7"/5'11"	1536IBC6	1548IBC6
4'1"/4'7"	6'6"/6'10"	1536IBC7	1548IBC7
4'8"/5'1"	7'5"/7'10"	1536IBC8	1548IBC8
5'2"/5'10"	8'4"/8'10"	1536IBC9	1548IBC9
6'0"/7'0"	10'1"/10'9"	1536IBC11	1548IBC11
7'1"/8'2"	12'0"/12'9"	1536IBC13	1548IBC13
8'3"/9'4"	13'10"/14'6"	1536IBC15	1548IBC15
9'5"/10'6"	15'8"/16'4"	1536IBC17	1548IBC17
10'7"/12'3"	18'5"/19'4"	1536IBC20	1548IBC20



Stair tread solid panels:

(to close vertical rise)
Riser covers for IBC stairways are included in the above preconfigured units.

(Order one per stair tread)

36" 1536URC-M

48" 1548URC-M

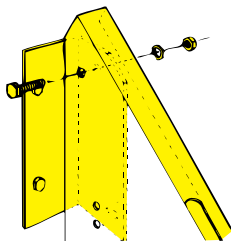

Landing Anchor Bracket (Supplied)

Pre-drilled, 3" to 4 1/2", for mounting stairways to landings.

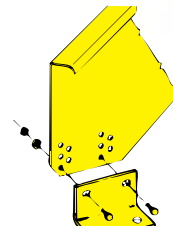

Base Anchor Bracket (Supplied)

Pre-drilled, 3" bracket for mounting stairways at base.

Stairways & Crosswalks

2017 OSHA Series Stairways with External Handrails

Rise Min/Max	Run Min/Max	24" Tread Width Part No.	30" Tread Width Part No.	36" Tread Width Part No.	48" Tread Width Part No.
3'2"/3'8"	3'3"/3'7"	1724S04	1730S04	1736S04	1748S04
3'11"/4'5"	4'0"/4'5"	1724S05	1730S05	1736S05	1748S05
4'6"/5'1"	5'0"/5'4"	1724S06	1730S06	1736S06	1748S06
5'2"/5'9"	5'9"/6'3"	1724S07	1730S07	1736S07	1748S07
5'10"/6'6"	6'7"/7'1"	1724S08	1730S08	1736S08	1748S08
6'7"/7'2"	7'6"/7'11"	1724S09	1730S09	1736S09	1748S09
7'3"/7'11"	8'3"/8'9"	1724S10	1730S10	1736S10	1748S10
8'0"/8'8"	9'1"/9'7"	1724S11	1730S11	1736S11	1748S11
8'9"/9'5"	9'11"/10'5"	1724S12	1730S12	1736S12	1748S12
9'6"/10'10"	11'7"/12'6"	1724S14	1730S14	1736S14	1748S14
10'11"/12'2"	13'0"/14'3"	1724S16	1730S16	1736S16	1748S16

Overall width of stairway is 12 1/2" greater than tread width.

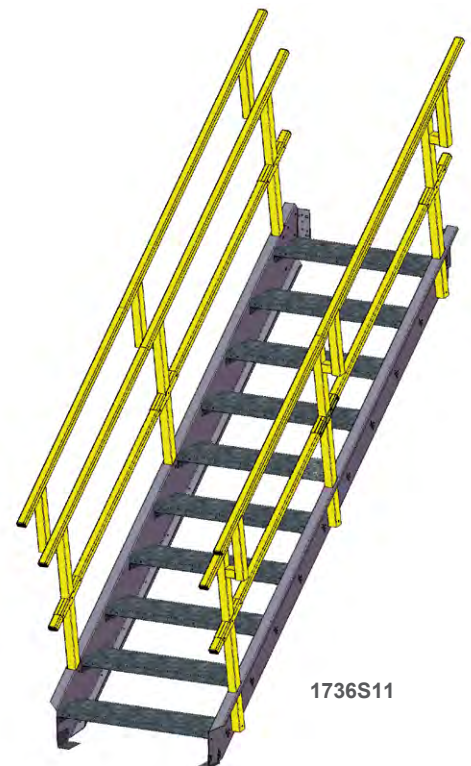

Stairways, Ship's Ladders and Bridges

2017 OSHA Series Stairways with External Handrails



2018 OSHA Series Stairways with Internal Handrails



2018 OSHA Series Stairways with Internal Handrails

Rise	Run	36" Tread	48" Tread
Min/Max	Min/Max	Width	Width
		Part No.	Part No.
3'2"/3'8"	3'3"/3'7"	1836S04	1848S04
3'11"/4'5"	4'0"/4'5"	1836S05	1848S05
4'6"/5'1"	5'0"/5'4"	1836S06	1848S06
5'2"/5'9"	5'9"/6'3"	1836S07	1848S07
5'10"/6'6"	6'7"/7'1"	1836S08	1848S08
6'7"/7'2"	7'6"/7'11"	1836S09	1848S09
7'3"/7'11"	8'3"/8'9"	1836S10	1848S10
8'0"/8'8"	9'1"/9'7"	1836S11	1848S11
8'9"/9'5"	9'11"/10'5"	1836S12	1848S12
9'6"/10'10"	11'7"/12'6"	1836S14	1848S14
10'11"/12'2"	13'0"/14'3"	1836S16	1848S16

Overall width of stairway is 5" greater than the tread width.

Please Note: Internal hand rails are not available on 24" and 30" wide stairways.



Stairways & Crosswalks

Stair tread solid panels to close vertical rise:

(Order one per stair tread)

- 30" 1730SRC
- 36" 1736SRC
- 48" 1748SRC

Ship's Stairways

Equipto's Ship's Stairways provide excellent platform access in a smaller footprint than stairways with a traditional handrail.

- 66°–70° rise
- Deep, non-skid treads
- Handrail
- Designs to meet OSHA or IBC standards



OSHA Ship's Stairways

Rise Max/Min	Run Min/Max	Number of Treads	Part No. 24" Tread	Part No. 30" Tread
43.032"/39.032"	26.08"/26.81"	4	2124OS04	2130OS04
47.156"/43.032"	25.88"/26.64"	4	2124OS04-2	2130OS04-2
50.656"/47.156"	30.55"/31.32"	5	2124OS05	2130OS05
55.032"/50.656"	29.81"/31.28"	5	2124OS05-2	2130OS05-2
59.531"/55.032"	29.84"/31.33"	5	2124OS05-3	2130OS05-3
63.953"/59.532"	34.60"/36.47"	6	2124OS06	2130OS06
68.656"/63.953"	33.98"/36.18"	6	2124OS06-2	2130OS06-2
73.094"/68.656"	38.97"/41.07"	7	2124OS07	2130OS07
78.032"/73.094"	38.31"/41.27"	7	2124OS07-2	2130OS07-2
83.125"/78.032"	38.25"/41.21"	7	2124OS07-3	2130OS07-3
88.375"/83.125"	41.82"/45.40"	8	2124OS08	2130OS08
93.750"/88.375"	44.19"/45.36"	8	2124OS08-2	2130OS08-2
99.250"/93.750"	46.24"/50.62"	9	2124OS09	2130OS09
104.906"/99.250"	46.28"/50.67"	9	2124OS09-2	2130OS09-2
110.719"/104.906"	50.31"/55.40"	10	2124OS10	2130OS10
116.656"/110.719"	50.31"/55.40"	10	2124OS10-2	2130OS10-2
122.750"/116.656"	54.11"/59.88"	11	2124OS11	2130OS11
129.000"/122.750"	54.13"/59.91"	11	2124OS11-2	2130OS11-2
135.438"/129.000"	58.19"/64.67"	12	2124OS12	2130OS12



OSHA-compliant
2124OS09

IBC Ship's Stairways

Rise Max/Min	Run Min/Max	Number of Treads	Part No. 24" Tread	Part No. 30" Tread
44.826"/40.610"	39.25"/40.34"	5	2124IBC05-2	2130IBC05-2
47.030"/42.550"	31.87"/32.22"	5	2124IBC05	2130IBC05
52.016"/47.403"	40.55"/41.50"	6	2124IBC06-3	2130IBC06-3
53.590"/58.983"	39.25"/40.34"	6	2124IBC06-2	2130IBC06-2
56.478"/51.625"	43.43"/45.28"	6	2124IBC06	2130IBC06
60.497"/55.493"	45.88"/47.43"	7	2124IBC07-3	2130IBC07-3
62.355"/57.356"	44.92"/46.72"	7	2124IBC07-2	2130IBC07-2
65.925"/60.698"	48.90"/51.45"	7	2124IBC07	2130IBC07
71.117"/65.729"	57.28"/60.62"	8	2124IBC08-2	2130IBC08-2
75.373"/69.772"	56.92"/53.74"	8	2124IBC08	2130IBC08
79.884"/74.103"	57.28"/60.62"	9	2124IBC09-2	2130IBC09-2
84.820"/78.846"	59.83"/63.80"	9	2124IBC09	2130IBC09
88.648"/82.476"	64.40"/66.38"	10	2124IBC10-2	2130IBC10-2
94.268"/87.920"	65.92"/70.67"	10	2124IBC10	2130IBC10
97.412"/90.849"	69.51"/74.39"	11	2124IBC11-2	2130IBC11-2
103.715"/96.995"	65.92"/70.67"	11	2124IBC11	2130IBC11
106.177"/99.223"	75.30"/80.90"	12	2124IBC12-2	2130IBC12-2
113.163"/106.069"	71.39"/76.84"	12	2124IBC12	2130IBC12
114.941"/107.596"	75.30"/90.90"	13	2124IBC13-2	2130IBC13-2
122.610"/115.143"	76.86"/83.02"	13	2124IBC13	2130IBC13



IBC-compliant
2124IBC09

Other stairway designs are available — ask your customer service representative.



Ship's Ladders

Equipto's Ship's Ladders provide safe, multi-level access up or down to platforms, roofs, platforms, pits, trenches and wells. Extended hand rails and non-skid treads provide added safety.

- Ship's ladders meet OSHA standards
- New hand rail design
- Ideal where space is at a premium
- Deep, non-skid treads provide firm footing
- Wide hand rails (2^{1/2}") extend 42" above top stair tread
- Coordinate with many other Equipto products
- 75° rise

*Note: The actual floor height is dependent on material being used for the flooring of the platform/landing. Add the following to "Flooring support height" for:

- Bar grating - 1"
- Perforated/solid grating - 1^{1/2}"
- Tuffdeck - 1^{1/8}"
- Tuffdeck & roofdeck - 2^{1/4}"

Ship's Ladders

For Floor Heights of:*	Horiz. Run	Tread Width	Overall Width	Part No.
3'8" to 4'7 ^{1/2} "	1'11"	24"	29"	1524L04
4'7 ^{1/2} " to 5'7"	1'11"	30"	35"	1530L04
5'7" to 6'6"	2'2"	24"	29"	1524L05
6'6" to 7'6"	2'2"	30"	35"	1530L05
7'6" to 8'6"	2'5"	24"	29"	1524L06
8'6" to 9'5"	2'5"	30"	35"	1530L06
9'5" to 10'5"	2'8"	24"	29"	1524L07
10'5" to 11'5"	2'8"	30"	35"	1530L07
	2'11"	24"	29"	1524L08
	2'11"	30"	35"	1530L08
	3'2"	24"	29"	1524L09
	3'2"	30"	35"	1530L09
	3'5"	24"	29"	1524L10
	3'5"	30"	35"	1530L10
	3'8"	24"	29"	1524L11
	3'8"	30"	35"	1530L11



Rise from tread to tread – approx. 11^{1/2}".
The tread is 1^{1/2}" in height.
The opening is about 10".
(space between steps)

Crossover Bridges

Prefabricated crossover bridges provide safe walkways over conveyors, ducts, pipes and other obstacles. Use them for observation platforms - in plants or out in the field.

- Ready-made for fast assembly, no cutting or welding
- Galvanized, non-skid steps and platform
- Designed to meet OSHA standards
- Distributed load capacity of 125 lbs. per square foot
- 24" Stair Tread for Crossover Bridge does not meet OSHA standards

Ship's Ladder Crossover Bridges

A Vertical Clearance	B Length at 36" Height	C Overall Height	D Overall Length	Part No. 24" Tread Width	Part No. 30" Tread Width
42"	34"	7'2"	5'9"	1524X04	1530X04
54"	40"	8'1"	6'3"	1524X05	1530X05
65"	46"	9'1"	6'10"	1524X06	1530X06
77"	52"	10'1"	7'4"	1524X07	1530X07
88"	59"	11'0"	7'10"	1524X08	1530X08
100"	65"	12'0"	8'4"	1524X09	1530X09
112"	71"	12'11"	8'10"	1524X10	1530X10
123"	77"	13'11"	9'5"	1524X11	1530X11

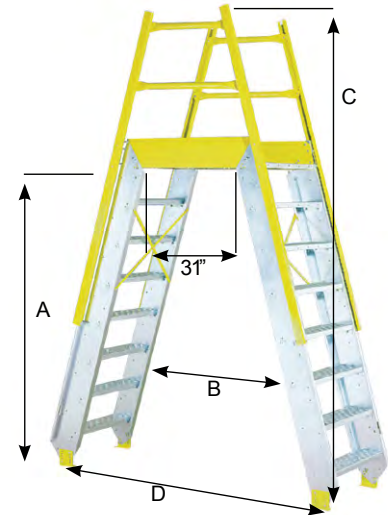

Ship's Ladder Crossover Bridge

Stair Crossover Bridges

A Vertical Clearance	B Length at 36" Height	C Overall Height	D Overall Length	Part No. 24" Stair Tread is 36 ^{1/2} " Overall	Part No. 30" Stair Tread is 42 ^{1/2} " Overall	Part No. 36" Stair Tread is 48 ^{1/2} " Overall
2'8 ^{1/4} "	—	6'4"	10'8"	1724B04	1730B04	1736B04
3'4 ^{3/4} "	4'6 ^{5/32} "	7'0 ^{5/8} "	12'4"	1724B05	1730B05	1736B05
4'1 ^{1/4} "	6'2 ^{1/2} "	7'9 ^{1/8} "	14'0"	1724B06	1730B06	1736B06
4'9 ^{11/16} "	7'10 ^{23/32} "	8'5 ^{5/8} "	15'9"	1724B07	1730B07	1736B07
5'6 ^{9/16} "	9'6 ^{29/32} "	9'2 ^{1/8} "	17'5"	1724B08	1730B08	1736B08
6'2 ^{5/8} "	11'3 ^{1/8} "	9'10 ^{9/16} "	19'1"	1724B09	1730B09	1736B09
6'11 ^{5/32} "	12'11 ^{5/16} "	10'6 ^{3/4} "	20'9"	1724B10	1730B10	1736B10
7'7 ^{5/8} "	14'7 ^{17/32} "	11'3 ^{1/4} "	22'5"	1724B11	1730B11	1736B11

Items on this page hot dip galvanized except railings, which are safety yellow.

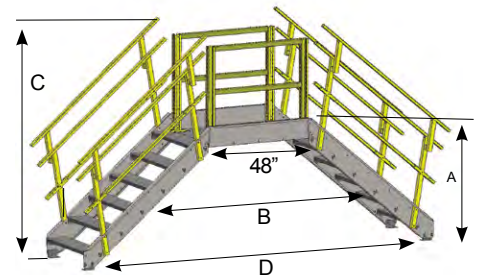

Stair Crossover Bridge

Other stairway designs are available — ask your customer service representative.

Pre-configured Platforms

Need more space, but don't want to move or add on?

Double or triple your floor space with Equipto pre-fabricated platforms! These rugged elevated floors, walkways and stairways add valuable area where you need it, at a fraction of the cost of acquiring new buildings. Because of their modular design, Equipto platforms are economical, quickly installed and can even be re-configured on your premises as your requirements change.

- Double floor capacity
- Modular design lets you add units as needed
- Less expensive than leasing or Construction
- Relocation to other facilities is easy
- Prefabricated for immediate use
- 36" wide stairway to 4' x 4' landing with OSHA stairs
- 36" wide stairway to 5'W x 4'D landing with IBC stairs

Decking options include:

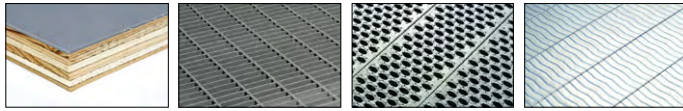

Anti-Skid Tuffdeck

Bar Grating

Perforated Steel Grating

Solid Steel Grating

Rendered image is for visual purposes only. Final product will vary slightly.

They are designed to integrate with other Equipto products to provide one-source space savings that are custom tailored for your individual application. Every place from aircraft hangars to warehouses to factories will benefit from the space saving solutions provided with Equipto platforms!



Photo is a rendered image, the actual product may vary.

Height	Type of Decking	PLATFORM DIMENSIONS (not including stair landing)		
		10'x10'	10'x 20'	8'x12'
OSHA Stairs				
8'	Bar Grating	1010-8GMEZ-BG-17	1020-8GMEZ-BG-17	1208-8GMEZ-BG-17
8'	Perforated Steel Grating	1010-8GMEZ-PG-17	1020-8GMEZ-PG-17	1208-8GMEZ-PG-17
8'	Anti-skid Tuffdeck	1010-8GMEZ-RT-17	1020-8GMEZ-RT-17	1208-8GMEZ-RT-17
8'	Solid Steel Grating	1010-8GMEZ-SG-17	1020-8GMEZ-SG-17	1208-8GMEZ-SG-17
12'	Bar Grating	1010-12GMEZ-BG-17	1020-12GMEZ-BG-17	1208-12GMEZ-BG-17
12'	Perforated Steel Grating	1010-12GMEZ-PG-17	1020-12GMEZ-PG-17	1208-12GMEZ-PG-17
12'	Anti-skid Tuffdeck	1010-12GMEZ-RT-17	1020-12GMEZ-RT-17	1208-12GMEZ-RT-17
12'	Solid Steel Grating	1010-12GMEZ-SG-17	1020-12GMEZ-SG-17	1208-12GMEZ-SG-17

NEW!

IBC Stairs				
8'	Bar Grating	1010-8GMEZ-BG-IBC	1020-8GMEZ-BG-IBC	1208-8GMEZ-BG-IBC
8'	Perforated Steel Grating	1010-8GMEZ-PG-IBC	1020-8GMEZ-PG-IBC	1208-8GMEZ-PG-IBC
8'	Anti-skid Tuffdeck	1010-8GMEZ-RT-IBC	1020-8GMEZ-RT-IBC	1208-8GMEZ-RT-IBC
8'	Solid Steel Grating	1010-8GMEZ-SG-IBC	1020-8GMEZ-SG-IBC	1208-8GMEZ-SG-IBC
12'	Bar Grating	1010-12GMEZ-BG-IBC	1020-12GMEZ-BG-IBC	1208-12GMEZ-BG-IBC
12'	Perforated Steel Grating	1010-12GMEZ-PG-IBC	1020-12GMEZ-PG-IBC	1208-12GMEZ-PG-IBC
12'	Anti-skid Tuffdeck	1010-12GMEZ-RT-IBC	1020-12GMEZ-RT-IBC	1208-12GMEZ-RT-IBC
12'	Solid Steel Grating	1010-12GMEZ-SG-IBC	1020-12GMEZ-SG-IBC	1208-12GMEZ-SG-IBC

Contact your local Equipto Sales Rep to design a custom platform!

Catwalks and Walkways



Ideal for machinery repair, inspection or observation, Equipto Bridge Catwalks can be combined with stairways and ship's ladders to create structures. Versatile, pre-fabricated for easy assembly and engineered for maximum safety and performance.

- Catwalks feature rugged platform frames, 42" high safety railings and 4" high kickplates
- Choose ship's ladders or stairways for access
- 3 pre-configured heights, multiple lengths with add-on units available

Note: Stairways and ship's ladders should be ordered equal to or narrower than catwalk width.

NEW!

OSHA Stairways

Unit Height	Tread Width	Overall Width	Horizontal Stair Run	Stairway Part No.
6'	36"	48 ¹ / ₂ "	6'11"	1836S08
8'	36"	48 ¹ / ₂ "	9'6"	1836S11
10'	36"	48 ¹ / ₂ "	12'0"	1836S14

Ship's Ladders

Unit Height	Tread Width	Overall Width	Horizontal Stair Run	Ladder Part No.
6'	30"	35"	29"	1530L06
8'	30"	35"	35"	1530L08
10'	30"	35"	41"	1530L10

Floor Height	Vertical Clear	Walkway Length	Walkway Width	Catwalk Part No.
6' high unit				
73 ⁵ / ₈ "	63 ¹ / ₂ "	2'	48"	976S02
73 ⁵ / ₈ "	63 ¹ / ₂ "	4'	48"	976S04
73 ⁵ / ₈ "	63 ¹ / ₂ "	6'	48"	976S06
73 ⁵ / ₈ "	63 ¹ / ₂ "	8'	48"	976S08
73 ⁵ / ₈ "	63 ¹ / ₂ "	10'	48"	976S10
73 ⁵ / ₈ "	60 ³ / ₄ "	12'	48"	976S12
73 ⁵ / ₈ "	58"	16'	48"	976S16
73 ⁵ / ₈ "	56"	20'	48"	976S20
8' high unit				
97 ⁵ / ₈ "	87 ¹ / ₂ "	2'	48"	977S02
97 ⁵ / ₈ "	87 ¹ / ₂ "	4'	48"	977S04
97 ⁵ / ₈ "	87 ¹ / ₂ "	6'	48"	977S06
97 ⁵ / ₈ "	87 ¹ / ₂ "	8'	48"	977S08
97 ⁵ / ₈ "	87 ¹ / ₂ "	10'	48"	977S10
97 ⁵ / ₈ "	84 ³ / ₄ "	12'	48"	977S12
97 ⁵ / ₈ "	82"	16'	48"	977S16
97 ⁵ / ₈ "	80"	20'	48"	977S20
10' high unit				
121 ⁵ / ₈ "	111 ¹ / ₂ "	2'	48"	978S02
121 ⁵ / ₈ "	111 ¹ / ₂ "	4'	48"	978S04
121 ⁵ / ₈ "	111 ¹ / ₂ "	6'	48"	978S06
121 ⁵ / ₈ "	111 ¹ / ₂ "	8'	48"	978S08
121 ⁵ / ₈ "	111 ¹ / ₂ "	10'	48"	978S10
121 ⁵ / ₈ "	108 ³ / ₄ "	12'	48"	978S12
121 ⁵ / ₈ "	106"	16'	48"	978S16
121 ⁵ / ₈ "	104"	20'	48"	978S20

Stairways & Crosswalks



Workcenters & Workbenches



NEW!

Preconfigured OmniVerse Workcenter

OmniVerse is an all-in-one work center, versatile enough to allow you to customize to your needs.

The preconfigured workcenters below give you different options all in one part number. If you need any additional accessory, go to the Accessory page to add that item to your workcenter.

All benches come standard with a Hardwood Ash Top & (2) 6-outlet Electrical Rails. Each cabinet comes with (2) 3"H, (1) 4-1/2"H, (1) 6"H & (1) 12" H 200lb drawers. Comes with locks on lower cabinets. Cabinet & Leg can be located on either end.



OmniVerse Workcenter – Preconfigured

Part No.	Description
OV6-CCD-001	6ft Bench w/Overhead light, Lower Shelf, (2) Lower cabinets, (1) Adjustable shelf, (1) Overhead cabinet & (8) 2"H x 4-1/4"W removable drawers
OV4-CLD-001	4ft Bench w/Overhead light, Lower Shelf
OV5-CLD-001	5ft Bench w/Overhead light, Lower Shelf
OV6-CLD-001	6ft Bench w/Overhead light, Lower Shelf (1) Lower cabinet, (1) Leg, (1) Adjustable shelf, (1) Overhead cabinet & (8) 2"H x 4-1/4"W removable drawers

Part No.	Description
OV6-CCD-002	6ft Bench w/Overhead light, Lower Shelf, (2) Lower cabinets, (1) Overhead cabinet, (1) Upper & (1) lower Pegboard back & (1) Lower Solid Back w/ Tack board
OV4-CLD-002	4ft Bench w/Overhead light, Lower Shelf
OV5-CLD-002	5ft Bench w/Overhead light, Lower Shelf
OV6-CLD-002	6ft Bench w/Overhead light, Lower Shelf 1) Lower cabinet, (1) Leg, (1) Overhead cabinet, (1) Upper & (1) lower Pegboard back & (1) Lower Solid Back w/ Tack board

Part No.	Description
OV6-CCD-003	6ft Bench w/Overhead light, Lower Shelf, (2) Lower cabinets, (1) Overhead cabinet, (1) Lower Pegboard back, (1) Upper Solid Back & (1) Lower Solid Back w/ Tack board
OV4-CLD-003	4ft Bench w/Overhead light, Lower Shelf
OV5-CLD-003	5ft Bench w/Overhead light, Lower Shelf
OV6-CLD-003	6ft Bench w/Overhead light, Lower Shelf 2) Lower cabinets, (1) Overhead cabinet, (1) Lower Pegboard back, (1) Upper Solid Back & (1) Lower Solid Back w/ Tack board



OV6-CCD-001



**OV4-CLD-001
OV5-CLD-001
OV6-CLD-001**

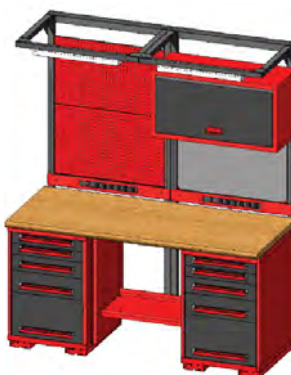

OV6-CCD-002



**OV4-CLD-002
OV5-CLD-002
OV6-CLD-002**



OV6-CCD-003



**OV4-CLD-003
OV5-CLD-003
OV6-CLD-003**

Workcenters & Workbenches

Workcenters & All Accessories will come all in the one color you pick. If you would like items on your bench to be a different color, like pictured above, please contact your rep.

A standard color chart is available on page 150.

OmniVerse Workcenter – Build Your Own!

The Workcenters below all have a Hardwood Ash top that comes with either two cabinets with a lower shelf or one cabinet and a leg with a lower shelf. You can customize your drawer sizes if need be. All units include bracing & lights in the back for overhead lighting and (2) 6-outlet electrical rails above your top.

Head to the accessories to add overhead cabinets, pegboard, tack board, removable drawers, tool holders, spool holders and much more to make your work center function the way you need it to.

NEW!

OmniVerse Cabinet Configurations

Description	4ft Width	5ft Width	6ft Width
Base Cabinet and Closed Leg	OV4-CLD	OV5-CLD	OV6-CLD
Base Model with No Drawers	OV4-CLE	OV5-CLE	OV6-CLE
Two Cabinets	—	—	OV6-CCD
Two Cabinets with No Drawers	—	—	OV6-CCE

OV6-CLD*

30"D X 72"W X 84"H (DESK 35-1/8"H)



OV6-CLE

NO DRAWERS

30"D X 72"W X 84"H (DESK 35-1/8"H)



OV6-CCD*

30"D X 72"W X 84"H (DESK 35-1/8"H)



OV6-CCE

NO DRAWERS

30"D X 72"W X 84"H (DESK 35-1/8"H)



*Each cabinet comes w/ (2) 3"H, (1) 4-1/2"H, (1) 6"H & (1) 12" H 200lb drawers. You can not use a Steel or Stainless Steel (no wood core) top on these benches. Cabinet & Leg can be located on either end. Workcenters & All Accessories will come all in the one color you pick. If you would like items on your bench to be a different color, like pictured above, please contact your rep.

OmniVerse Workcenter Accessories

Workcenters & Workbenches



Drawers (for empty cabinets)

22-1/2" 200 lb. Drawers (95 points to fill cab.)	Description	Points
8623-10	3"H Drawer	10
8624-15	4-1/2"H Drawer	15
8625-20	6"H Drawer	20
8626-25	7-1/2"H Drawer	25
8627-30	9"H Drawer	30
8628-35	10-1/2"H Drawer	35
8629-40	12"H Drawer	40

*For more information on these drawers and for divider kits see page 44.



Overhead Cabinet/Sloped Shelf/Lock

Part No.	Description
AFCAB241518	24"Wx15"Dx18 1/2"H Cabinet/retractable door
AFCAB301518	30"Wx15"Dx18 1/2"H Cabinet/retractable door
AFCAB361518	36"Wx15"Dx18 1/2"H Cabinet/retractable door
AFASHELF2412	12"Dx24"W Adjustable Sloped Shelf
AFASHELF3012	12"Dx30"W Adjustable Sloped Shelf
AFASHELF3612	12"Dx36"W Adjustable Sloped Shelf
AFASHELF12ES	Pair End Stops for sloped shelf
4101	Lock for drawer cabinet

OmniVerse Workcenter Accessories

Tool Accessories

Part No.	Description
AFRAIL24	24"W Tool Rail
AFRAIL30	30"W Tool Rail
AFRAIL36	36"W Tool Rail
AFSPOOL	Spool Holder (need tool rail)
AFTRAY	Tool Tray (need tool rail)



OmniVerse Louvers, Panels, Peg Boards, Tack or Steel Panels

Description	24"	30"	36"
Upper Louver Panel	AFLPU24	AFLPU30	AFLPU36
Lower Louver Panel	AFLPL24	AFLPL30	AFLPL36
Upper Peg Board	AFPEGU24	AFPEGU30	AFPEGU36
Lower Peg Board	AFPEGL24	AFPEGL30	AFPEGL36
Tack Board (Must also order an upper or a lower back panel to attach to)	AFTB24	AFTB30	AFTB36
Upper Metal Back Panel	AFBPU24	AFBPU30	AFBPU36
Lower Metal Back Panel	AFBPL25	AFBPL30	AFBPL36

To close off 1 entire 36"W top section of the upper unit use both an upper and lower panel (pictured on the left hand side), if you have a cabinet on the upper part use 1 lower panel to close it off below it. (pictured on the right hand side, please note you can not use a upper back panel behind the cabinet.) If you close the entire back of the bench on both 36"W sides you need 2 lowers and 2 uppers.

Removable Bins

Part No.	Description	Divider #	Points
2"H Rail			
AFDWRRAIL224	24"W Bin Rail	—	Holds 120
AFDWRRAIL230	30"W Bin Rail	—	Holds 120
AFDWRRAIL2	36"W Bin Rail	—	Holds 120
2"H Bins			
8532	4-1/4"W x 11"D	8732	15
8534	5-5/8"W x 11"D	8734	20
3-1/8"H Rail			
AFDWRRAIL324	24"W Bin Rail	—	Holds 120
AFDWRRAIL330	30"W Bin Rail	—	Holds 120
AFDWRRAIL3	36"W Bin Rail	—	Holds 120
3-1/8"H Bins			
8504	4-1/4"W x 11"D	8709	15
8505	5-5/8"W x 11"D	8720	20
8553	8-3/8"W x 11"D	8753	30
8556	11-1/4"W x 11"D	8756	40

Order the correct height rail with the correct height bins. Each rail can hold up to 120 points of bins, each bin has a point system add them up to fill your rail with a full row of bins.

EquiptoBay Workcenters

Self configured tech bench systems

The EQUIPTO Bay is a modular Workbench system which can be preconfigured in numerous designs according to individual customer requirements.

All features can be used in a single or double bench setup. Please contact Equipto Inside Sales to build your bench today!

Features:

- Versatile Preconfigured Workbench Systems
- Lower Workbench provided with Sliding Doors or Reel Cabinets
- Stainless Steel Counters and Chaseway
- Lockable Double Bank Tool Cabinets
- 200 lb. Drawer Weight Capacity
- Drawers lined with Rubber Protection Mats
- Tool Cart Lockers to Store and Secure Tools
- Tool Carts available with Optional Wheel Locks
- Adaptable to facility space restrictions
- Ease of installation and assembly
- Ability to relocate and modify for expansion
- Modular Design
- Various color options available

Benefits:

- Economical Standard Preconfigured Work Units
- Can be used in service, maintenance or production areas
- Provides a safe and organized work environment (OSHA)
- Ergonomic design
- Green Compliant

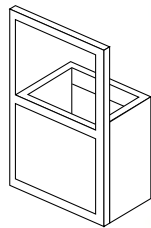

Lower units have 77-1/32"H uprights in the back to hang the upper cabinets on. If no Uppers you can remove the uprights/bracing if you field attach the units to 38"H modular cabinet. Remove the following from the BOM 46081-04EBA, 46081-308 or 46081-306, 46081-307, 46081-308 or 46081-306, 46081-307, 46081-305, 46081-304 and 46081-332 (check BOM of item in JDE for qty and part numbers, units will not have all the above #'s referenced).



Cart fits safe and secure inside locker

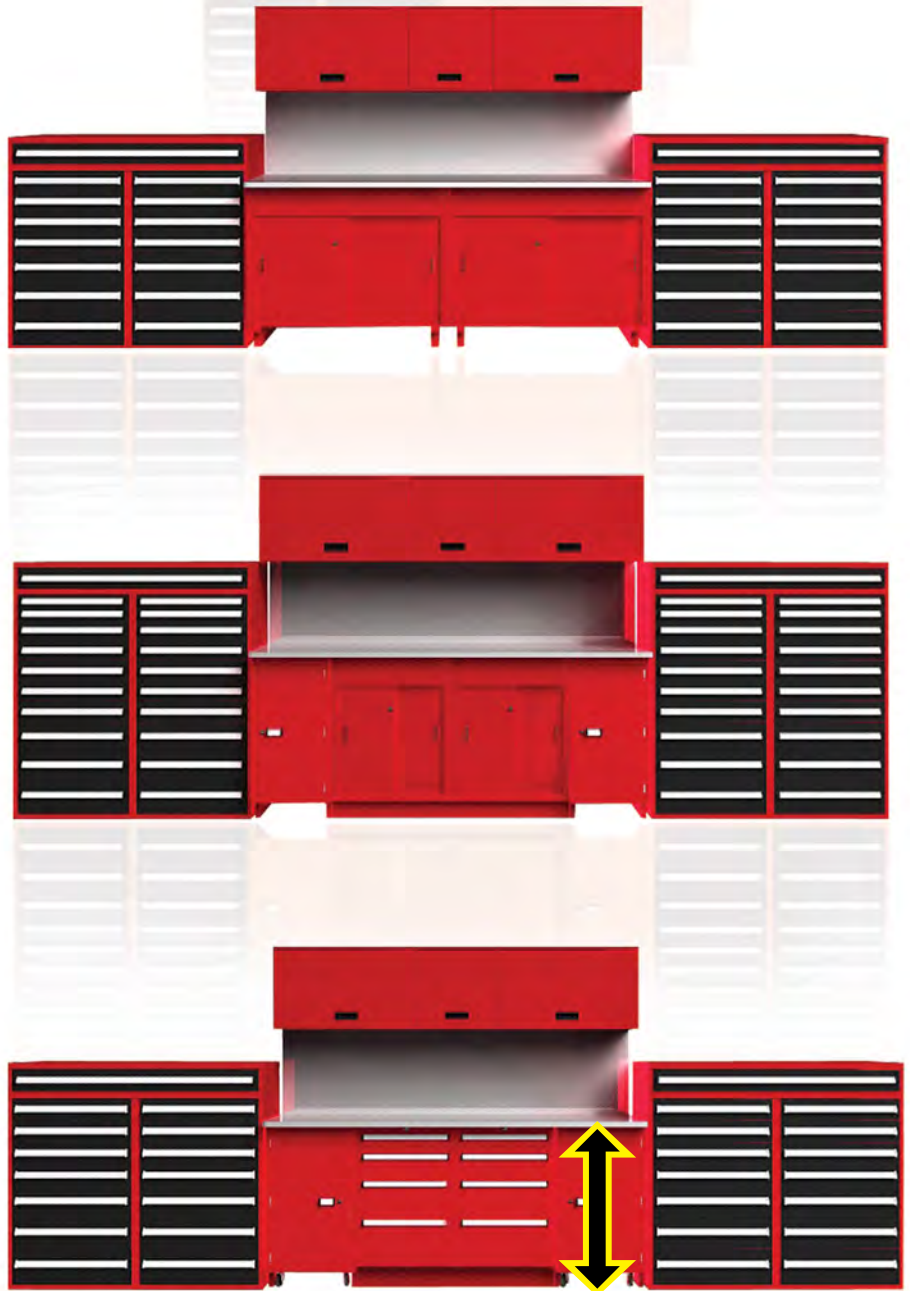

Total height of bench with SS top, 28-3/4"H

A standard color chart is available on page 150.



Lift Control Drawer

Part No.	Available Sizes:
1L1A	12"W x 27 ³ / ₄ "D x 37 ¹ / ₈ "H
2L1A	(2) 12"W x 27 ³ / ₄ "D x 37 ¹ / ₈ "H
1L1B	For RM Motor
2L1B	(2) For RM Motor
1L1C	For Challenger Motor
2L1C	(2) For Challenger Motor
1L1D	For RM3PH Motor
2L1D	(2) For RM3PH Motor
1L1E	For Generic Motor
2L1E	(2) For Generic Motor
1L1F	For ROT600 Motor
2L1F	(2) For ROT600 Motor
1L1G	For Becker Mech Motor
2L1G	(2) For Becker Mech Motor

When ordering, please specify Power Unit Brand and Part Number



Hose Reel Bench Unit

with removable front panel
27³/₄"D x 37¹/₈"H

Part No.	Available Sizes:
1R2	24"W - 2 Hose reels
1R3	36"W - 3 Hose reels
2R3	(2) 36"W - 3 Hose reels
1R4	48"W - 4 Hose reels
2R4	(2) 48"W - 4 Hose reels
1R5	60"W - 5 Hose reels
2R5	(2) 60"W - 5 Hose reels



Service Cart Locker

Service cart included with locker

Part No.	Available Sizes:
1N2	24"W x 27 ³ / ₄ "D x 37 ¹ / ₈ "H
2N2	(2) 24"W x 27 ³ / ₄ "D x 37 ¹ / ₈ "H

EQUIPTO SERVICE CART

Part No.	Available Sizes:
SVC-1	18 ¹ / ₈ "W x 22 ¹ / ₈ "D x 34"H
11621	3" wheel lock for one cart caster



Sliding Door Bench Unit Kick plate cover is not shown, but is included

Part No.	Available Sizes:
1S3	36"W x 27 ³ / ₄ "D x 37 ¹ / ₈ "H
2S3	(2) 36"W x 27 ³ / ₄ "D x 37 ¹ / ₈ "H
1S4	48"W x 27 ³ / ₄ "D x 37 ¹ / ₈ "H
2S4	(2) 48"W x 27 ³ / ₄ "D x 37 ¹ / ₈ "H
1S5	60"W x 27 ³ / ₄ "D x 37 ¹ / ₈ "H
2S5	(2) 60"W x 27 ³ / ₄ "D x 37 ¹ / ₈ "H



Double Bank Tool Cabinet Kick plate cover is not shown, but is included

Drawer Sizes:
44"H X 60" WIDE: 30"W: (4) 3", (6) 4.5", (2) 6", (2) 7.5" AND 60"W: (1) 4.5"
59"H X 60" WIDE: 30"W: (4) 3", (10) 4.5", (4) 6", (2) 7.5" AND 60"W: (1) 4.5"

Part No.	Available Sizes:
EBMDB44-1	60"W x 27 ³ / ₄ "D x 44"H
EBMDB59-1	60"W x 27 ³ / ₄ "D x 59"H



Modular Cabinets

Drawers sizes include: (1)3"H, (1)6"H, (1)7¹/₂"H, (1)12"H

Part No.	Available Sizes:	22 ¹ / ₂ ", 30", and 45"
1M2A	24"W x 27 ³ / ₄ "D x 37 ¹ / ₈ "H	Cabinets used with
2M2A	(2) 24"W x 27 ³ / ₄ "D x 37 ¹ / ₈ "H	Fillers for 24", 36"
1M3A	36"W x 27 ³ / ₄ "D x 37 ¹ / ₈ "H	and 45" Widths
2M3A	(2) 36"W x 27 ³ / ₄ "D x 37 ¹ / ₈ "H	Note: Alternative drawer
1M4A	48"W x 27 ³ / ₄ "D x 37 ¹ / ₈ "H	configurations available
2M4A	(2) 48"W x 27 ³ / ₄ "D x 37 ¹ / ₈ "H	by contacting EQUIPTO.

Stainless Steel Wood Core Top

All tops include matching chaseway – 21¹/₂" H

Part No.	Application:
S5	30"D x 60"W x 1 ⁵ / ₈ " thick: to be used with a 5' bench
S6	30"D x 72"W x 1 ⁵ / ₈ " thick: to be used with 6' bench
S8	30"D x 96"W x 1 ⁵ / ₈ " thick: to be used with 8' bench
S10	30"D x 120"W x 1 ⁵ / ₈ " thick: to be used with 10' bench



Upper Storage Cabinets

Retractable sliding cabinet doors

Part No.	Cabinets Included:
EBUC-3M3	(2)36"W, (1)24"W monitor cabinet w/ retracting keyboard tray
EBUC-4M	(1)48"W, (1)24"W monitor cabinet w/ retracting keyboard tray
EBUC-4M4	(2)48"W, (1)24"W monitor cabinet w/ retracting keyboard tray
EBUC-2M2	(2)24"W, (1)24"W monitor cabinet w/ retracting keyboard tray
EBUC-33	(2)36"W x 15"D x 21"H
EBUC-44	(2)48"W x 15"D x 21"H

Gas Spring lift cabinet doors

Part No.	Cabinets Included:
EBUC-3M3GS	(2)36"W, (1)24"W monitor cabinet w/ retracting keyboard tray
EBUC-33GS	(2)36"W x 15"D x 21"H
EBUC-2M2GS	(2)24"W, (1)24"W monitor cabinet w/ retracting keyboard tray
EBUC-4MGS	(1)48"W, (1)24"W monitor cabinet w/ retracting keyboard tray
EBUC-44GS	(2)48"W x 15"D x 21"H
EBUC-4M4GS	(2)48"W, (1)24"W monitor cabinet w/ retracting keyboard tray

Workbenches & Workbenches

Tech Bench Workcenters

The Equipto Tech Bench combines essential service facility equipment and Hi-tech storage functionality to organize every aspect of a technician's workspace

EQUIPTO TECH BENCH



Concealed reel holder compartments, sliding lift control drawers and retractable cabinet doors provide a professional, streamlined appearance.

Workcenters & Workbenches



Lift Control Drawer

Provides hidden compartment to mount the lift control power unit and easily slides out to provide quick and convenient access for servicing.



Lower Bench Cabinets

Neatly organize and conceal reel holders for air, water and lubricants behind removable sliding cabinet doors. Prevent dirt, trash and debris from collecting and obstructing reel unwinding and rewinding.



Monitor Enclosure

Offers eye-level storage compartment for service computer monitor. Retractable keyboard tray adjusts to individual user level and is center mounted under the monitor enclosure.

A standard color chart is available on page 150.

Tech Bench Workcenters - Preconfigured Units

1st

Select the lower bench unit

Select the sliding door or removable panel lower bench configuration;
Available in 4', 5', 6', 8' and 10' lengths.

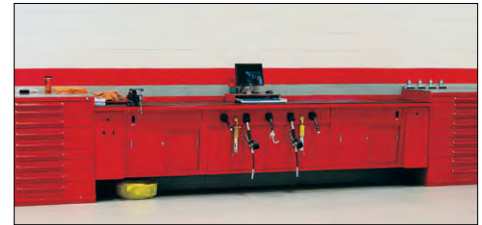

Stainless Steel Top - Preconfigured Units

16 gauge solid steel over wood core, wall-mount workcenter with a one piece top and integral backstop. Cabinets feature sliding/removable doors for storage or servicing of equipment. Includes knockouts for electrical outlets and hoses. (Electrical outlets and hoses not included). Standard cover plates are included, specialty cover plates are listed in the Optional Accessories section on page 99.

Tech bench lower bench cabinets do not include back panel since wall mount is assumed. For free standing kits which include the back panel, see page 99.

Sliding door lower bench wall units (If units will be freestanding add kits on page 99)

Part No.	Description
TBL10S-55DN	Includes two 60" sliding door bench units with a 10' stainless steel top - 120"W x 30"D x 28 ^{3/4} "H
TBL10S-44DE	Includes two 48" sliding door bench units with one 12" overhang on each end with a stainless steel top - 120"W x 30"D x 28 ^{3/4} "H
TBL10S-44DC	Includes two 48" sliding door bench units with one 24" center opening with a stainless steel top - 120"W x 30"D x 28 ^{3/4} "H
TBL8S-44DN	Includes two 48" sliding door bench units with a 8' stainless steel top - 96"W x 30"D x 28 ^{3/4} "H
TBL8S-33DE	Includes two 36" sliding door bench units with one 12" overhang on each end with a stainless steel top - 96"W x 30"D x 28 ^{3/4} "H
TBL6S-5DE	Includes one 60" sliding door bench unit with one 12" overhang with a stainless steel top - 72"W x 30"D x 28 ^{3/4} "H
TBL5S-5DN	Includes one 60" sliding door bench unit with a 5' stainless steel top - 60"W x 30"D x 28 ^{3/4} "H
TBL4S-3DE	Includes one 36" sliding door bench unit with one 12" overhang with a stainless steel top - 48"W x 30"D x 28 ^{3/4} "H

Removable door lower bench wall units

Part No.	Description
TBL10S-55PN	Includes two 60" removable panel bench units with a 10' stainless steel top - 120"W x 30"D x 28 ^{3/4} "H
TBL10S-44PE	Includes two 48" removable panel bench units with one 12" overhang on each end with a stainless steel top - 120"W x 30"D x 28 ^{3/4} "H
TBL10S-44PC	Includes two 48" removable panel bench units with one 24" center opening with a stainless steel top - 120"W x 30"D x 28 ^{3/4} "H
TBL8S-44PN	Includes two 48" removable panel bench units with a 8' stainless steel top - 96"W x 30"D x 28 ^{3/4} "H
TBL8S-33PE	Includes two 36" removable panel bench units with one 12" overhang on each end with a stainless steel top - 96"W x 30"D x 28 ^{3/4} "H
TBL6S-5PE	Includes one 60" removable panel bench unit with one 12" overhang with a stainless steel top - 72"W x 30"D x 28 ^{3/4} "H
TBL5S-5PN	Includes one 60" removable panel bench unit with a 5' stainless steel top - 60"W x 30"D x 28 ^{3/4} "H
TBL4S-3PE	Includes one 36" removable panel bench unit with one 12" overhang with a stainless steel top - 48"W x 30"D x 28 ^{3/4} "H

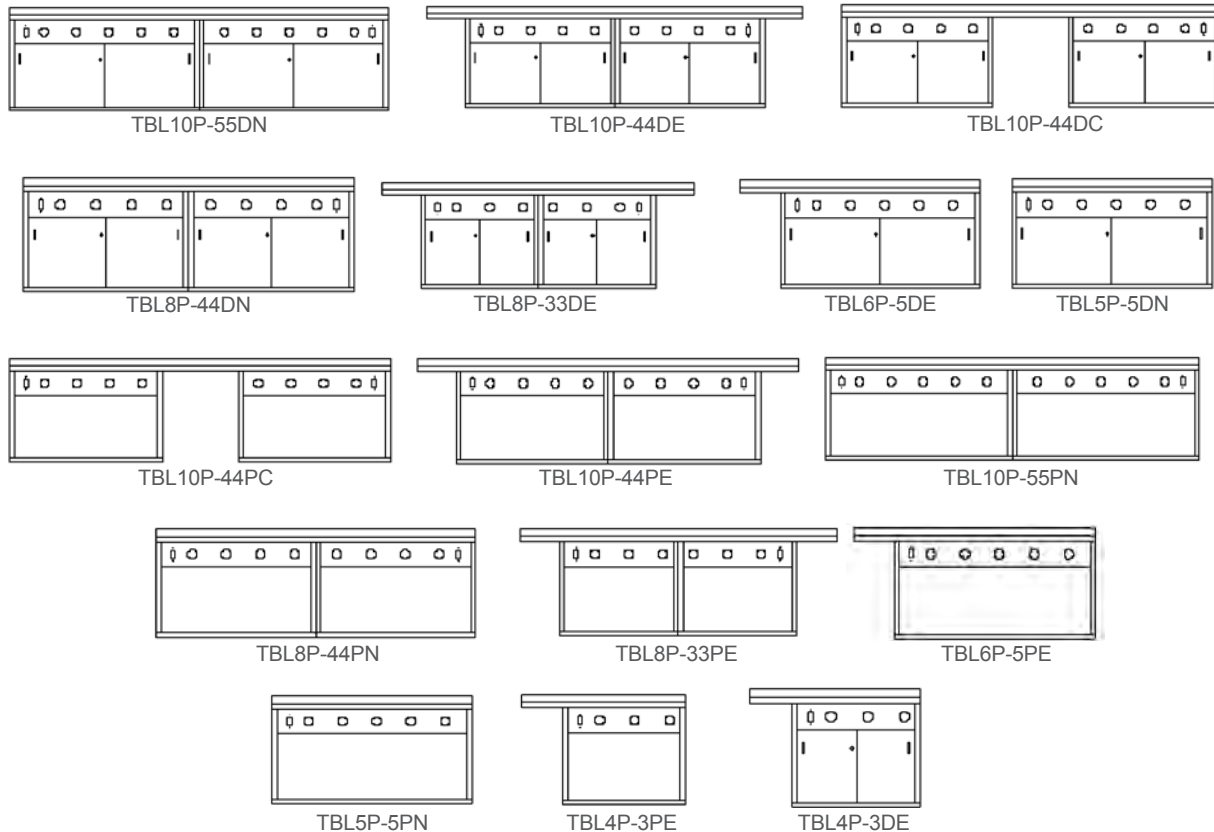

A standard color chart is available on page 150.

Workcenters & Workbenches

Optional Painted Steel Top - Preconfigured units

Painted 16 gauge solid steel over a wood core, wall-mount work center with a one piece top and integral backstop.

Cabinets feature sliding/removable doors for storage or servicing of equipment.

Includes knockouts for electrical outlets and hoses. (Electrical outlets and hoses not included).

Standard cover plates are included, specialty cover plates are listed in the Optional Accessories section on page 99.

Sliding door lower bench units

Part No.	Description
TBL10P-55DN	Includes two 60" sliding door bench units with a 10' painted steel top - 120"W x 30"D x 28 ^{3/4} "H
TBL10P-44DE	Includes two 48" sliding door bench units with one 12" overhang on each end with a painted steel top - 120"W x 30"D x 28 ^{3/4} "H
TBL10P-44DC	Includes two 48" sliding door bench units with one 24" center opening with a painted steel top - 120"W x 30"D x 28 ^{3/4} "H
TBL8P-44DN	Includes two 48" sliding door bench units with a 8' painted steel top - 96"W x 30"D x 28 ^{3/4} "H
TBL8P-33DE	Includes two 36" sliding door bench units with one 12" overhang on each end with a painted steel top - 96"W x 30"D x 28 ^{3/4} "H
TBL6P-5DE	Includes one 60" sliding door bench unit with one 12" overhang with a painted steel top - 72"W x 30"D x 28 ^{3/4} "H
TBL5P-5DN	Includes one 60" sliding door bench unit with a 5' painted steel top - 60"W x 30"D x 28 ^{3/4} "H
TBL4P-3DE	Includes one 36" sliding door bench unit with one 12" overhang with a painted steel top - 48"W x 30"D x 28 ^{3/4} "H

Removable panel lower bench units

Part No.	Description
TBL10P-55PN	Includes two 60" removable panel bench units with a 10' painted steel top - 120"W x 30"D x 28 ^{3/4} "H
TBL10P-44PE	Includes two 48" removable panel bench units with one 12" overhang on each end with a painted steel top - 120"W x 30"D x 28 ^{3/4} "H
TBL10P-44PC	Includes two 48" removable panel bench units with one 24" center opening with a painted steel top - 120"W x 30"D x 28 ^{3/4} "H
TBL8P-44PN	Includes two 48" removable panel bench units with a 8' painted steel top - 96"W x 30"D x 28 ^{3/4} "H
TBL8P-33PE	Includes two 36" removable panel bench units with one 12" overhang on each end with a painted steel top - 96"W x 30"D x 28 ^{3/4} "H
TBL6P-5PE	Includes one 60" removable panel bench unit with one 12" overhang with a painted steel top - 72"W x 30"D x 28 ^{3/4} "H
TBL5P-5PN	Includes one 60" removable panel bench unit with a 5' painted steel top - 60"W x 30"D x 28 ^{3/4} "H
TBL4P-3PE	Includes one 36" removable panel bench unit with one 12" overhang with a painted steel top - 48"W x 30"D x 28 ^{3/4} "H

examples shown on previous page

Tech Bench Workcenter - Preconfigured Units

2nd

Select the upper cabinet unit

Available in 4', 5', 6', 8' and 10' lengths.

Wall-mount cabinet unit with your choice of retractable sliding cabinet and/or gas shock door, and one 24" monitor enclosure with retracting keyboard tray.

Part No.	Description
TBU10-4M4	Includes two 48" storage cabinets and one 24" monitor cabinet - 120"W x 15"D x 21"H
TBU8-3M3	Includes two 36" storage cabinets and one 24" monitor cabinet - 96"W x 15"D x 21"H
TBU6-M4	Includes one 48" storage cabinet and one 24" monitor cabinet - 72"W x 15"D x 21"H
TBU5-M3	Includes one 36" storage cabinet and one 24" monitor cabinet - 60"W x 15"D x 21"H
TBU4-M2	Includes one 24" storage cabinet and one 24" monitor cabinet - 48"W x 15"D x 21"H
TBU-SMK-16	Bracket to mount to 16 ^{1/2} " deep Aerial Shelf, comes in pairs, need 1 pair per aerial
TBU-SMK-13	Bracket to mount to 13 ^{1/2} " deep Aerial Shelf, comes in pairs, need 1 pair per aerial

For **GAS SHOCK** attachment, "GS" is added to the end of the base upper cabinet part number.

If you would like to have multiple door options, please contact Equipto Inside Sales for a customized quote.

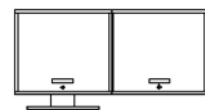

TBU4-M2

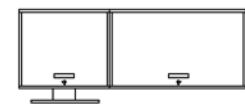

TBU5-M3



TBU6-M4

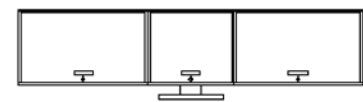

TBU8-3M3

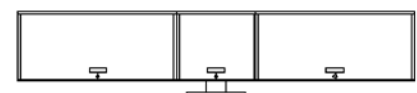

TBU10-4M4



A standard color chart is available on page 150.

Back Braces - for wall mount units only

Uni-strut or equivalent structural channels and appropriate hardware are required to hang upper and lower cabinets from wall and are not provided. **Back braces are required on lower cabinets for wall hanging only.**

Part No.	Description
TBWMK-2	size of brace - 24"
TBWMK-3	size of brace - 36"
TBWMK-4	size of brace - 48"
TBWMK-5	size of brace - 60"

Free-standing kits

(Attach together with post)

Part No.	Description
TBFSK-2	Free Standing Kit - 24"
TBFSK-3	Free Standing Kit - 36"
TBFSK-4	Free Standing Kit - 48"
TBFSK-5	Free Standing Kit - 60"

For lower units only

(Attach separately)

Part No.	Description
TBFSK-2L	Free Standing Kit - 24"
TBFSK-3L	Free Standing Kit - 36"
TBFSK-4L	Free Standing Kit - 48"
TBFSK-5L	Free Standing Kit - 60"



Tech Bench Workcenter - Accessories

Select desired accessories. For additional lift control drawer options, contact Equipto Inside Sales.

Optional Accessories

Part No.	Description
Contact Equipto Inside Sales reps for proper lift control parts	
TBCW-2 (S*)	Painted Steel Chaseway - 24"W
TBCW-3 (S*)	Painted Steel Chaseway - 36"W
TBCW-4 (S*)	Painted Steel Chaseway - 48"W
TBCW-5 (S*)	Painted Steel Chaseway - 60"W
TBCW-6 (S*)	Painted Steel Chaseway - 72"W
TBCW-8 (S*)	Painted Steel Chaseway - 96"W
TBCW-10 (S*)	Painted Steel Chaseway - 120"W

*Add "S" to end of PN for Stainless Steel Chaseway

*Add "H" for pegboard holes

Backsplash less out back stop

Part No.	Description
TBRM-3	Rubber Mat - 36"W
TBRM-4	Rubber Mat - 48"
TBRM-5	Rubber Mat - 60"
TBRM-6	Rubber Mat - 72"
TBRM-8	Rubber Mat - 96"
TBRM-10	Rubber Mat - 120"
TBRK	4 pc. Hose Roller Kit
TBCP-NE	Cover Plate (No Electric) – unpainted
TBCP-WE	Cover Plate (With Electric) – unpainted
TBCP-LR	Cover Plate For Light Reel – unpainted
TBCP-RK	Standard Cover Plate
TBLHS-2	Lower Half Shelf - 24"
TBLHS-3	Lower Half Shelf - 36"
TBLHS-4	Lower Half Shelf - 48"
TBLHS-5	Lower Half Shelf - 60"
TBTER-30S	End Rail - 29 1/32" x 4 1/8" x 1 5/8"
13106M	Key master

*Customer to provide mounting hardware

Tech Bench Workcenter - Modular Components

Upper cabinet components

Part No.	Description
TBU-2	Upper Cabinet - 24"
TBU-M	Upper Monitor Cabinet - 24" (Add QV at end for quick view door)
TBU-3	Upper Cabinet - 36"
TBU-4	Upper Cabinet - 48"
TBU-2GS	Upper Cabinet w/ gas shocks - 24"
TBU-MGS	Upper Monitor Cabinet w/ gas shocks - 24"
TBU-3GS	Upper Cabinet w/ gas shocks - 36"
TBU-4GS	Upper Cabinet w/ gas shocks - 48"

Note: Upper Cabinet Units have an 18" high clearance when the cabinet doors are retracted.

Upper cabinets Quick View – TBU – MQV



Lower cabinet components

Part No.	Description
TBL-2P	With Removable Panel - 24"
TBL-3P	With Removable Panel - 36"
TBL-4P	With Removable Panel - 48"
TBL-5P	With Removable Panel - 60"
TBL-3D	With Sliding Doors - 36"
TBL-4D	With Sliding Doors - 48"
TBL-5D	With Sliding Doors - 60"
TBL-6D	With Sliding Doors - 72"
TBLCD-SC	Side Cover for Lift Control Drawer

Note: Lower bench top not included.

Lower bench tops steel/wood core

Part No.	Description
TBT-3P	Painted Steel Top - 36"
TBT-4P	Painted Steel Top - 48"
TBT-5P	Painted Steel Top - 60"
TBT-6P	Painted Steel Top - 72"
TBT-8P	Painted Steel Top - 96"
TBT-10P	Painted Steel Top - 120"
TBT-3S	Stainless Steel Top - 36"
TBT-4S	Stainless Steel Top - 48"
TBT-5S	Stainless Steel Top - 60"
TBT-6S	Stainless Steel Top - 72"
TBT-8S	Stainless Steel Top - 96"
TBT-10S	Stainless Steel Top - 120"

Note: Lower Bench Tops have a rear overhang of 1 1/4" and a front overhang of 4 1/2".

Lower Cabinets

Panel Front



Sliding Door Front

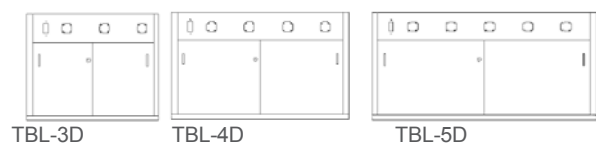

A standard color chart is available on page 150.

Modular Drawer Cabinet Workcenters

Optimize work areas by combining work and storage space into a modular drawer cabinet workcenter. With capacity up to 400 lbs per drawer, and single or double cabinet configurations, these workcenters are designed to last a lifetime.

Modular Drawer Cabinet Workcenter - Preconfigured Units

No dividers – No lock

- All workcenters are 30" deep
- 22¹/₂" wide cabinets feature "Quiet Ride™" Drawers with 200 lb. capacity per drawer
- 30" wide cabinets with 400 lb. capacity per drawer
- Choice of Equipto vivid colors to enhance work environment
- Knockouts in legs provide for safe, convenient electrical hookup
- Lower recessed shelf
- 140 sizes and styles
- Design Efficient workcenters to fit your specific needs
- Choice of 6 tops available in 3 lengths
- Choice of 3 pedestals



Height	Cabinet Model No.	Length	Steel With Backstop	Wood Top Hardwood	Wood Top Bonded Wood	Hardboard With Backstop	ESD Anti-Static
22¹/₂" W Cabinets							
34"	4273	5'	2578U5	2578-5W	2578-5B	2578U5M	2578-5C
		6'	2578U6	2578-6W	2578-6B	2578U6M	2578-6C
		8'	2578U8	2578-8W	2578-8B	2578U8M	2578-8C
29 ¹ / ₂ "	4263	5'	2563U5	2563-5W	2563-5B	2563U5M	2563-5C
		6'	2563U6	2563-6W	2563-6B	2563U6M	2563-6C
		8'	2563U8	2563-8W	2563-8B	2563U8M	2563-8C
34"	4273	5'	2568U5	2568-5W	2568-5B	2568U5M	2568-5C
		6'	2568U6	2568-6W	2568-6B	2568U6M	2568-6C
		8'	2568U8	2568-8W	2568-8B	2568U8M	2568-8C
30" W Cabinets							
29 ¹ / ₂ "	4443	5'	2561U5	2561-5W	2561-5B	2561U5M	2561-5C
		6'	2561U6	2561-6W	2561-6B	2561U6M	2561-6C
		8'	2561U8	2561-8W	2561-8B	2561U8M	2561-8C
34"	4433	5'	2566U5	2566-5W	2566-5B	2566U5M	2566-5C
		6'	2566U6	2566-6W	2566-6B	2566U6M	2566-6C
		8'	2566U8	2566-8W	2566-8B	2566U8M	2566-8C

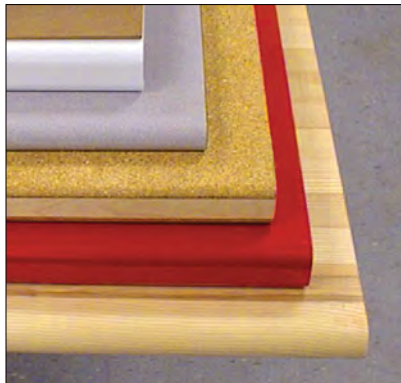

Height	Cabinet Model No.	Length	Steel With Backstop	Wood Top Hardwood	Wood Top Bonded Wood	Hardboard With Backstop	ESD Anti-Static
30" W Cabinets							
34"	4433	5'	2586U5	2586-5W	2586-5B	2586U5M	2586-5C
		6'	2586U6	2586-6W	2586-6B	2586U6M	2586-6C
		8'	2586U8	2586-8W	2586-8B	2586U8M	2586-8C
34"	4433	5'	2576U5	2576-5W	2576-5B	2576U5M	2576-5C
		6'	2576U6	2576-6W	2576-6B	2576U6M	2576-6C
		8'	2576U8	2576-8W	2576-8B	2576U8M	2576-8C
29 ¹ / ₂ "	4443	8'	2591U8	2591-8W	2591-8B	2591U8M	2591-8C
34"	4433	8'	2596U8	2596-8W	2596-8B	2596U8M	2596-8C

Tops

Choice of 6 tops:

Tempered hardboard bonded to 12 gauge steel; Plastic laminate (color: cloud spectrum); ESD (anti-static, color: cloud spectrum - not shown); 3/8" resin wood bonded to wood block core; 12 gauge (.104") steel (painted red in photo); solid laminated hardwood.

All 8' benches in this Modular Drawer Workcenter section are on 8' centers with an 8' top. Pages 111-112 feature Workcenter Accessories for these benches.

A standard color chart is available on page 150.

Pedestal Workcenters

Equipto Pedestal Benches offer the perfect bench/cabinet combination and feature strong, rugged work surfaces, lower shelf space and lockable cabinets and drawers. Customize with accessories and over 180 combinations of height, length, depth, and top surfaces.

- Bench can be customized to fit your specific needs
- Choice of 6 tops available in 4 lengths
- Lower recessed shelf
- Door cabinets have middle shelf
- **All benches are 30" deep**
- **All Cabinets are 34"H x 15"W**
- 1800 lb. capacity – no levelers

Pedestal Workcenter - Preconfigured Units

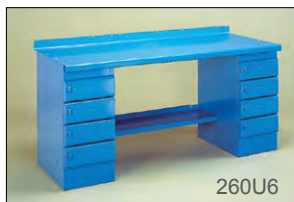

Series	Length	Steel Tops Backstop		Wood Tops		Hardboard on Steel Backstop		ESD Anti-Static
		With	Without	Hardwood	Bonded Wood	With	Without	
250 Series - Includes 2 Door Pedestals								
	4'	250U4	250D4	250-4W	250-4B	250U4M	250D4M	250-4C
	5'	250U5	250D5	250-5W	250-5B	250U5M	250D5M	250-5C
	6'	250U6	250D6	250-6W	250-6B	250U6M	250D6M	250-6C
	8'	250U8	250D8	250-8W	250-8B	250U8M	250D8M	250-8C
255 Series - Includes 1 Drawer Pedestal And 1 Door Pedestal								
	4'	255U4	255D4	255-4W	255-4B	255U4M	255D4M	255-4C
	5'	255U5	255D5	255-5W	255-5B	255U5M	255D5M	255-5C
	6'	255U6	255D6	255-6W	255-6B	255U6M	255D6M	255-6C
	8'	255U8	255D8	255-8W	255-8B	255U8M	255D8M	255-8C
260 Series - Includes 2 Drawer Pedestals								
	4'	260U4	260D4	260-4W	260-4B	260U4M	260D4M	260-4C
	5'	260U5	260D5	260-5W	260-5B	260U5M	260D5M	260-5C
	6'	260U6	260D6	260-6W	260-6B	260U6M	260D6M	260-6C
	8'	260U8	260D8	260-8W	260-8B	260U8M	260D8M	260-8C

On 8' benches, the legs are on 6' centers. The top overhangs legs 1' on each side.

Pages 111 and 112 Feature Productivity Enhancements for These Benches.



Series	Length	Steel Tops Backstop		Wood Tops		Hardboard on Steel Backstop		ESD Anti-Static
		With	Without	Hardwood	Bonded Wood	With	Without	
240 Series - Includes 1 Closed Leg And 1 Door Pedestal								
	4'	240U4	240D4	240-4W	240-4B	240U4M	240D4M	240-4C
	5'	240U5	240D5	240-5W	240-5B	240U5M	240D5M	240-5C
	6'	240U6	240D6	240-6W	240-6B	240U6M	240D6M	240-6C
	8'	240U8	240D8	240-8W	240-8B	240U8M	240D8M	240-8C
245 Series - Includes 1 Closed Leg And 1 Drawer Pedestal								
	4'	245U4	245D4	245-4W	245-4B	245U4M	245D4M	245-4C
	5'	245U5	245D5	245-5W	245-5B	245U5M	245D5M	245-5C
	6'	245U6	245D6	245-6W	245-6B	245U6M	245D6M	245-6C
	8'	245U8	245D8	245-8W	245-8B	245U8M	245D8M	245-8C

On 8' benches, the legs are on 6' centers. The top overhangs legs 1' on each side.

Pages 111 and 112 feature Accessories for these benches.

Flush locks not included. (Part No. 10405 for each drawer) or user supplied padlock.

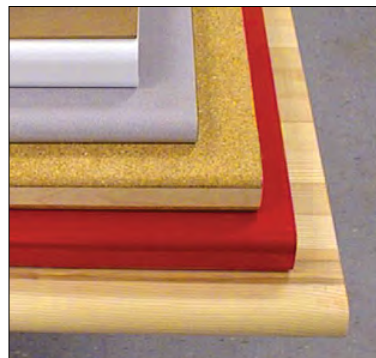

Tops

Choice of 6 tops:

- tempered hardboard bonded to 12 gauge steel;
- plastic laminate (color: cloud spectrum); ESD (anti-static, color: cloud spectrum - Not shown);
- 3/8" resin wood bonded to wood block core;
- 12 gauge (.104") steel; solid laminated hardwood.

For drawer specifications see pg. 111.

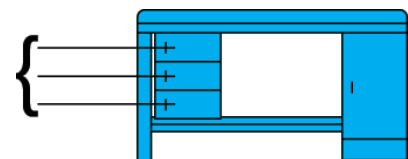

As many as 9 drawers (6 in the 4' unit) can be added to the 210 and 215 series benches.

Closed Leg Workcenters

Equipto closed leg benches combine high-efficiency bench features with the important benefits of cabinet space. Choose from more than 200 sizes and styles and a range of features to match your exact needs. Rugged structural unit designed for tough use with the flexibility for adding accessories.

Closed Leg Workcenter - Preconfigured Units

Benches are all 30" deep and 34" high.

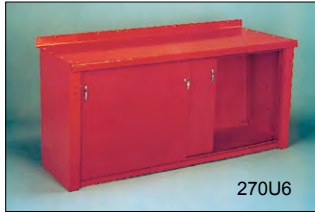

270U6



275U6



280U6



210U6



215U6

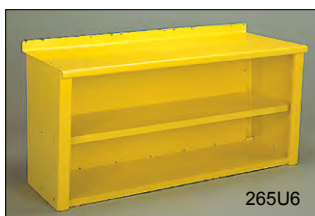

265U6

Series	Length	Steel Tops Backstop		Wood Tops Bonded		Hardboard on Steel Backstop		ESD Anti-Static
		With	Without	Hardwood	Wood	With	Without	
270 Series - Includes Doors Only								
	4'	270U4	270D4	270-4W	270-4B	270U4M	270D4M	270-4C
	5'	270U5	270D5	270-5W	270-5B	270U5M	270D5M	270-5C
	6'	270U6	270D6	270-6W	270-6B	270U6M	270D6M	270-6C
	8'	270U8	270D8	270-8W	270-8B	270U8M	270D8M	270-8C

275 Series - Includes Doors & 1 Shelf (top photo)								
	4'	275U4	275D4	275-4W	275-4B	275U4M	275D4M	275-4C
	5'	275U5	275D5	275-5W	275-5B	275U5M	275D5M	275-5C
	6'	275U6	275D6	275-6W	275-6B	275U6M	275D6M	275-6C
	8'	275U8	275D8	275-8W	275-8B	275U8M	275D8M	275-8C

280 Series - Includes 1 Shelf & 1 Drawer								
	4'	280U4	280D4	280-4W	280-4B	280U4M	280D4M	280-4C
	5'	280U5	280D5	280-5W	280-5B	280U5M	280D5M	280-5C
	6'	280U6	280D6	280-6W	280-6B	280U6M	280D6M	280-6C
	8'	280U8	280D8	280-8W	280-8B	280U8M	280D8M	280-8C

Series	Length	Steel Tops Backstop		Wood Tops Bonded		Hardboard on Steel Backstop		ESD Anti-Static
		With	Without	Hardwood	Wood	With	Without	
210 Series - Open Backed Bench , Includes 1 Half Shelf And 1 Drawer								
	4'	210U4	210D4	210-4W	210-4B	210U4M	210D4M	210-4C
	5'	210U5	210D5	210-5W	210-5B	210U5M	210D5M	210-5C
	6'	210U6	210D6	210-6W	210-6B	210U6M	210D6M	210-6C
	8'	210U8	210D8	210-8W	210-8B	210U8M	210D8M	210-8C

215 Series - Open Backed Bench , Includes 1 Half Shelf								
	4'	215U4	215D4	215-4W	215-4B	215U4M	215D4M	215-4C
	5'	215U5	215D5	215-5W	215-5B	215U5M	215D5M	215-5C
	6'	215U6	215D6	215-6W	215-6B	215U6M	215D6M	215-6C
	8'	215U8	215D8	215-8W	215-8B	215U8M	215D8M	215-8C

265 Series - Closed Backed Bench , Includes 1 Full Shelf								
	4'	265U4	265D4	265-4W	265-4B	265U4M	265D4M	265-4C
	5'	265U5	265D5	265-5W	265-5B	265U5M	265D5M	265-5C
	6'	265U6	265D6	265-6W	265-6B	265U6M	265D6M	265-6C
	8'	265U8	265D8	265-8W	265-8B	265U8M	265D8M	265-8C

Casters for 4' Wide: 2205-4, 5' Wide: 2205-5, 6' Wide: 2205-6

On 8' benches, the legs are on 6' centers. The top overhangs legs 1' on each side.

Pages 111-113 feature Productivity Enhancements for these benches.

A standard color chart is available on page 150.

Closed Leg and Pedestal Workcenter - Accessories Only

Pedestal for Benches

Description	Part No.
Door pedestal (no top)	233LT
4-drawer pedestal (no top)	237LT

Legs for Benches

Description	Part No.
Left hand closed leg panel	230L
Right hand closed leg panel	230R

Bench Shelves

Bench Series No.	Bench Length	Shelf Depth	Part No.
210 & 215 Series	4'	11 1/2"	6322
	5'	11 1/2"	6323
	6'	11 1/2"	6312
	8'	11 1/2"	6312
240 & 245 Series	4'	11 1/2"	6330
	5'	11 1/2"	6334
	6'	11 1/2"	6313
	8'	11 1/2"	6313
250 Series	4'	11 1/2"	6332
255 Series	5'	11 1/2"	6336
260 Series	6'	11 1/2"	6314
	8'	11 1/2"	6314

Bench Series No.	Bench Length	Shelf Depth	Part No.
265 & 270 Series	4'	19 3/4"	6327A
275 & 280 Series	5'	19 3/4"	6328A
(Intermediate Shelves)	6'	19 3/4"	6329A
	8'	19 3/4"	6329A
265 & 270 Series	4'	20 1/4"	6315
275 & 280 Series	5'	20 1/4"	6316
(Bottom Shelves)	6'	20 1/4"	6317
	8'	20 1/4"	6317

Adjustable Height Iron-I Workcenters

Equipto's Iron-I workcenters are completely adjustable and are available in 2 depths and 4 lengths with over 35 varying leg heights! You can choose from 5 standard tops to customize to your specific requirements

- Adjustable height 26" to 44"
- Three-way adjustable shelf
- Electrical, air and fluid power knockouts on each leg
- Heavy-Duty cantilever leg design eliminates obstruction of corner leg design

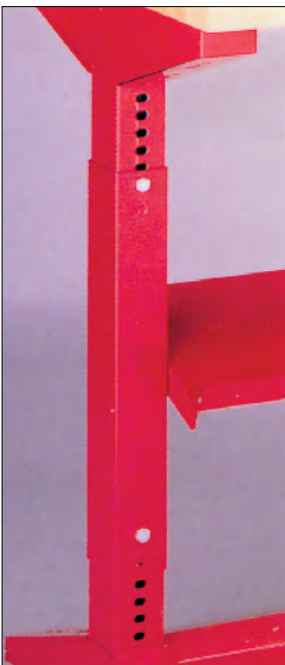

Fully Adjustable
Leg heights from 26" to 44" in 1/2" increments.



Adjust position
Shelf can be adjusted to be closer to front or back of bench.



Adjustable slope
Shelf can be sloped toward front or toward rear of bench.



Adjustable height
Shelf can be located in any one of 3 height positions.



Electric power
Each bench has knockouts for 8 electrical outlets. Knockouts are in both top and bottom of each leg.

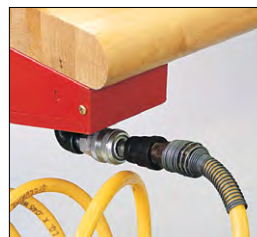

Air or fluid power
Each bench has 4 knockouts for Air or Fluid power. Knockouts are in both top and bottom of leg.



Optional levelers
Each bench leg can be equipped with an optional leveler to achieve exact height and level needed. Part No. 11650-04

Pages 111-113 feature Productivity Enhancements for these benches.

A standard color chart is available on page 150.

Adjustable Height Iron-I Workcenter - Preconfigured Units

- Lower shelf adjusts to three heights and tilts front or back to fit your application
- More than 450 pre-configured options
- Back and side rails keep parts on top of workcenter
- Adjustable from 26" to 36" or from 34" to 44" in 1/2" increments to meet your exact height requirements
- Aerial shelf adds space for increased productivity
- Depending on type of top, workbench will support up to 1,800 lbs.

Iron-I Bench without shelf

Depth	Height	Length	Steel Tops		Wood Tops		Hardboard on Steel		ESD Anti-Static	
			Backstop		Hardwood	Bonded Wood	Backstop			
			With	Without					With	Without
30" Depth										
26"	4'	4'	421U4	421D4	421-4W	421-4B	421U4M	421D4M	421-4C	
to	5'	4'	421U5	421D5	421-5W	421-5B	421U5M	421D5M	421-5C	
36"	6'	6'	421U6	421D6	421-6W	421-6B	421U6M	421D6M	421-6C	
	8'	8'	421U8	421D8	421-8W	421-8B	421U8M	421D8M	421-8C	
34" Depth										
34"	4'	4'	422U4	422D4	422-4W	422-4B	422U4M	422D4M	422-4C	
to	5'	4'	422U5	422D5	422-5W	422-5B	422U5M	422D5M	422-5C	
44"	6'	6'	422U6	422D6	422-6W	422-6B	422U6M	422D6M	422-6C	
	8'	8'	422U8	422D8	422-8W	422-8B	422U8M	422D8M	422-8C	
36" Depth										
26"	4'	4'	431U4	431D4	431-4W	431-4B	431U4M	431D4M	431-4C	
to	5'	4'	431U5	431D5	431-5W	431-5B	431U5M	431D5M	431-5C	
36"	6'	6'	431U6	431D6	431-6W	431-6B	431U6M	431D6M	431-6C	
	8'	8'	431U8	431D8	431-8W	431-8B	431U8M	431D8M	431-8C	
34" Depth										
34"	4'	4'	432U4	432D4	432-4W	432-4B	432U4M	432D4M	432-4C	
to	5'	4'	432U5	432D5	432-5W	432-5B	432U5M	432D5M	432-5C	
44"	6'	6'	432U6	432D6	432-6W	432-6B	432U6M	432D6M	432-6C	
	8'	8'	432U8	432D8	432-8W	432-8B	432U8M	432D8M	432-8C	



Iron-I Bench without lower shelf

8' bench legs are on 6' centers. The top overhangs legs 1' on each side.

Pages 111-113 feature Productivity Enhancements for these benches.

Iron-I Bench with lower shelf

Depth	Height	Length	Steel Tops		Wood Tops		Hardboard on Steel		ESD Anti-Static	
			Backstop		Hardwood	Bonded Wood	Backstop			
			With	Without					With	Without
30" Depth										
26"	4'	4'	423U4	423D4	423-4W	423-4B	423U4M	423D4M	423-4C	
to	5'	4'	423U5	423D5	423-5W	423-5B	423U5M	423D5M	423-5C	
36"	6'	6'	423U6	423D6	423-6W	423-6B	423U6M	423D6M	423-6C	
	8'	8'	423U8	423D8	423-8W	423-8B	423U8M	423D8M	423-8C	
34" Depth										
34"	4'	4'	424U4	424D4	424-4W	424-4B	424U4M	424D4M	424-4C	
to	5'	4'	424U5	424D5	424-5W	424-5B	424U5M	424D5M	424-5C	
44"	6'	6'	424U6	424D6	424-6W	424-6B	424U6M	424D6M	424-6C	
	8'	8'	424U8	424D8	424-8W	424-8B	424U8M	424D8M	424-8C	
36" Depth										
26"	4'	4'	433U4	433D4	433-4W	433-4B	433U4M	433D4M	433-4C	
to	5'	4'	433U5	433D5	433-5W	433-5B	433U5M	433D5M	433-5C	
36"	6'	6'	433U6	433D6	433-6W	433-6B	433U6M	433D6M	433-6C	
	8'	8'	433U8	433D8	433-8W	433-8B	433U8M	433D8M	433-8C	
34" Depth										
34"	4'	4'	434U4	434D4	434-4W	434-4B	434U4M	434D4M	434-4C	
to	5'	4'	434U5	434D5	434-5W	434-5B	434U5M	434D5M	434-5C	
44"	6'	6'	434U6	434D6	434-6W	434-6B	434U6M	434D6M	434-6C	
	8'	8'	434U8	434D8	434-8W	434-8B	434U8M	434D8M	434-8C	



Iron-I Bench with lower shelf

8' bench legs are on 6' centers. The top overhangs legs 1' on each side.

Pages 111-113 feature Productivity Enhancements for these benches.

A standard color chart is available on page 150.

Adjustable Height Iron-I Workcenter - Preconfigured Units cont'd

Iron-I Bench with lower shelf and rails

		Wood Tops				
Height	Length	Steel with Backstop	Hardwood	Bonded Wood	Hardboard with Backstop	ESD Anti-Static
30" Depth						
26"	4'	425U4	425-4W	425-4B	425U4M	425-4C
to	5'	425U5	425-5W	425-5B	425U5M	425-5C
36"	6'	425U6	425-6W	425-6B	425U6M	425-6C
	8'	425U8	425-8W	425-8B	425U8M	425-8C
34"	4'	426U4	426-4W	426-4B	426U4M	426-4C
to	5'	426U5	426-5W	426-5B	426U5M	426-5C
44"	6'	426U6	426-6W	426-6B	426U6M	426-6C
	8'	426U8	426-8W	426-8B	426U8M	426-8C
36" Depth						
26"	4'	435U4	435-4W	435-4B	435U4M	435-4C
to	5'	435U5	435-5W	435-5B	435U5M	435-5C
36"	6'	435U6	435-6W	435-6B	435U6M	435-6C
	8'	435U8	435-8W	435-8B	435U8M	435-8C
34"	4'	436U4	436-4W	436-4B	436U4M	436-4C
to	5'	436U5	436-5W	436-5B	436U5M	436-5C
44"	6'	436U6	436-6W	436-6B	436U6M	436-6C
	8'	436U8	436-8W	436-8B	436U8M	436-8C



Iron-I Bench with lower shelf, and side and back rails

8' bench legs are on 6' centers. The top overhangs legs 1' on each side.
Pages 111-113 feature Productivity Enhancements for these benches.

Iron-I Bench with lower shelf, aerial shelf, drawer, and rails

		Wood Tops					
Depth	Height	Length	Steel with Backstop	Hardwood	Bonded Wood	Hardboard with Backstop	ESD Anti-Static
30" Depth							
		4'	427U4	427-4W	427-4B	427U4M	427-4C
26"		5'	427U5	427-5W	427-5B	427U5M	427-5C
to		6'	427U6	427-6W	427-6B	427U6M	427-6C
36"		8'	427U8	427-8W	427-8B	427U8M	427-8C
34"	4'		428U4	428-4W	428-4B	428U4M	428-4C
to	5'		428U5	428-5W	428-5B	428U5M	428-5C
44"	6'		428U6	428-6W	428-6B	428U6M	428-6C
	8'		428U8	428-8W	428-8B	428U8M	428-8C
36" Depth							
		4'	437U4	437-4W	437-4B	437U4M	437-4C
26"		5'	437U5	437-5W	437-5B	437U5M	437-5C
to		6'	437U6	437-6W	437-6B	437U6M	437-6C
36"		8'	437U8	437-8W	437-8B	437U8M	437-8C
34"	4'		438U4	438-4W	438-4B	438U4M	438-4C
to	5'		438U5	438-5W	438-5B	438U5M	438-5C
44"	6'		438U6	438-6W	438-6B	438U6M	438-6C
	8'		438U8	438-8W	438-8B	438U8M	438-8C



Iron-I Bench with lower shelf, aerial shelf, drawer and rails

8' bench legs are on 6' centers. The top overhangs legs 1' on each side.
Pages 111-113 feature Productivity Enhancements for these benches.

Workcenters & Workbenches

Open Leg Workcenters

A simple and convenient way to achieve efficient work space with economy and endurance. This basic unit is designed to boost your productivity over years and years of demanding use.

Open Leg Workcenter - 2200 series

Depth	Height	Length	Steel Top Backstop		Wood Tops Bonded		Hardboard Backstop		ESD Anti-Static
			With	Without	Hardwood	Wood	With	Without	
30" Depth									
29"	4'		2221U4	2221D4	2221-4W	2221-4B	2221U4M	2221D4M	2221-4C
	5'		2221U5	2221D5	2221-5W	2221-5B	2221U5M	2221D5M	2221-5C
	6'		2221U6	2221D6	2221-6W	2221-6B	2221U6M	2221D6M	2221-6C
31 1/4"	4'		2221U8	2221D8	2221-8W	2221-8B	2221U8M	2221D8M	2221-8C
	5'		2222U4	2222D4	2222-4W	2222-4B	2222U4M	2222D4M	2222-4C
	6'		2222U5	2222D5	2222-5W	2222-5B	2222U5M	2222D5M	2222-5C
34"	4'		2222U6	2222D6	2222-6W	2222-6B	2222U6M	2222D6M	2222-6C
	5'		2222U8	2222D8	2222-8W	2222-8B	2222U8M	2222D8M	2222-8C
	6'		2223U4	2223D4	2223-4W	2223-4B	2223U4M	2223D4M	2223-4C
36"	4'		2223U5	2223D5	2223-5W	2223-5B	2223U5M	2223D5M	2223-5C
	5'		2223U6	2223D6	2223-6W	2223-6B	2223U6M	2223D6M	2223-6C
	6'		2223U8	2223D8	2223-8W	2223-8B	2223U8M	2223D8M	2223-8C



Open leg bench **without** lower shelf

8" bench legs are on 6" centers. The top overhangs legs 1" on each side.

Open Leg Workcenter - 2300 series

As rugged as the basic open leg unit, with the added feature of a spacious lower shelf. The 2300 series provides superior strength, with built-in versatility for adapting, adding on and custom building to match bench capability to your work needs.

Depth	Height	Length	Steel Top Backstop		Wood Tops Bonded		Hardboard Backstop		ESD Anti-Static
			With	Without	Hardwood	Wood	With	Without	
30" Depth									
29"	4'		2321U4	2321D4	2321-4W	2321-4B	2321U4M	2321D4M	2321-4C
	5'		2321U5	2321D5	2321-5W	2321-5B	2321U5M	2321D5M	2321-5C
	6'		2321U6	2321D6	2321-6W	2321-6B	2321U6M	2321D6M	2321-6C
31 1/4"	4'		2321U8	2321D8	2321-8W	2321-8B	2321U8M	2321D8M	2321-8C
	5'		2322U4	2322D4	2322-4W	2322-4B	2322U4M	2322D4M	2322-4C
	6'		2322U5	2322D5	2322-5W	2322-5B	2322U5M	2322D5M	2322-5C
34"	4'		2322U6	2322D6	2322-6W	2322-6B	2322U6M	2322D6M	2322-6C
	5'		2322U8	2322D8	2322-8W	2322-8B	2322U8M	2322D8M	2322-8C
	6'		2323U4	2323D4	2323-4W	2323-4B	2323U4M	2323D4M	2323-4C
36"	4'		2323U5	2323D5	2323-5W	2323-5B	2323U5M	2323D5M	2323-5C
	5'		2323U6	2323D6	2323-6W	2323-6B	2323U6M	2323D6M	2323-6C
	6'		2323U8	2323D8	2323-8W	2323-8B	2323U8M	2323D8M	2323-8C



Open leg bench **with** lower shelf

8" bench legs are on 6" centers. The top overhangs legs 1" on each side.

Pages 111-113 feature Productivity Enhancements for these benches.

A standard color chart is available on page 150.

Workcenters & Workbenches

Carefully engineered for rugged use with 3 sides of the top enclosed, and a bottom shelf. Equipto Series 2400 Open Leg Workcenters are extremely versatile units. Completely modular, completely flexible - with variations to match any work area requirements. A full range of easily-added accessories further expands your options.

Open Leg Workcenters - 2400 series

Depth	Height	Length	Wood Tops				
			Steel with Backstop	Hardwood	Bonded Wood	Hardboard with Backstop	ESD Anti-Static
30" Depth							
29"	4'		2421U4	2421-4W	2421-4B	2421U4M	2421-4C
	5'		2421U5	2421-5W	2421-5B	2421U5M	2421-5C
	6'		2421U6	2421-6W	2421-6B	2421U6M	2421-6C
31 1/4"	4'		2422U4	2422-4W	2422-4B	2422U4M	2422-4C
	5'		2422U5	2422-5W	2422-5B	2422U5M	2422-5C
	6'		2422U6	2422-6W	2422-6B	2422U6M	2422-6C
34"	4'		2423U4	2423-4W	2423-4B	2423U4M	2423-4C
	5'		2423U5	2423-5W	2423-5B	2423U5M	2423-5C
	6'		2423U6	2423-6W	2423-6B	2423U6M	2423-6C
8'			2422U8	2422-8W	2422-8B	2422U8M	2422-8C
			2423U8	2423-8W	2423-8B	2423U8M	2423-8C
			2423U8	2423-8W	2423-8B	2423U8M	2423-8C
36" Depth							
29"	4'		2431U4	2431-4W	2431-4B	2431U4M	2431-4C
	5'		2431U5	2431-5W	2431-5B	2431U5M	2431-5C
	6'		2431U6	2431-6W	2431-6B	2431U6M	2431-6C
31 1/4"	4'		2432U4	2432-4W	2432-4B	2432U4M	2432-4C
	5'		2432U5	2432-5W	2432-5B	2432U5M	2432-5C
	6'		2432U6	2432-6W	2432-6B	2432U6M	2432-6C
34"	4'		2433U4	2433-4W	2433-4B	2433U4M	2433-4C
	5'		2433U5	2433-5W	2433-5B	2433U5M	2433-5C
	6'		2433U6	2433-6W	2433-6B	2433U6M	2433-6C
8'			2433U8	2433-8W	2433-8B	2433U8M	2433-8C
			2433U8	2433-8W	2433-8B	2433U8M	2433-8C
			2433U8	2433-8W	2433-8B	2433U8M	2433-8C



Open leg bench with lower shelf and side and back rails

Replace the letter at the end of the part numbers with a "P" to order with a plastic laminate top. Ex. 2423-6C to 2423-6P

8' bench legs are on 6' centers. The top overhangs legs 1' on each side.

Open Leg Workcenters - 2500 series

An open, modular style unit with standard features that increase bench efficiency. Everything you need to accommodate your situation — with 3 sides enclosed, aerial shelf, lower shelf, and drawer space all in one rugged unit.

Depth	Height	Length	Wood Tops				
			Steel with Backstop	Hardwood	Bonded Wood	Hardboard with Backstop	ESD Anti-Static
30" Depth							
29"	4'		2521U4	2521-4W	2521-4B	2521U4M	2521-4C
	5'		2521U5	2521-5W	2521-5B	2521U5M	2521-5C
	6'		2521U6	2521-6W	2521-6B	2521U6M	2521-6C
31 1/4"	4'		2522U4	2522-4W	2522-4B	2522U4M	2522-4C
	5'		2522U5	2522-5W	2522-5B	2522U5M	2522-5C
	6'		2522U6	2522-6W	2522-6B	2522U6M	2522-6C
34"	4'		2523U4	2523-4W	2523-4B	2523U4M	2523-4C
	5'		2523U5	2523-5W	2523-5B	2523U5M	2523-5C
	6'		2523U6	2523-6W	2523-6B	2523U6M	2523-6C
8'			2523U8	2523-8W	2523-8B	2523U8M	2523-8C
			2523U8	2523-8W	2523-8B	2523U8M	2523-8C
			2523U8	2523-8W	2523-8B	2523U8M	2523-8C
36" Depth							
29"	4'		2531U4	2531-4W	2531-4B	2531U4M	2531-4C
	5'		2531U5	2531-5W	2531-5B	2531U5M	2531-5C
	6'		2531U6	2531-6W	2531-6B	2531U6M	2531-6C
31 1/4"	4'		2532U4	2532-4W	2532-4B	2532U4M	2532-4C
	5'		2532U5	2532-5W	2532-5B	2532U5M	2532-5C
	6'		2532U6	2532-6W	2532-6B	2532U6M	2532-6C
34"	4'		2533U4	2533-4W	2533-4B	2533U4M	2533-4C
	5'		2533U5	2533-5W	2533-5B	2533U5M	2533-5C
	6'		2533U6	2533-6W	2533-6B	2533U6M	2533-6C
8'			2533U8	2533-8W	2533-8B	2533U8M	2533-8C
			2533U8	2533-8W	2533-8B	2533U8M	2533-8C
			2533U8	2533-8W	2533-8B	2533U8M	2533-8C



Open leg bench with lower shelf, side and back rails, aerial shelf and a drawer

Workcenters & Workbenches

8' bench legs are on 6' centers. The top overhangs legs 1' on each side.

Pages 111-113 feature Productivity Enhancements for these benches.

A standard color chart is available on page 150.

Teardown Bench

Teardown Bench features and benefits

- Ideal for working on transmissions, small engines and hydraulic components
- Reinforced work surface will stand up to years of heavy use
- Top has a 3/4" high retaining lip on all sides tapering to the rear center to a 1/2" threaded and plumbed drain
- Optional caster kit consists of 4 swivel 7 1/2"H casters
- 1/2" threaded drain nipple allows for connection of a hose to divert fluid to a storage container; or capture fluid with an optional fluid container kit



2303DT shown with optional fluid container, drawer kit and shelf.

Teardown Benches

Part No.	Description	Capacity	Depth	Width	Leg Height
2301DT	Steel Top		30"	48"	29"
2303DT	Steel Top		30"	48"	34"
2311DT	Steel Top		30"	60"	29"
2313DT	Steel Top		30"	60"	34"
2301DTSS	Stainless Steel Top		30"	48"	29"
2303DTSS	Stainless Steel Top		30"	48"	34"
2311DTSS	Stainless Steel Top		30"	60"	29"
2313DTSS	Stainless Steel Top		30"	60"	34"

Kits and Accessories

Part No.	Description
TDFLKT48	Fluid Container Kit w/ Channels – 48"
TDFLKT60	Fluid Container Kit w/ Channels – 60"
TDDWKT48	Drawer Kit w/ Channels – 48"
TDDWKT60	Drawer Kit w/ Channels – 60"
TDFLDWKT48	Fluid Container & Drawer Kit w/ Channels – 48"
TDFLDWKT60	Fluid Container & Drawer Kit w/ Channels – 60"
2203	Caster Kit – 30"
6120	Bottom Shelf – 48"
6121	Bottom Shelf – 60"

*Kit support channels are required when ordering a fluid container kit or a drawer kit. If both kits are ordered for the same bench, only one set of kit support channels is needed.

Wall mount Open Leg Bench

Depth	Length	Wood Tops				ESD Anti-Static
		Steel Tops With Backstop	Hardwood	Bonded Wood	Hardboard With Backstop	
30" Depth						
	30"	2340U3	2340-3W	2340-3B	2340U3M	—
	4'	2340U4	2340-4W	2340-4B	2340U4M	2340-4C
	5'	2340U5	2340-5W	2340-5B	2340U5M	2340-5C
	6'	2340U6	2340-6W	2340-6B	2340U6M	2340-6C
	8'	2340U8	2340-8W	2340-8B	2340U8M	2340-8C
36" Depth						
	30"	2345U3	2345-3W	2345-3B	2345U3M	—
	4'	2345U4	2345-4W	2345-4B	2345U4M	2345-4C
	5'	2345U5	2345-5W	2345-5B	2345U5M	2345-5C
	6'	2345U6	2345-6W	2345-6B	2345U6M	2345-6C
	8'	2345U8	2345-8W	2345-8B	2345U8M	2345-8C



2307DT Fluid Container Kit



221DT - Drawer Kit



2203 - Caster Kit

- Easy to anchor to wall
- Clean-up of work area is easy
- Efficient use of wall space



2345U6

A standard color chart is available on page 150.

Open Leg Workcenters - Accessories

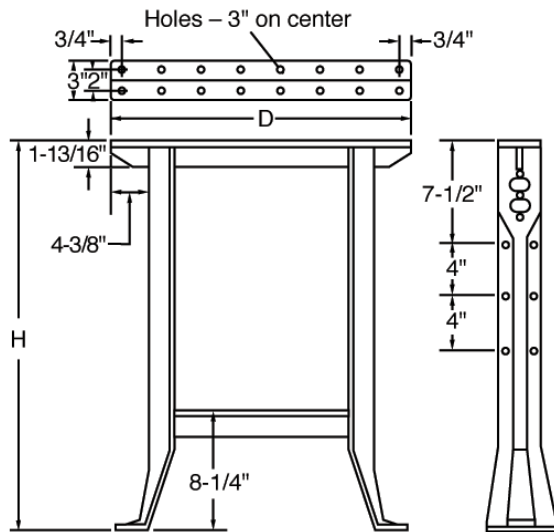

Bottom Shelves

Description	Part No.
12 ⁷ / ₈ " x 4'	6120
12 ⁷ / ₈ " x 5'	6121
12 ⁷ / ₈ " x 6'	6122

Mobile Caster Kit for Open Leg Bench

Mobile Kit adds 7¹/₂" to the height of bench

Depth	Part No.
30"	2203
36"	2204

Closed Leg Bench Caster Sets

Part No.	Description
2205-4	4' long bench
2205-5	5' long bench
2205-6	6' & 8' long bench

Caster kits include: (4) locking swivel casters
 1200 total lb. capacity per set of 4



Bench Legs

Welded, one-piece steel units seamed for strength and safety.

Depth	Height	Part No.
Nominal 30"		
28 ¹ / ₂ "	29"	9921
28 ¹ / ₂ "	31 ¹ / ₄ "	9922
28 ¹ / ₂ "	34"	9923
Nominal 36"		
34 ¹ / ₂ "	29"	9931
34 ¹ / ₂ "	31 ¹ / ₄ "	9932
34 ¹ / ₂ "	34"	9933

Back Stringers

Size	Part No.
4'	10251
5'	10252
6'	10253



Bench Legs

Depth	Height	Part No.
29"	26" - 36"	420L30
35"	26" - 36"	420L36
29"	34" - 44"	420H30
35"	34" - 44"	420H36

Iron-I Workcenter - Accessories

Equipto Iron-I Benches have the flexibility for planned expansion. Our parts and accessories allow you to keep up with changing requirements.

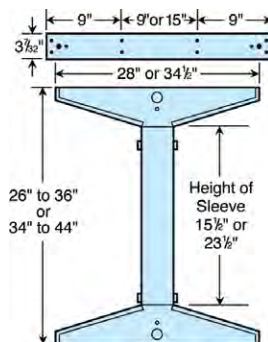

The Iron-I's legs adjust from heights of 26" to 44" in 1/2" increments. All structural parts are 12 gauge (.104") steel. Each leg will support 1,000 lbs.

Bench Base

Length	Part No.
4'	6844
5'	6845
6'	6846

Swivel Caster Set (4)

Part No.	Description
11649-04	non-locking
11649-04L	with lock
11649-04HR	hard rubber
11649-04HRL	hard rubber w/ lock

Leveler Set

Quantity	Part No.
4	11650-04

Bottom Shelves

Description	Part No.
13 ¹ / ₂ " x 48"	6054
13 ¹ / ₂ " x 60"	6055
13 ¹ / ₂ " x 72"	6056

Workcenters & Workbenches

Workcenter Accessories

Production Boosters

- Can be used on any work bench
- Hands off use for manuals and instruments
- Shelves adjust to any angle, tip toward front or back
- Safely holds expensive test equipment
- Can triple work surface

A. 14" High Unit	For 4' Bench	For 5' Bench	For 6' Bench
With 1 Shelf	454T48	454T60	454T72
B. 24" High Unit	For 4' Bench	For 5' Bench	For 6' Bench
With 1 Shelf	451T48	451T60	451T72
With 2 Shelves	452T48	452T60	452T72
With 3 Shelves	453T48	453T60	453T72
D. 36" High Unit	For 4' Bench	For 5' Bench	For 6' Bench
With 1 Shelf	461T48	461T60	461T72
With 2 Shelves	462T48	462T60	462T72
With 3 Shelves	463T48	463T60	463T72
Extra Top Shelves	450T48	450T60	450T72

For additional intermediate shelves please contact Equipto Inside Sales

C. Cabinet	
13" D x 30" W x 27" H	Part No. 1734DI
2 required for 5' bench	
13" D x 36" W x 27" H	Part No. 1735DI
2 required for 6' bench	

None available for 4' benches

NOTE: To order production booster with top shelf that can be tilted, substitute "—" for "T" in part number.

Intermediate shelves are 13^{1/2}" D x 44", 56" or 68" L

Full length top shelves are 13^{1/2}" D x 48", 60" or 72" L

Drawers

Pilfer-proof, enclosed frame, in 2 widths and heights, for mounting up to 3 drawers wide and 3 drawers high with hasp and knockout for locks.



221-2



223

Drawer Size	For Bench Top Type	Starting Unit	Additional Unit	2-Drawer Stack	3-Drawer Stack
Regular Size Overall unit dimensions 15" W x 23 ^{3/4} " L x 6 ^{1/4} " H	Steel or Hardboard on steel	221	221A	221-2	221-3
Regular Size Overall unit dimensions 15" W x 23 ^{3/4} " L x 6 ^{1/4} " H	Wood, laminate, or ESD (Anti-Static)	221A	221A	221A2	221A3
Extra Large Overall unit dimensions 21 ^{1/2} " W x 23 ^{3/4} " L x 7 ^{3/4} " H	Steel or hardboard on steel	223	223A	223-2	223-3*
Extra Large Overall unit dimensions 21 ^{1/2} " W x 23 ^{3/4} " L x 7 ^{3/4} " H	Wood, laminate, or ESD (Anti-Static)	223A	223A	223A2	223A3*

*Note: Fits only benches without bottom shelves



454T72 A



452T72 B



451T72 B



453T72 D

Aerial Shelf

- Added space
- Gain a shelf without losing table top space

All are 12" D x 14" H (For aerial to have back panel add BP to end of Part #)

Part No. 226-30 - 30" W

Part No. 226-48 - 48" W

Part No. 226-60 - 60" W

Part No. 226-72 - 72" W

Part No. 850696-96 - 96" W



Aerial Shelf

NEW!

Aerial Shelf with Back Panel

Developed for 12" D x 14" H Aerial shelves

Part No. 226-30BP - 30" W

Part No. 226-48BP - 48" W

Part No. 226-60BP - 60" W

Part No. 226-72BP - 72" W

Part No. 7989-30 - 30" W back panel only

Part No. 7989-48 - 48" W back panel only

Part No. 7989-60 - 60" W back panel only

Part No. 7989-72 - 72" W back panel only

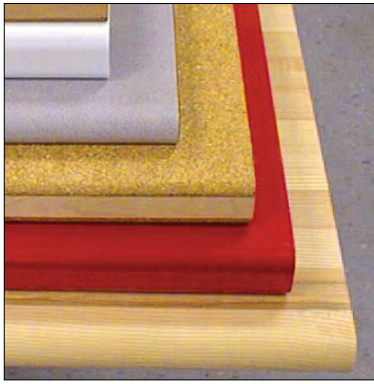

Back Rail — Wood Top

Description	Part No.
4' long	7404
5' long	7405
6' long	7406
8' long	7411
30" long	7407

End Rail — Wood Top

Description	Part No.
30" left	7420L
30" right	7420R
36" left	7421L
36" right	7421R

End Rail — Steel Top

Description	Part No.
30" left	7417L
30" right	7417R
36" left	7418L
36" right	7418R

End Rail — Stainless Steel Top

Description	Part No.
30" left	7417LS
30" right	7417RS

**Accessories - continued
Tops**

Style	Length	30" Deep	30" Deep Stainless Steel	36" Deep
Steel Top	4'	441U4	441U4SS	442U4
(12 gauge)	5'	441U5	441U5SS	442U5
With Backstop	6'	441U6	441U6SS	442U6
	8'	441U8	441U8SS	442U8
Steel Top	4'	441D4	441D4SS	442D4
(12 gauge)	5'	441D5	441D5SS	442D5
Without Backstop	6'	441D6	441D6SS	442D6
	8'	441D8	441D8SS	442D8
Stainless Steel Top	4'	441-4SSW4	—	—
With Wood Core	5'	441-5SSW4	—	—
1 ⁵ / ₈ " thick	6'	441-6SSW4	—	—
	8'	441-8SSW4	—	—
Hardboard	4'	441U4M	—	442U4M
On Steel,	5'	441U5M	—	442U5M
With Backstop	6'	441U6M	—	442U6M
	8'	441U8M	—	442U8M
Hardboard	4'	441D4M	—	442D4M
On Steel,	5'	441D5M	—	442D5M
Without Backstop	6'	441D6M	—	442D6M
	8'	441D8M	—	442D8M
Bonded	4'	441-4B	—	442-4B
Wood,	5'	441-5B	—	442-5B
1 ³ / ₄ " thick	6'	441-6B	—	442-6B
	8'	441-8B	—	442-8B
Hardwood	4'	441-4W	—	442-4W
1 ³ / ₄ " thick	5'	441-5W	—	442-5W
	6'	441-6W	—	442-6W
	8'	441-8W	—	442-8W
ESD	4'	441-4C	—	442-4C
(Anti-Static)	5'	441-5C	—	442-5C
1 ¹ / ₄ " thick	6'	441-6C	—	442-6C
	8'	441-8C	—	442-8C
Plastic Laminate*	4'	441-4P	—	442-4P
1 ¹ / ₄ " thick	5'	441-5P	—	442-5P
	6'	441-6P	—	442-6P
	8'	441-8P	—	442-8P

* plastic laminate unable to span greater than 60" W without center support

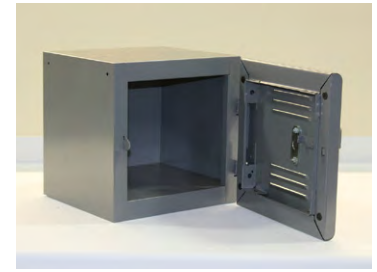

Convenience cube

12" x 12" x 12" cube. Protect fragile items or personalize a workcenter. Lock door with padlock or key lock. Part No. 121212



Locks

Lock assembly fits all bench drawers and doors (padlock hasp is standard).

Description	Part No.
Key lock	10405
Keyed Alike	10405ka

Number Plates

Available for any number from 1 - 500 (please specify).

Number plate	13013
--------------	-------



Electrical Power Center

Compact, with 4 outlets, On-Off switch, 15 Amp breaker, 15 ft. cord with ground. Easy to install where you need it. Part No. 229-4

Workcenters & Workbenches

Equiptoflex Workcenters

This is the most flexible technical workcenter available. Designed ergonomically for the 21st century, it changes with you. Three sizes of cabinets, four sizes of drawers, four sizes of doors and six choices of work surfaces mean almost limitless design options for you. Add to

that, electrical legs, bottom shelves, locks, aerial shelves with or without electrical outlets, and Equipto cabinets, and seating, and you have a total, flexible, technical workcenter. One that adapts to your changing requirements!

- These attractive workcenters compliment and enhance other Equipto workcenters and modular drawers.
- 100% extension on drawers
- Hinged Doors
- Shelves
- Quiet Ride™ drawers
- UL approved fused electrical outlets
- ESD paint available
- 6 work surfaces from which to choose
- 100 lb. capacity per drawer
- Pre-engineered units
- Custom designed units
- Built-in label holder
- Optional unit locking mechanism
- Leveling feet



389 Series

Use In:

- Assembly
- Maintenance
- Manufacturing
- Office
- Hospitals
- Mail Room
- Packaging
- Technical
- Electronics

Equipto Workcenters - Preconfigured Units - 360L (Left Return) and 360R (Right Return)



The right cabinet, in the main work surface area, consists of two 3"H drawers, one 6"H drawer and one 12"H file drawer.

In the left return area, the cabinet consists of two 12" H file drawers.

Main work area is 72"W x 36"D and return is 48"W x 30"D. Work surface is 30"H.

Model 360L - Plastic laminate top. (cloud spectrum)
Model 360LW - Picture shows wood top; optional aerial shelf with wood top is on page 119 and sold separately

To order unit with a right hand return instead of a left hand return order model
360R - Plastic laminate top.
360RW for Wood top

****Wood Tops add 1³/₄" to the overall height of the bench.**

Pullout Keyboard Tray 537

Equiptoflex Workcenter - 29" Desk Height; 30" Deep

363 series

Work Surface Type	Workcenter Widths		
	4'	5'	6'
Plastic Laminate	363R4P	363R5P	363R6P
ESD (Anti-Static)	363R4C	363R5C	363R6C
Hardwood	363R4W	363R5W	363R6W
Bonded Wood	363R4B	363R5B	363R6B

Left hand cabinet with two 3"H drawers; four 4^{1/2}"H drawers. Right hand cabinet with one full height 24"H door and one interior adjustable shelf. To order unit with cabinets reversed left to right, change letter in catalog number from "R" to "L". Bottom shelf on all workcenters. Drawer cabinet has central lock; door has individual lock.



Model 363R5P

364 series

Work Surface Type	Workcenter Widths		
	4'	5'	6'
Plastic Laminate	364R4P	364R5P	364R6P
ESD (Anti-Static)	364R4C	364R5C	364R6C
Hardwood	364R4W	364R5W	364R6W
Bonded Wood	364R4B	364R5B	364R6B

Left hand cabinet with one 3"H drawer; two 4^{1/2}"H drawers; one 12" H hanging file drawer. Right hand cabinet with two 12"H doors and one adjustable shelf between doors. To order unit with cabinets reversed left to right, change letter in catalog number from "R" to "L". Bottom shelf on all work-centers. Drawer cabinet has central lock; doors have individual locks.



Model 364R5P

365 series

Work Surface Type	Workcenter Widths		
	4'	5'	6'
Plastic Laminate	365-4P	365-5P	365-6P
ESD (Anti-Static)	365-4C	365-5C	365-6C
Hardwood	365-4W	365-5W	365-6W
Bonded Wood	365-4B	365-5B	365-6B
12 Gauge Steel	365-4T	365-5T	365-6T
Hardboard on Steel	365-4M	365-5M	365-6M

Left hand cabinet with two 3"H drawers; one 6"H drawer; one 12"H hanging file drawer. Right hand cabinet with two 6"H drawers; and one 12"H hanging file drawer. Bottom shelf on all workcenters. All units complete with cabinet locks.



Model 365-5P

366 series

Work Surface Type	Workcenter Widths		
	4'	5'	6'
Plastic Laminate	366L4P	366L5P	366L6P
ESD (Anti-Static)	366L4C	366L5C	366L6C
Hardwood	366L4W	366L5W	366L6W
Bonded Wood	366L4B	366L5B	366L6B
12 Gauge Steel	366L4T	366L5T	366L6T
Hardboard on Steel	366L4M	366L5M	366L6M

One cabinet with one 3"H drawer; two 4^{1/2}"H drawers; one 12"H hanging file drawer. One pedestal leg with UL approved fused electrical outlets. Bottom shelf on all workcenters. All units complete with cabinet lock. To order unit with cabinet reversed from left to right, change letter in catalog number from "L" to "R".



Model 366L5P

367 series

Work Surface Type	Workcenter Widths		
	4'	5'	6'
Plastic Laminate	367-4P	367-5P	367-6P
ESD (Anti-Static)	367-4C	367-5C	367-6C
Hardwood	367-4W	367-5W	367-6W
Bonded Wood	367-4B	367-5B	367-6B
12 Gauge Steel	367-4T	367-5T	367-6T
Hardboard on Steel	367-4M	367-5M	367-6M

Two pedestal legs with UL approved fused electrical outlets. Bottom shelf and modesty panel on all workcenters.



Model 367-5P

Workcenters & Workbenches

Page 119 features Productivity Enhancements for these benches.

A standard color chart is available on page 150.

Equiptoflex Workcenter - Desk Height 33¹/₂" ; 30" Deep



384 Series

Work Surface Type	Workcenter Width		
	4'	5'	6'
Plastic Laminate	384R4P	384R5P	384R6P
ESD (Anti-Static)	384R4C	384R5C	384R6C
Hardwood	384R4W	384R5W	384R6W
Bonded Wood	384R4B	384R5B	384R6B

Left hand cabinet with one drawer 4¹/₂"H; four drawers 6"H. Right hand cabinet with one full height door, 28¹/₂"H. To order unit with cabinets reversed right to left, change letter in catalog number from "R" to "L". Bottom shelf on all workcenters. Drawer cabinet has central lock; door has individual lock.



385 Series

Work Surface Type	Workcenter Width		
	4'	5'	6'
Plastic Laminate	385-4P	385-5P	385-6P
ESD (Anti-Static)	385-4C	385-5C	385-6C
Laminated Maple	385-4W	385-5W	385-6W
Hardwood	385-4B	385-5B	385-6B
12 Gauge Steel	385-4T	385-5T	385-6T
Hardboard on Steel	385-4M	385-5M	385-6M

One cabinet with one drawer 4¹/₂"H; four drawers 6"H. One cabinet with two drawers 3"H; one drawer 4¹/₂"H; one drawer 6"H; one 12"H hanging file drawer. Bottom shelf on all workcenters. All units complete with cabinet locks.



386 Series

Work Surface Type	Workcenter Width		
	4'	5'	6'
Plastic Laminate	386R4P	386R5P	386R6P
ESD (Anti-Static)	386R4C	386R5C	386R6C
Hardwood	386R4W	386R5W	386R6W
Bonded Wood	386R4B	386R5B	386R6B
12 Gauge Steel	386R4T	386R5T	386R6T
Hardboard on Steel	386R4M	386R5M	386R6M

Left hand cabinet with one drawer 3"H; three drawers 4¹/₂"H; two drawers 6"H. Right hand cabinet with one drawer 4¹/₂"H; one door 24"H with one interior adjustable shelf. All units complete with door and cabinet locks. To order unit with cabinet reversed from right to left, change letter in catalog number from "R" to "L".



387 Series

Work Surface Type	Workcenter Width		
	4'	5'	6'
Plastic Laminate	387R4P	387R5P	387R6P
ESD (Anti-Static)	387R4C	387R5C	387R6C
Hardwood	387R4W	387R5W	387R6W
Bonded Wood	387R4B	387R5B	387R6B
12 Gauge Steel	387R4T	387R5T	387R6T
Hardboard on Steel	387R4M	387R5M	387R6M

One cabinet with one 3"H drawer; three 4¹/₂"H drawers; one 12"H hanging file drawer. Pedestal leg with UL approved fused electrical outlets. Bottom shelf on all workcenters. All units complete with cabinet lock. To order unit with cabinets reversed right to left, change letter in catalog number from "R" to "L".



388 Series

Work Surface Type	Workcenter Width		
	4'	5'	6'
Plastic Laminate	388-4P	388-5P	388-6P
ESD (Anti-Static)	388-4C	388-5C	388-6C
Hardwood	388-4W	388-5W	388-6W
Bonded Wood	388-4B	388-5B	388-6B
12 Gauge Steel	388-4T	388-5T	388-6T
Hardboard on Steel	388-4M	388-5M	388-6M

With two pedestal legs with UL approved fused electrical outlets. Bottom shelf and modesty panel on all workcenters.



389 Series

Work Surface Type	Workcenter Width		
	4'	5'	6'
Plastic Laminate	389R4P	389R5P	389R6P
ESD (Anti-Static)	389R4C	389R5C	389R6C
Hardwood	389R4W	389R5W	389R6W
Bonded Wood	389R4B	389R5B	389R6B

Left hand cabinet with one 4¹/₂"H drawer; two 6"H drawers; one 12"H door. Right hand cabinet with one full height 28¹/₂"H door with one adjustable interior shelf. To order unit with cabinets reversed right to left, change letter in catalog number from "R" to "L". Bottom shelf and 12"H plastic laminate aerial shelf with UL approved fused electrical outlet riser supports on all workcenters. (ESD (Anti-Static) top workcenter is furnished with ESD (Anti-Static) aerial shelf. To order steel aerial shelf, as shown, refer to accessories, page 119.)

Workcenters & Workbenches

Equiptoflex Workcenter - Accessories

15" wide cabinets compliment your Equipto drawers by adding convenience and flexibility. Use them individually, on wheels or as flexible technical workcenters.

5th Add optional accessories.

Design your own Equipto workcenter



1st Select cabinet frames and/or pedestal legs. Frames for 15" wide cabinets

Right Hand Bench Cabinet

Height	No Lock	Top Lock	Points.
33 ¹ / ₂ "	487NLR	487TLR	95
29"	486NLR	486TLR	80
24 ¹ / ₂ "	485NLR	485TLR	65

Left Hand Bench Cabinet

Height	No Lock	Top Lock	Points.
33 ¹ / ₂ "	487NLL	487TLL	95
29"	486NLL	486TLL	80
24 ¹ / ₂ "	485NLL	485TLL	65

Free Standing Cabinet (Not used with workcenter)

Height	No Lock	Top Lock	Points.
33 ¹ / ₂ "	487NLE	487TLE	95
29"	486NLE	486TLE	80
24 ¹ / ₂ "	485NLE	485TLE	65

Above units include leveling feet, and are 27³/₄" Deep
Caster kit available - #231

Pedestal legs (3" w)

Height	With		Without	
	Electric Outlets	Without Electric Outlets	Electric Outlets	Without Electric Outlets
24 ¹ / ₂ "	495EL	495NE	495EL	495NE
29"	496EL	496NE	496EL	496NE
33 ¹ / ₂ "	497EL	497NE	497EL	497NE



Includes leveling feet. Equipto workcenter with 2 pedestal legs requires Steel Modesty Panel.

2nd Fill cabinet frames with doors or drawers

Drawer Height	Part No.	Useable Height	Points
3"	541-10	2 ⁹ / ₁₆ "	10
4 ¹ / ₂ "	542-15	4 ¹ / ₁₆ "	15
6"	543-20	5 ⁹ / ₁₆ "	20
12"	547-40	11 ⁹ / ₁₆ "	40
Door Height	Part No.	Useable Height	Points
12"	550L40*	12"	40
	550R40		
19 ¹ / ₂ "	553L65*	19 ¹ / ₂ "	65
	553R65		
24"	554L80*	24"	80
	554R80		
28 ¹ / ₂ "	555L95*	28 ¹ / ₂ "	95
	555R95		

* L & R indicate which side of cabinet has door hinge. The sum of the last 2 digits of the drawer/door selection must total the number of points associated with each cabinet size. Ex: 4 - #543-20 have 4 x 20 = 80 points, which fills cabinet #486. Inside dimensions of drawers are 12" W x 25" D. Clear height 7¹/₁₆" less than nominal height.

Note: Spacer channel #9240 is required at top of cabinet when any steel top is used. Full cabinet height door may not be used.

3rd Add lower recessed shelf or panel (required).

Recessed lower shelf

For Use in Equiptoflex workcenter:

Width	Two Cabinets	One Cabinet & One Leg	Two Legs
4'	470T4	471T4	472T4
5'	470T5	471T5	472T5
6'	470T6	471T6	472T6

Full Height Modesty Panels

Height	Width	Part No.
24" H	4'	476-4
	5'	476-5
	6'	476-6
29" H	4'	477-4
	5'	477-5
	6'	477-6
33" H	4'	478-4
	5'	478-5
	6'	478-6



Aerial shelf assembly (2 riser supports, shelf and back panel).

Type of Shelf

	Wood		Steel		Conductive		Plastic Laminate	
	w/elec.	w/o elec.	w/elec.	w/o elec.	w/elec.	w/o elec.	w/elec.	w/o elec.
14" High (depth of top surface is 13¹/₂")								
4'	464W4	466W4	464T4	466T4	464C4	466C4	464P4	466P4
5'	464W5	466W5	464T5	466T5	464C5	466C5	464P5	466P5
6'	464W6	466W6	464T6	466T6	464C6	466C6	464P6	466P6
7'	464W7	466W7	464T7	466T7	464C7	466C7	464P7	466P7
3'								466P3
90"			464T90					
24" High (depth of top surface is 16¹/₂")								
4'	467W4	469W4	467T4	469T4	467C4	469C4	467P4	469P4
5'	467W5	469W5	467T5	469T5	467C5	469C5	467P5	469P5
6'	467W6	469W6	467T6	469T6	467C6	469C6	467P6	469P6
7'	467W7	469W7	467T7	469T7	467C7	469C7	467P7	469P7
3'			859122					
8'			850696T8					

Add "W" to the end of the part number for wire back grid panel. (Available only in 14" height)

Note: Units with electrical include power in both left and right aerial shelf riser supports.

4th Select work surface - 30" Deep

Tops

Style	Length	30" Deep
Steel Top	4'	441U4
(12 gauge)*	5'	441U5
With Backstop	6'	441U6
Hardboard	4'	441U4M
On Steel,	5'	441U5M
With Backstop	6'	441U6M
Bonded	4'	441-4B
Wood,	5'	441-5B
1 ³ / ₄ " thick	6'	441-6B
Laminated	4'	441-4W
Hardwood	5'	441-5W
1 ³ / ₄ " thick	6'	441-6W
ESD (Anti-Static)	4'	441-4C
1 ¹ / ₄ " thick	5'	441-5C
	6'	441-6C
Laminated	4'	441-4P
Plastic,	5'	441-5P
1 ¹ / ₄ " thick	6'	441-6P

*Note-Spacer channel #9240 is required at top of cabinet when any steel top is used.

Gray cloth tackboard for aerial shelf

Back panel				
Width	4'	5'	6'	7'
14" High	538-4	538-5	538-6	538-7
24" High	517210A	517211A	517212A	517213A

Do not less out steel back panel.

Steel monitor risers

Sturdy **Steel Monitor Risers** elevate computer monitor above work area and create space for keyboard when not in use. Risers have soft rubber feet to eliminate marking desktops and can be painted to match Equipto workstation. Available in two sizes.

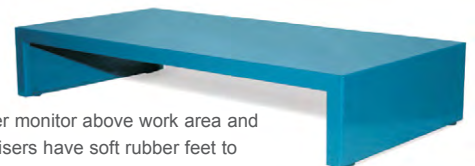

Part No.	Dimensions
310	12" D x 12" W x 4 ¹ / ₂ " H
311	12" D x 24 ¹ / ₂ " W x 4 ¹ / ₂ " H

Drawer dividers (left to right)

Drawer Height	Part No.
3"	8891
4 1/2"	8892
6"	8893

Accessories

Pullout Keyboard Tray (for computer keyboard)	537
Cabinet unit lock	3101
Door lock	3103
Adjustable shelf	539-05
1 1/2" spacer strip (for use with flange down steel tops)	540-05
3" High Mobile Wheel kit (mobilizes any Equiptoflex cabinet)	4406
Task Light (for under aerial shelf)	307
Spacer (for steel top)	9240
Paper label	224995
Mylar label cover	224994
Plastic end caps for handles (left)	993102L
Plastic end caps for handles (right)	993102R

Special Components

Aerial Shelf Riser Support Tower, 3"W x 14"H x 12"D w/o Outlets	480NE
Aerial Shelf Riser Support Tower, 3"W x 14"H x 12"D w/ Outlets	480EL
Aerial Shelf Riser Support Tower, 3"W x 24"H x 15"D w/o Outlets	481NE
Aerial Shelf Riser Support Tower, 3"W x 24"H x 15"D w/o Outlets	481EL
30"W x 13-1/2"D Steel Top (add (4) of each 13162 &13060)	6155
36"W x 13-1/2"D Steel Top (add (4) of each 13162 &13060)	6156
8"W x 24"H x 16-1/2"D Aerial with electric, No Top	467-8
8"W x 13-1/2"D Steel Top (hardware included)	850696
8"W x 16-1/2"D Steel Top (add (4) of each 13162 &13060)	850696-7A
8"W x 13-1/2"D Wood Top (add (4) of 13156)	859096W
8"W x 16-1/2"D Wood Top (add (4) of 13156)	8590204
48-7/8"W x 13-1/2"D Steel Back Panel for 54"W aerial (add (4) of each 13162 &13060)	859054
54"W x 13-1/2"D Tack Board	9120006-002
54"W x 13-1/2"D Plastic Laminate Top (add (4) of 13156)	9111754-002

Aerial Shelf Back Panel Options to Change Solid Back to Pegboard or Stainless Steel

Less Out Qty	Width	Part	Qty	Width	Painted Peg Board Back	SS Peg Board Back	SS Solid Back Panel
14"H Aerial – Less Out Solid Panel			14"H Aerial – Add in Replacement Option				
-1	4'	517175F	1	4'	517175F-PEG	N/A	N/A
-1	5'	517176F	1	5'	517176F-PEG	N/A	N/A
-1	6'	517177F	1	6'	517177F-PEG	N/A	N/A
-1	8'	517178F	1	8'	517178F-PEG	N/A	N/A
24"H Aerial – Less Out Solid Panel			24"H Aerial – Add in Replacement Option				
-1	4'	517275F	1	4'	517275F-PEG	517275FSH	517275FS
-1	5'	517276F	1	5'	517276F-PEG	517276FSH	517276FS
-1	6'	517277F	1	6'	517277F-PEG	517277FSH	517277FS
-1	8'	517278F	1	8'	517278F-PEG	N/A	N/A

Note: Must have an aerial shelf part number included in parts list already; these parts are just to change the back panel and will not come with the actual complete aerial.



Storage Cabinets

Storage Cabinets

Flammable Liquid Storage Cabinets

Protect your personnel and your business

- Galvanized steel shelves and leveling legs
- Support up to 350 lbs.
- Internal and external welded construction
- 18 gauge steel reinforced double wall panel construction
- 2" raised leakproof sill
- 2" vent with fire baffle and cap
- Ground connection
- Lead-free high gloss baked on powder finish
- 3 point key lock doors
- Meet OSHA and NFPA code 30 specifications
- Self-closing models meet UFC 79, fusible links, melt at 165°
- Seismic kits also available



shipped assembled

Equipto flammable liquid cabinets help protect you from fire hazard. Use them for volatile liquids that need to be safely contained like:

- Alcohol
- Acetone
- Formaldehyde
- Gasoline



These cabinets can be conveniently placed wherever safe housekeeping procedures or ease of accessibility dictate.



Part No.	Description	Dimensions (W X D X H)	Weight
FSC15S	15 gal two door self-closing	43" x 18" x 24"	145 lbs.
FSC15M	15 gal two door manual close	43" x 18" x 24"	135 lbs.
FSC30M	30 gal two door, one shelf, manual close	43" x 18" x 44"	247 lbs.
FSC30S	30 gal two door, one shelf, self-closing	43" x 18" x 44"	257 lbs.
FSC45M	45 gal two door, two shelves, manual close	43" x 18" x 65"	342 lbs.
FSC45S	45 gal two door, two shelves, self-closing	43" x 18" x 65"	353 lbs.
FSC60M	60 gal two door, two shelves, manual close	34"x 34" x 65"	354 lbs.
FSC60S	60 gal two door, two shelves, self-closing	34"x 34" x 65"	364 lbs.
FSC90M	90 gal two door, two shelves, manual close	43" x 34" x 65"	465 lbs.
FSC90S	90 gal two door, two shelves, self-closing	43" x 34" x 65"	475 lbs.
FSCSHELF	*Additional Shelf	43" x 18"	12 lbs.
FSC60SHELF	*Additional Shelf	31 ¹ / ₄ " x 31 ¹ / ₄ "	12 lbs.

*(2) shelves are needed per required additional shelf when adding to a 34"D x 43"W cabinet

Flammable liquid storage cabinets are safety yellow.

Storage Cabinets

Equipto storage cabinets feature a rugged construction and attractive design that make them perfect for any environment from shop to office. Choose from desk, counter and full height configurations to fit your exact requirement.

Cabinets are shipped knocked down, assembly required.



Door latch

Cabinet doors are equipped with a durable safety latch which allows smooth, quiet operation. All doors open with ease, yet close securely.



Cabinet frames

Crafted of sturdy steel, cabinet frames feature an advanced interlocking design for maximum strength and superior rigidity.



Door handles

Attractively designed handles are made of satin, chrome-plated steel. A 3-point locking device on door assures secure storage of contents.



Positive shelf lock

All shelves have a positive lock which slides into the opening and locks in place. Even with rugged use, cabinet shelves cannot be dislodged.



Three-point latches for security

Rigid frames and sturdy hinges.

Heavy gauge steel construction.

Smooth surfaces and graceful contours mean no protrusions to snag clothing.

Cabinet doors are reinforced.

Each unit is level and completely balanced.

Bases are recessed.

A standard color chart is available on page 150.

Storage Cabinets

22 ga steel; 2 keys included; shelf capacity 200lbs.



1714/1719

Combination Cabinet

Versatile unit with 5 shelves plus wardrobe area with rod and 4 hooks. Divider panel permits locating wardrobe on either side. Locking handles and key. **Extra shelves can be added.**



1712/1717

Wardrobe Cabinet

Spacious cabinet has a sturdy, metal rod and 4 hooks for hanging coats, plus a top shelf for personal items. Locking handles and key.



1710/1715

Spacious Cabinet

Rugged cabinet in 2 depths features locking handles and key and 4 adjustable shelves (2" centers). **Extra shelves can be added.**



1700/1705

Counter High Cabinet

Double-door cabinet has locking handles and 2 interior shelves. Use back-to-back; side-by-side; add extra shelves.

Available in two depths.

*Not wall-mounted



1730

Desk High Cabinet

Use back-to-back or side-by-side to form a credenza. Has 1 shelf, locking handles. Add extra shelves to expand space.



1730WS

Book Shelf Cabinet

Combination unit with 2 adjustable shelves (3/4" centers) and 2 door cabinet with internal shelf and locking handles.



1734/1735

Wall Hung Cabinet

Keeps books, manuals, parts. Locking handle.

Shipped set-up. Order part number

1734DI/1735DI if it's required to have the handles located lower on the cabinet.

Cabinet		Size			Extra Shelves	
Part No.	Description	Width	Depth	Height	Part No.	Shelf Capacity
1712	Wardrobe	36"	18"	78"	--	200 lbs.
1717	Wardrobe	36"	24"	78"	--	225 lbs.
1710	5-shelf	36"	18"	78"	16027A	200 lbs.
1715	5-shelf	36"	24"	78"	16029A	225 lbs.
1734*	2-shelf	30"	13"	27"	16017	200 lbs.
1734DI*	2 shelf upper cabinet	30"	13"	27"	16017	200 lbs.
1735*	2-shelf	36"	13"	27"	16025	200 lbs.
1735DI*	2 shelf upper cabinet	36"	13"	27"	16025	200 lbs.
1730WS	Book Shelf/Cabinet	36"	18"	71"	6192 (Upper) 16027A (Lower)	200 lbs.
1714	Combination	36"	18"	78"	16032A	200 lbs.
1719	Combination	36"	24"	78"	16033A	225 lbs.
1700	Counter High	36"	18"	42"	16027A	200 lbs.
1705	Counter High	36"	24"	42"	16029A	225 lbs.
1730	Desk High	36"	18"	29"	16027A	200 lbs.
11245	Locking Handle					
11245KA	Locking Handle Keyed Alike					
11245M	Master Key					
11246	Rigid Handle					
10428	Key					

All cabinets shipped unassembled. *Wall-mounted units shipped assembled (no UPS)

A standard color chart is available on page 150.

Quick-View Storage Cabinets

Part No.	Description	Width	Depth	Height	Additional Shelf
QVC301226SU	Wall Hung QVS Cabinet	30"	12"	26"	514-1240
QVC361842	QVS Cabinet	36"	18"	42"	514-1836
QVC361878	QVS Cabinet	36"	18"	78"	514-1836
QVC362478	QVS Cabinet	36"	24"	78"	514-2436
QVC482478	QVS Cabinet	48"	24"	78"	514-2448

*SU=set up. You may order an assembled unit upon request by adding a "SU" to the end of the part no. (an additional fee will apply). Shelves do not require separate hardware.



Equipto Quick-View Cabinets are designed for both easy visibility and security of personal belongings, books, files, equipment supplies parts, etc. Clean styling and durable construction make these cabinets ideal for both office and industrial environments.

Features:

- UV, break and scratch resistant plastic Lexan panels are mounted in both door frames for an unobstructed view of the cabinet's contents.
- Each shelf has a 225 lb. weight capacity with 2" increment height adjustability.
- Cabinet doors have a 3-point locking mechanism with one chrome plated handle. (2 keys)
- Multiple cabinets will be keyed alike
- Dollies are available for the 78" high cabinets to add mobility

NEW!

Quick-View Bin Cabinet



Cabinet with custom bin and shelf layout

Equipto Quick-View Storage Cabinets offer the perfect appearance, capacity, visibility and security for your plant or office.

Dollies

Part No.	Description (W x D)
CD1836	Dolly for 36" x 18" Cabinet
CD2436	Dolly for 36" x 24" Cabinet
CD2448	Dolly for 48" x 24" Cabinet



Quick View Storage Cabinets with Bins

Part Number	Description
QVC361878LPBC-001	QVC361878LP-001 with a back cover and 66 plastic bins
QVC361878LP-001	Cabinet fully loaded with 66 050-0230 bins without back cover
QVC361878LP	Cabinet with louver back panel, no bins or shelf
QVC361878LPBC	QVC361878LP with a back cover

Add SU to end of part number for assembled unit, i.e. QVC361878LP-001SU

Individual Parts

Part Number	Description
090-4885	Louver back panel
090-4886	Back cover to conceal louver holes
514-1836	Shelf

Individual Bins

Part Number	Description	Bins required to fill cabinet
050-0200Y	5" x 4-1/8" x 3" 8lb capacity bin	136
050-0220Y	7-3/8" x 4-1/8" x 3" 10lb capacity bin	136
050-0230Y	10-1/2" x 5-1/2" x 5" 30lb capacity bin	72

NEW!

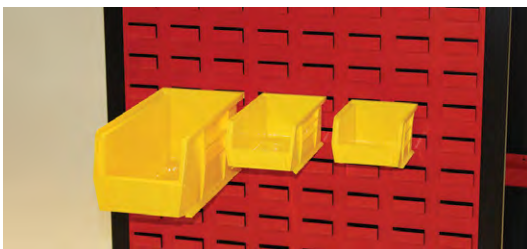

050-0230Y 050-0220Y 050-0200Y

A standard color chart is available on page 150.

Mobile Computer Cabinet

Equipto Mobile Computer Cabinets are designed to provide maximum protection for computer equipment from dust, metal shards and other debris. The locking, mobile cabinet keeps your expensive computer equipment clean and safe.

The Mobile Computer Cabinet is ideal for PCs, terminals and other computer peripherals on the shop floor, in any industrial environment, or where security issues are involved.

Outstanding features include:

- Front and back key-locked doors provide security while allowing easy equipment access to authorized personnel.
- Full door seals to keep dust, metal shards and other debris away from your equipment.
- Easy station-to-station mobility on four heavy-duty casters.
- Built-in fan and louvers for temperature control.
- Lockable slide-out keyboard and mouse tray.
- Heavy-duty slide-out printer shelf.

Features:

- A) Scratch-resistant lexan monitor window
- B) Adjustable monitor shelf can hold up to a 21" monitor
- C) Lockable slide-out keyboard and mouse tray
- D) Adjustable slide-out printer shelf
- E) Accommodates desktop or full-size tower pc
- F) Sealed access doors to keep out dust and debris
- G) Louvers for increased air flow
- H) Full size lockable rear access door for easy accessibility
- I) 2 rigid & 2 swivel casters for easy mobility
- J) Built in air-intake fan with filter

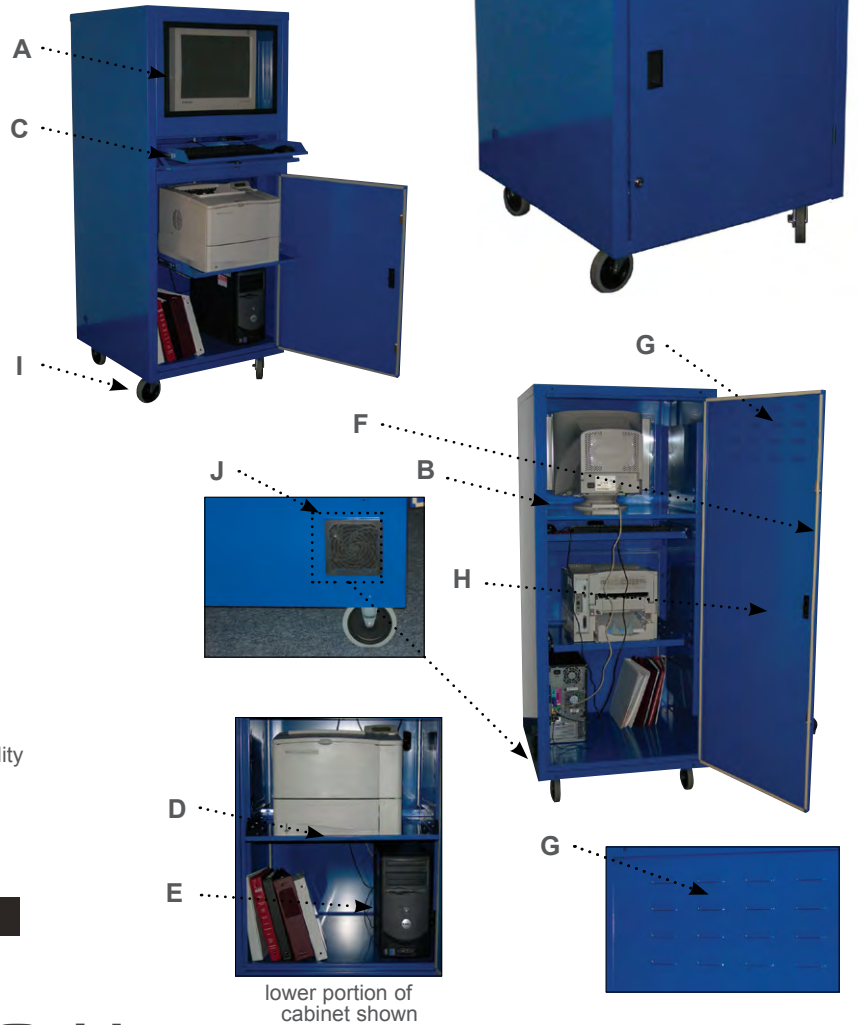

Part No.	Dimensions
ECWS-303069	30"W x 30"D x 69"H

Special Computer Cabinet

Part No.	Dimensions
1-4409	30"W x 273/4"D x 44"H Housing – 130 points
1-4404	Mobile Kit with Handle
2-4403RO	30"W Rollout Shelf
1-4403C	30"W Concealed Shelf
1-4197-28	281/2"H Lockable Swinging Door – 95 points
1-ROSD30-35	30"W Special Rollout Shelf with Lockable Dropdown Door – 35 points

Armadillo Cabinet Line

Equipto's Industrial Cabinet Line provides you with the ultimate in Heavy Duty 12 Gauge Cabinets. All Armadillo cabinets are Armadillo dark gray in color.

Each cabinet includes:

- 14 gauge shelves with up to 1900 lb. capacity
- Adjustable shelves 2" increments
- Handle includes a hasp for use with padlock
- 7 gauge welded legs for moving and durability
- More shelves can be added for versatility

Heavy Duty Standard Cabinets

- Heavy Duty, 12 gauge Steel, all welded design, specifically for industrial applications

Part No.	Dimensions (W x D x H)	Overall Height	Shelves	Shelf P/N	Capacity	Weight
ICL24132*	36" x 24" x 66"	66"	3	ICS8241	1900	406 lbs.
ICL25103	36" x 20" x 78"	78"	4	ICS8251	1600	435 lbs.
ICL25133	36" x 24" x 78"	78"	4	ICS8241	1900	475 lbs.
ICL34132*	48" x 24" x 66"	66"	3	ICS8341	1200	489 lbs.
ICL35133	48" x 24" x 78"	78"	4	ICS8341	1200	573 lbs.
ICL44132*	60" x 24" x 66"	66"	3	ICS8441	1650	595 lbs.
ICL45133	60" x 24" x 78"	78"	4	ICS8441	1650 <td 699 lbs.	
ICL54132*	72" x 24" x 78"	78"	3	ICS8551	1525	726 lbs.
ICL55133	72" x 24" x 78"	78"	4	ICS8551	1525	856 lbs.

*Casters Optional - (Add CSTR suffix to part number)

Half and Half Cabinet

- Easily separate your items on shelves or in drawers
- Cabinet shelves can be adjusted in 2" increments to accommodate both large and small items

Part No.	Dimensions (W x D x H)	Overall Height	Shelf P/N	Shelf Capacity	Drawer Width	Drawer Capacity	Weight
ICL3513354	48" x 24" x 78"	78"	ICS8342	1125	19"	225	917 lbs.
ICL4513354	60" x 24" x 78"	78"	ICS8442	1575	25"	225	1,079 lbs.
ICL5513354	72" x 24" x 78"	78"	ICS8552	1450	31"	225	1,267 lbs.

Dual Zone Cabinet

- Provides you with two separate shelving compartments
- Both sides can be locked independently; while one side is locked you can work out of the other
- Perfect for two people

Part No.	Dimensions (W x D x H)	Overall Height	Shelf P/N	Adjustable Shelves Each Side	Capacity	Weight
ICL25137	36" x 24" x 78"	78"	ICS8243	4	950	544 lbs.
ICL35137	48" x 24" x 78"	78"	ICS8343	4	1275	642 lbs.
ICL45137	60" x 24" x 78"	78"	ICS8443	4	1600	740 lbs.
ICL55137	72" x 24" x 78"	78"	ICS8553	4	1950	838 lbs.

Built to last

- 12 gauge steel one piece wrap around shell
- 12 gauge steel doors
- 12 gauge steel bottom
- 14 gauge steel shelves attached with 3/8" carriage bolts
- 8 gauge hinge leaf, 5/16" brass hinge pin, 3/4" receiver
- cast aluminum bronze alloy handle, 3/8" angle receiver with three point locking device, 3/8" latch rod, 3/16" latch plate
- 3/16" steel legs, provision for lagging, 6" sweep space

Units are all welded, and fully assembled.



Every unit comes fully assembled
Standard paint is Armadillo dark gray water based application

Bin Cabinets

Heavy Duty, 12 gauge Steel, all welded design, specifically for industrial applications.

4 Shelf Bin Cabinet with adjustable shelves

With the introduction of Bin Storage to our Shelving cabinets, you are now able to store both large and small items all in a single cabinet. Bins are 4^{1/4}" wide, 7^{3/8}" deep and 3" high and constructed of Polypropylene.

Part No.	Dimensions (W x D x H)	Overall Height	Number of Small Bins	Shelf P/N	Shelf Capacity	Weight
ICLB710	36" x 24" x 78"	78"	94	ICS8742	1350	533 lbs.
ICLB720	48" x 24" x 78"	78"	144	ICS8822	850	651 lbs.

It is recommended that these cabinets be anchored to your floor or wall.



Total Bin Cabinet

Packed with 32 Large Bins holding up to 60 lbs. each, large bins are 8^{1/4}" wide by 14^{3/4}" deep and 7" high. There are 94 Small Bins which hold up to 10 lbs. each and comes completely assembled. Small bins are 4^{1/4}" wide, 7^{3/8}" deep and 3" high and constructed of Polypropylene.

Part No.	Dimensions (W x D x H)	Overall Height	Number of Small Bins	Number of Large Bins	Weight
ICLB730	36" x 24" x 78"	78"	94	32	596 lbs.
ICLB740	48" x 24" x 78"	78"	144	40	732 lbs.



3 Shelf Total Bin Cabinet

Enjoy the storage of the Total Bin Cabinet with the flexibility of 3 adjustable shelves. Small bins are 4^{1/4}" wide, 7^{3/8}" deep and 3" high and constructed of Polypropylene. Large bins are 8^{1/4}" wide, 14^{3/4}" deep and 7" high.

Part No.	Dimensions (W x D x H)	Overall Height	Number of Small Bins	Number of Large Bins	Shelf P/N	Shelf Capacity	Weight
ICLB750	36" x 24" x 78"	78"	94	16	ICS8742	1350	579 lbs.
ICLB760	48" x 24" x 78"	78"	144	20	ICS8822	850	756 lbs.



Storage Cabinets

Every unit comes fully assembled
Standard paint is Armadillo dark gray water based application

Janitorial/Locker Cabinets

Standard Janitorial/Locker Cabinet

Provides you with two storage compartments, one for clothing and the other for materials and tools.



Part No.	Dimensions (W x D x H)	Overall Height	Closet Shelves	Closet Shelf P/N	Closet Shelf Capacity	Hanger Shelf P/N	Hanger Shelf Capacity	Weight
ICLJ551250	36" x 24" x 78"	78"	4	ICCS8244	1100	ICHS8245	775	501 lbs.
ICLJ551260	48" x 24" x 78"	78"	4	ICCS8344	1500	ICHS8345	1050	594 lbs.
ICLJ551270	60" x 24" x 78"	78"	4	ICCS8444	1900	ICHS8645	1300	687 lbs.

Dual Zone Janitorial/Locker Cabinet

Provides you with two separate storage compartments which can be opened and locked independently.



Part No.	Dimensions (W x D x H)	Overall Height	Closet Shelves	Closet Shelf P/N	Closet Shelf Capacity	Hanger Shelves	Hanger Shelf P/N	Hanger Shelf Capacity	Weight
ICLJ551300	72" x 24" x 78"	78"	8	ICCS8244	1025	2	ICHS8445	825	893 lbs.

Full Length Janitorial/Locker Cabinet

Heading out to the job or heading home for the day? Store your personal and work items in one cabinet.

Part No.	Dimensions (W x D x H)	Overall Height	Shelf P/N	Shelf Capacity	Weight
ICLJ551280	36" x 24" x 78"	78"	ICS8246	1900	421 lbs.
ICLJ551290	48" x 24" x 78"	78"	ICS8346	1200	500 lbs.



Every unit comes fully assembled
Standard paint is Armadillo dark gray water based application

Janitorial Broom Side Closet

Store those housekeeping and items with long handles out of the way. Also store any other materials like cleaners, brushes, or tool chests on the adjustable shelves of the other side

No locking handle. Padlock only.



Part No.	Dimensions (W x D x H)	Overall Height	Closet Shelves	Shelf P/N	Shelf Capacity	Weight
ICLJ551310	36" x 24" x 78"	78"	4	ICCS8244	1025	492 lbs.
ICLJ551320	48" x 24" x 78"	78"	4	ICCS8344	1375	580 lbs.
ICLJ551330	60" x 24" x 78"	78"	4	ICCS8444	1750	659 lbs.
ICLJ551340	72" x 24" x 78"	78"	4	ICCS8544	1050	766 lbs.

Tool Crib Cabinet

Two separate sections to store all your tool needs. Up top you have 3 adjustable shelves, two of which are slotted with metal vertical dividers. The lower section has a 14 gauge adjustable shelf. Separating the two section is a 12" deep shelf which can be used to do work on or repair tools.



Part No.	Dimensions (W x D x H)	Overall Height	Standard Shelf P/N	Standard Shelf Capacity	Slotted Shelf P/N	Slotted Shelf Capacity	Dividers/ Slotted Shelf	Weight
ICLTC551350	36" x 24" x 78"	78"	ICS8241	1900	ICSS8246	1425	3	509 lbs.
ICLTC551360	48" x 24" x 78"	78"	ICS8341	1200	ICSS8346	900	4	637 lbs.
ICLTC551370	60" x 24" x 78"	78"	ICS8441	1650	ICSS8446	1225	5	767 lbs.

Storage Cabinets

Every unit comes fully assembled
Standard paint is Armadillo dark gray water based application

Bench Cabinets

Rugged bench cabinets are available in 15", 21 1/2" and 30" widths and provide convenient workspace and storage for tools and parts. Choose between mobile and stationary configurations as well as a variety of tops to suit your application.

- Rugged welded frame cabinets for small spaces
- Stationary or portable
- Secure shelf space or drawer space with a bench top in as little as 15" wide
- Back rail
- Four-drawer unit
- Single-door unit
- Roller suspension drawers

Bench cabinets - 15" wide



240DS



245DS



240DP



245DP

240 Series with Door and Shelf

Caster Capacity	Steel Tops		Hardboard on Steel	
	With Backstop	Without Backstop	With Backstop	Without Backstop
15"W x 24 7/8"D x 34"H				
500 lb.	240UP	240DP	240UPM	240DPM
No Casters	240US	240DS	240USM	240DSM

245 Series with Drawers

Caster Capacity	Steel Tops		Hardboard on Steel	
	With Backstop	Without Backstop	With Backstop	Without Backstop
15"W x 24 7/8"D x 34"H				
500 lb.	245UP	245DP	245UPM	245DPM
No Casters	245US	245DS	245USM	245DSM

Bench cabinets - 15" & 21 1/2" W



221SW5

223SW4

- Equipto mobile drawer cabinets enable faster delivery of parts and supplies right to the job site. Compact, efficient and designed to save you time.
- 4 and 5 drawer units available
- Rigid steel construction
- Use stationary or as mobile units
- Roller suspension drawers
- Optional items:
 - Loop handle (#11574)
 - Tumbler locks (#10405)
 - Tumbler locks keyed alike (#10405KA)
 - Padlock cover (#11216)

Part No.	Description	Drawer Size (W x D x H)	Cabinet Size (W x D x H)	Load Capacity
223MW4	4-drawer w/hardboard top	21 1/2" x 23 3/4" x 7 3/4"	21 1/2" x 22 3/4" x 37 1/2"	500 lbs.
223SW4	4-drawer w/steel top	21 1/2" x 23 3/4" x 7 3/4"	21 1/2" x 22 3/4" x 37 1/2"	500 lbs.
221MW5	5-drawer w/hardboard top	15" x 23 3/4" x 6 1/4"	15" x 22 3/4" x 37 3/4"	500 lbs.
221SW5	5-drawer w/steel top	15" x 23 3/4" x 6 1/4"	15" x 22 3/4" x 37 3/4"	500 lbs.

A standard color chart is available on page 150.

Bench cabinets - 30" wide x 27³/₄" deep



250-PB



255DP



260-PW

- Stationary or portable
- Back rail available
- Flat or sloped tops
- Roller suspension drawers
- Door cabinets have middle shelf
- Lock It Up! All doors and drawers accept standard padlocks, or order #10405 key locks, keyed either differently or alike

Series	Caster Capacity	Steel Tops		Wood Tops		Hardboard on Steel	
		With Backstop	Without Backstop	Hardwood	Bonded Wood	With Backstop	Without Backstop
250 Series - 2 doors with shelving							
	500 lbs.	250UP	250DP	250-PW	250-PB	250UPM	250DPM
	800 lbs.	250UH	250DH	250-HW	250-HB	250UHM	250DHM
	No Casters	250US	250DS	250-SW	250-SB	250USM	250DSM
255 Series - 1 door with shelf and 4 drawers							
	500 lbs.	255UP	255DP	255-PW	255-PB	255UPM	255DPM
	800 lbs.	255UH	255DH	255-HW	255-HB	255UHM	255DHM
	No Casters	255US	255DS	255-SW	255-SB	255USM	255DSM
260 Series - 8 drawers							
	500 lbs.	260UP	260DP	260-PW	260-PB	260UPM	260DPM
	800 lbs.	260UH	260DH	260-HW	260-HB	260UHM	260DHM
	No Casters	260US	260DS	260-SW	260-SB	260USM	260DSM

Without casters the overall height 34¹/₈"
 With casters, the overall height is 40¹/₈"

NOTE: All units are 30" wide and 27³/₄" deep without top. Tops are 30" wide and 30" deep unless sloping desktop is used which is 30"W x 29"D. Add 1⁵/₈" to overall height if wood top is used, and 6⁷/₈" overall height if sloping desktop is used.

Bench Cabinets with Sloping Desk Top

250 Series	Part No.	255 Series	Part No.	260 Series	Part No.
500 lbs.	250FP	500 lbs.	255FP	500 lbs.	260FP
800 lbs.	250FH	800 lbs.	255FH	800 lbs.	260FH
No Casters	250FS	No Casters	255FS	No Casters	260FS



Aerial Shelf
 A #226-30 Aerial Shelf adds extra capability without sacrificing bench top work space.



Sloping Desk Top
 Top is 30"W x 29"D x 6⁷/₈"H
 Sloping desk top
Part No. 294

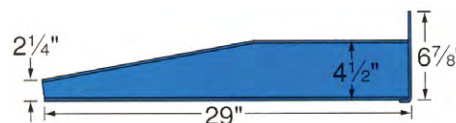

A standard color chart is available on page 150.



Carts

V-Grip™ Shelving Carts

- Instant mobility
- Open wire construction promotes high visibility, letting light and air pass freely
- Rugged and easy to use
- Handles the most demanding jobs
- All units have two brake and two rigid casters
- Casters are not recommended for units over 66"H



Equipto Carts are heavy duty to handle the toughest jobs. For Perimeter Bases see page 17. Handle is standard reflective white.

V-Grip™ wire carts Casters are not recommended for units over 66"H

Depth	Width	Overall Height	Number of Shelves	With Standard Duty Casters (500 lbs. Capacity)	With Heavy Duty Casters (800 lbs. Capacity)	Additional Intermediate Shelves
18" Depth						
36"	42"	42"	2	4573	4573D	6073
		54"	3	4583	4583D	
		66"	4	4593	4593D	
48"	42"	42"	2	4574	4574D	6074
		54"	3	4584	4584D	
		66"	4	4594	4594D	
60"	42"	42"	2	4575	4575D	6075
		54"	3	4585	4585D	
		66"	4	4595	4595D	
72"	42"	42"	2	4576	4576D	6076
		54"	3	4586	4586D	
		66"	4	4596	4596D	
24" Depth						
36"	42"	42"	2	4673	4673D	6083
		54"	3	4683	4683D	
		66"	4	4693	4693D	
48"	42"	42"	2	4674	4674D	6084
		54"	3	4684	4684D	
		66"	4	4694	4694D	
60"	42"	42"	2	4675	4675D	6085
		54"	3	4685	4685D	
		66"	4	4695	4695D	
72"	42"	42"	2	4676	4676D	6086
		54"	3	4686	4686D	
		66"	4	4696	4696D	

A standard color chart is available on page 150.

Carts

- Quality one-piece tray construction, tubular posts and handles
- 4" deep reversible steel trays with beaded edges for extra strength
- Smooth rolling 5" rubber casters two swivel, two fixed
- Optional welded drawer units provide extra capacity
- Ships un-assembled



Width	Length	Height	Trays	Capacity	Drawers			
					A None	B (8)11" Deep	C (18)11" Deep	D (18)17" Deep
16"	30"	36"	2	500 lbs.	145	145-8	--	--
				800 lbs.	145D	145D8	--	--
24"	36"	36"	2	500 lbs.	150	150-8	150-11	150-22
				800 lbs.	150D	150D8	150D11	150D22

Cart heights include casters. Casters are not recommended for carts over 66"

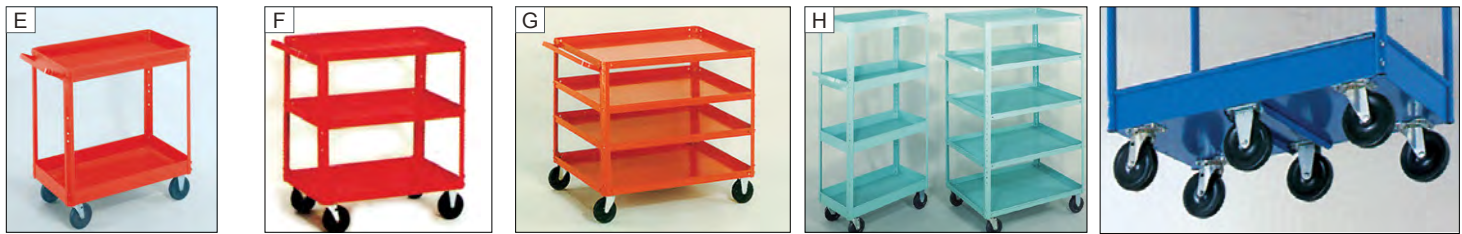

E Two-Tray-33" high

Width	Tray Length	Depth	Capacity	Part No.
16"	30"	3"	500 lbs.	147
24"	36"	3"	500 lbs.	152
16"	30"	3"	800 lbs.	147D
24"	36"	3"	800 lbs.	152D

G Four-Tray-33" high

Width	Tray Length	Depth	Capacity	Part No.
16"	30"	1 ⁹ / ₁₆ "	500 lbs.	155
24"	36"	1 ⁹ / ₁₆ "	500 lbs.	160
16"	30"	1 ⁹ / ₁₆ "	800 lbs.	155D
24"	36"	1 ⁹ / ₁₆ "	800 lbs.	160D

Tight Turn Caster Kit

Capacity	Width	Kit
500 lbs.	16"	158
800 lbs.	16"	158D
500 lbs.	24"	159
800 lbs.	24"	159D

F Three-Tray-33" high

Width	Tray Length	Depth	Capacity	Part No.
16"	30"	1 ⁹ / ₁₆ "	500 lbs.	156
24"	36"	1 ⁹ / ₁₆ "	500 lbs.	161
16"	30"	1 ⁹ / ₁₆ "	800 lbs.	156D
24"	36"	1 ⁹ / ₁₆ "	800 lbs.	161D

H Four and Five-tray-60" high

Shelves	Width	Tray Length	Depth	Capacity	Part No.
4	16"	30"	3"	800 lbs.	163D
4	16"	30"	3"	800 lbs.	163D
4	24"	36"	3"	800 lbs.	165D
4	24"	36"	3"	800 lbs.	165D
5	16"	30"	1 ⁹ / ₁₆ "	800 lbs.	164D
5	16"	30"	1 ⁹ / ₁₆ "	800 lbs.	164D
5	24"	36"	1 ⁹ / ₁₆ "	800 lbs.	166D
5	24"	36"	1 ⁹ / ₁₆ "	800 lbs.	166D

For use in narrow aisles.



J Three-Shelf units

Width	Tray Length	Depth	Part No. Stationary	Part No. w/Casters
18"	24"	1 ⁹ / ₁₆ "	514	514C
16"	30"	1 ⁹ / ₁₆ "	515	515C
24"	36"	1 ⁹ / ₁₆ "	517	517C

I Tool Toter with drawer (61⁴/₄" x 15" x 23³/₄")

No. of Shelves	Width	Shelf Length	Depth	Part No. Stationary	Part No. w/Casters
2	18"	24"	1 ⁹ / ₁₆ "	518	518C
2	24"	36"	1 ⁹ / ₁₆ "	520	520C
2	24"	36"	3"	534	534C
3	18"	24"	1 ⁹ / ₁₆ "	521	521C
3	24"	36"	1 ⁹ / ₁₆ "	523	523C

Handle Part No. 11559

K Two-Shelf units

Width	Tray Length	Depth	Part No. Stationary	Part No. w/Casters
18"	24"	1 ⁹ / ₁₆ "	510	510C
16"	30"	1 ⁹ / ₁₆ "	511	511C
24"	36"	1 ⁹ / ₁₆ "	513	513C
16"	30"	3"	531	531C
24"	36"	3"	533	533C

A standard color chart is available on page 150.

NC Tool Handling System

Equipto presents a simple solution to the handling and organization needs of the modern NC machining center. Here is a specially designed system to speed transfer of costly NC tools, with dollar-saving protection at every step. Watch your turnaround time drop and machine downtime practically disappear with these sensible integrated components.

- Speeds your work flow as it protects your NC tool investment
- High-capacity, unitized steel frame with rugged handle
- 800 lb tool capacity
- Pre-set tools can be kept in their programmed sequence at all times
- Accessory end trays and shelf units provide space for auxiliary tools and supplies
- Recessed and angled tray handles for easy loading retrieval
- Everything is in clear view, organized and accessible
- NC tool trays can be secured in modular drawer cabinets or shelf units
- Transport to and from machining centers, sharpening/calibration stations, and tool rooms is simpler, safer and more efficient
- Two integral pallet channels permit easy fork truck handling of cart, empty or loaded
- Big, 5" wheels (two swivel, two stationary) allow smooth rolling on any surface



NC Tool Trays

Width	Depth	Taper	w/Brackets	w/o Brackets	Use with
25"	6 1/4"	less than 60	4109	4108	30"W cabinets & carts
25"	7 3/4"	60	4139	4138	30"W cabinets & carts
32"	6 1/4"	less than 60	4109-36	4108-36	36"W carts, shelving or drawers
32"	7 3/4"	60	4139-36	4138-36	36"W carts, shelving or drawers

Support brackets (pair) Part No. 7666-2

Color	Size	To Fit (Shank)	Max. No. Per Tray	Part No.
Yellow	2 3/8" x 5"	#40 Taper	10	4122
Green	2 3/8" x 5"	#30 Taper	10	4123
Silver	2 3/8" x 5"	40 millimeter	10	4120M40
Light Blue	3 3/4" x 5"	2 1/4" Straight	6	4124
Orange	4 1/2" x 5"	#45 Taper	5	4121
Algae Green	4 1/2" x 5"	50 millimeter	5	4120M50
Hot Pink	4 1/2" x 5"	63 millimeter	5	4120M63
Red	4 1/2" x 5"	#50 Taper	5	4120A
Red	5 5/8" x 6 3/4"	#50 Taper	4	4120*
Olive Green	5 5/8" x 6 3/4"	#60 Taper	4	4132*
Purple	3 3/4" x 5"	2" Straight	6	4125
White	3 3/4" x 5"	1 3/4" Straight	6	4126
Blaze Orange	2 3/8" x 5"	1" Straight	10	4131-01
Ivory	2 3/8" x 5"	Univ. 100	10	4115
Royal Blue	2 3/8" x 5"	Univ. 200	10	4116
Pink	2 3/8" x 5"	32mm	10	4120M32
Gold	2 3/8" x 5"	Univ. 300	10	4117
Brown	3 3/4" x 5"	Univ. 400	6	4118
Black	2 3/8" x 5"	R-8 Taper	10	4119
Gray	3 3/4" x 5"	1 1/2" Straight	6	4131
Bright Orange	5 5/8" x 6 3/4"	QCS-45 Taper	4	4136**
Bright Orange	5 5/8" x 6 3/4"	QCS-50 Taper	4	4137**

* 4120 and 4132 tool holders require 4138 or 4139 tool tray. ** Must use on 7 3/4" D tool trays.

NC Tool Cart

Cart	Tool tray		
Width	Length	w/brackets incl.	Part No.
15"	27"	None	4105
15"	27"	Three	4105-03
15"	27"	Four	4105-04
15"	27"	Five	4105-05
26"	27"	None	4110
26"	27"	Three	4110-03
26"	27"	Four	4110-04
26"	27"	Five	4110-05
15"	33-1/4"	None	4105-36
26"	33-1/4"	None	4110-36



Card/Document Holder

Part No. 10115 - 12 3/8" x 16" x 7/8"

End Tray

Two shelf unit attaches to end of cart; shelf bottoms lined with rubber matting to protect tools.

Part No. 4111 - 14" W x 10" D for #4105 cart

Part No. 4112 - 24" W x 10" D for #4110 cart



NC Tool Holders

Precision-molded of high-impact polypropylene, Equipto's shock-absorbing tool holders are virtually indestructible. They fit perfectly in trays, and lock in at a turn of the knurled thumbscrew. Choose straight or tapered shank styles coded in 10 bright identifying colors.



A standard color chart is available on page 150.



Military Storage Systems

CONNEX Modules

An EQUIPTO Connex Module is designed to organize your storage container, however, that does not limit your use. When you are finished using the Connex Module in a storage container, you can easily relocate the Module for additional storage into Bench Stock, Parts Room or a Tool Room.

Once you have decided where to install the Module, EQUIPTO offers endless opportunities to expand your storage horizons. Looking for additional storage capacity in the same area, your Connex Module can evolve into a Deck-over Mezzanine Structure or a High Density Mobile Aisle Storage System.

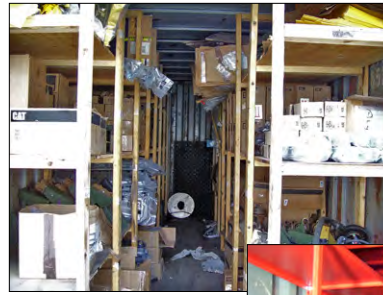

Before



After

All Modules are 20' long with shelving units at a depth of 24" and a height of 90"

CNX-BKS-20

Starter Unit

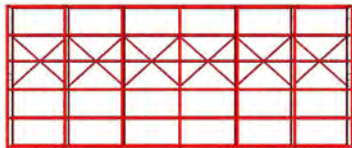

CNX-BKSWC-20

Starter Unit

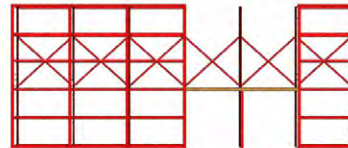

CNX-BKSBR-20

Starter Unit

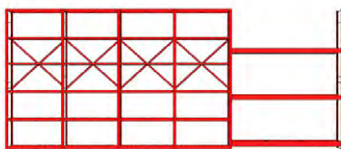

CNX-BKSWCBR-20

Starter Unit

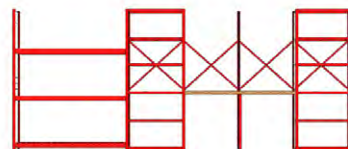

Modules available for both Stationary and Deployable Connex Modules

Images are a rendered version of the final product. Actual product may vary.

A standard color chart is available on page 150.

CONNEX Module Options – Drawers, Doors and Deployment Kits

Enhance your Connex Modules with optional kits and accessory packs.

Under Bench Drawer Packs



CNX-WCDWRK-1S
Drawer sizes included:
(2)3", (2)4.5", 6", 12"



CNX-WCDWRK-2S
Drawer sizes included:
3", (2)4.5", 9", 12"



CNX-WCDWRK-3S
Drawer sizes included:
(2)3", 4.5", 6", 7.5", 9"



CNX-WCDWRK-4S
Drawer sizes included:
(5)3", (4)4.5"



CNX-WCDWRK-5S
Drawer sizes included:
(4)3", (2)4.5", (2)6"



CNX-WCDWRK-6S
Drawer sizes included:
3", 6", (2)12"

Shelving Unit Drawer Packs



CNX-SDWRK-1S
Drawer sizes included:
(2)3", (2)4.5", (2)6", 12"



CNX-SDWRK-2S
Drawer sizes included:
(2)4.5", (5)6"



CNX-SDWRK-3S
Drawer sizes included:
(2)7.5", (2)12"

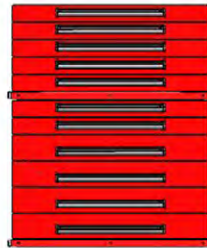

CNX-SDWRK-4S
Drawer sizes included:
(7)3", (4)4.5"



CNX-SDWRK-5S
Drawer sizes included:
(2)6", (2)7.5", 12"

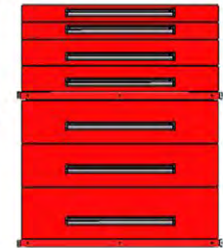

CNX-SDWRK-6S
Drawer sizes included:
(2)3", (2)4.5", (2)7.5", 9"

Deployable Kits and Accessories

Part No.	Description
CNX-BKDK	Upper bracing deployable kit
CNX-BKS-20DK	Deployable kit - Base Shelving Unit
CNX-BKSBR-20DK	Deployable kit - Base Shelving/Bulk Rack Unit
CNX-BKSWC-20DK	Deployable kit - Base Shelving/Work Center Unit
CNX-BKSWCBR-20DK	Deployable kit - Base Shelving/Work Center/Bulk Rack Unit
CNX-SDWRDK	Deployable kit - Shelving Drawer Kits
CNX-WCDWRDK	Deployable kit - Work Center Drawer Kits

Shelving Door Kits

Part No.	Description
CNX-DK-3684	Shelving Door Kit - 84"H x 36"W
CNX-DK-3642	Shelving Door Kit - 42"H x 36"W

A standard color chart is available on page 150.

SATS Insert Storage System

Years of working with Army Tool and Parts Room Managers has led to development of EQUIPTO's SATS Insert Storage System. Our system incorporates all the advantages of the SATS now in a user-friendly housing system that all shop personnel will appreciate.

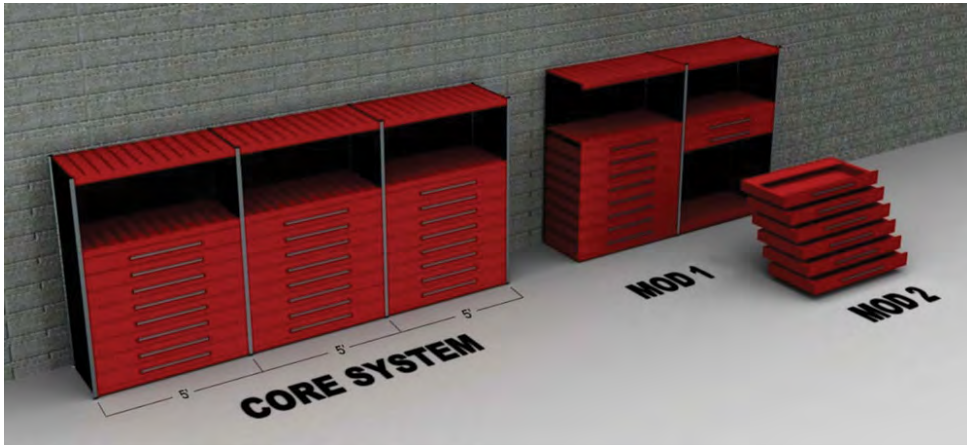

Name	Part No.
SATS CORE	1007D350-SC
MOD 1	1007D250-SM1
MOD 2	1007-SM2

Completely modular — procure for only Core Set or Full Set with Mods 1 & 2 (individually or as they are added to shop books)



More manageable — two inserts per drawer



Military grade drawers — 400 lb. capacity



Seamless integration with Tool and/or Parts Room



Weapons Cabinets

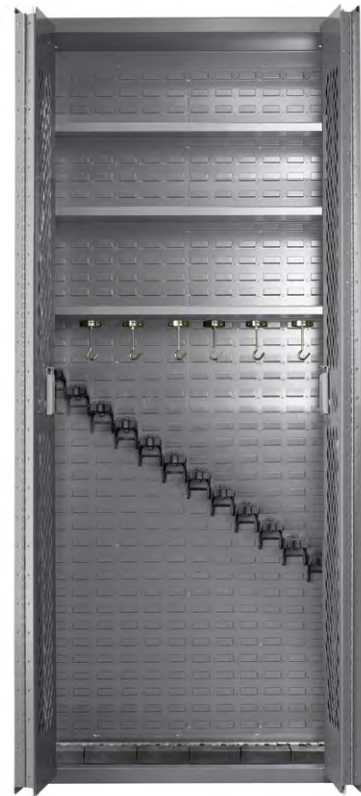

Weapons Cabinet

SPECIFICATIONS:

- 84"H x 36"W x 15"D; weighs 465 lbs
- 14-gauge all-welded steel construction
- Patented saddle system for 24 rifles
- 12 large bins with removable dividers
- Low profile handles
- Louvered back panel for full adjustability
- Bi-fold doors with 9-point locking system
- Grey textured powder coat finish

Fast Box – Large or Dual Weapons

SPECIFICATIONS:

- 47.25"W x 6.5"H x 13"D; weighs 47 lbs
- 14-gauge all-welded steel construction
- Electronic push-button lock with key override
- Black textured powder coat finish
- Three point locking system
- Full-length piano hinge door
- Louvered back panel



Combined Weapons/Crew Cabinet

SPECIFICATIONS:

- 84"H x 36"W x 15"D; weighs 465 lbs
- 14-gauge all-welded steel construction
- Low profile handles
- Louvered back panel
- Bi-fold doors with 9-point locking system (accepts standard padlock)
- Patented saddle system for 4 crew-served weapons and 12 rifles
- Three adjustable shelves
- Textured grey powder coat finish

Fast Box – Single Weapon

SPECIFICATIONS:

- 40"W x 6.5"H x 13"D; weighs 42 lbs
- 14-gauge all-welded steel construction
- Secures a firearm up to 39.5" long
- Electronic push-button lock with key override
- Two adjustable lie down straps with clip
- Black textured powder coat finish
- Three point locking system
- Full-length piano hinge door
- Neoprene padding

Weapons Storage Cabinets

Name	Part No.	Height	Width	Depth	Weight
Weapons Cabinet	WS-2424	84"	36"	15"	465 lbs
Combined Weapons/Crew Cabinet	WS-Crew	84"	36"	15"	465 lbs
Fast Box – Single Weapon	WS-Harrier	6.5"	47.5"	13"	42 lbs
Fast Box – Large or Dual Weapons	WS-Falcon	6.5"	47.5"	13"	47 lbs

Weapons Storage Systems



Pistol Peg

High density keeper with coated pegs store eleven 9mm pistols each.



Gun Stock Base

Interlocks to properly support two butt stocks within a tiered channel.

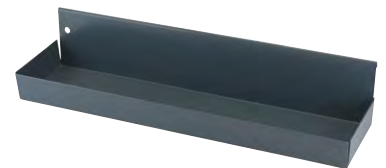

Storage Tray

Heavy duty tray designed to utilize valuable real estate behind weapons.



Upper Weapon Saddle

Patented upper single saddle adjusts to properly support any firearm at the barrel, rail or magwell.



Single Gun Stock Shelf

Works with upper saddle to secure a single long gun for cascading storage. Allows overlap of longer guns for high density storage.



Magnetic Hook

35 lb. holding capacity. Store barrels, bags and gear.



Small/Medium/Large Bins

Adjust throughout rack with removable divider.

Accessories

Name	Part No.	Width	Height	Depth
Pistol Peg	WS-PistolPeg	17"	6"	6"
Upper Weapon Saddle	WS-Saddle	17"	4.5"	2.5"
Gun Stock Base	WS-StockBase	2"	–	7"
Single Gun Stock Shelf	WS-StockShelf	6"	–	10"
Bins (Yellow Plastic)				
Small	WS-SmallBin	4"	3"	5"
Medium	WS-MediumBin	4"	3"	7"
Large	WS-LargeBin	6"	5"	11"
Storage Tray	WS-Tray	17"	4"	4"
Shelf for Cabinets (900 lb. capacity)	WS-Shelf	17"	4"	–
Magnetic Hook (35 lb. capacity)	WS-Hook	–	–	4.5"

Equipto Standard Color Chart

Textured paint is the standard on all Equipto products. Most products are available in the following colors at no additional cost. Contact Equipto Inside Sales for specific product applications.



Textured Putty



Textured Dove Gray



Textured Black



Textured Bright Yellow



Textured Cherry Red



Textured Regal Blue



Mirror Silver
(Wire Shelving Only)



Smooth Office Gray



Smooth
Reflective White



Textured Evergreen

Equipto offers a variety of additional colors, ESD paint, and custom match colors for an additional cost. Contact Equipto Inside Sales for more information.

Detailed Index

Detailed Index					
Category	Page No.	Category	Page No.	Category	Page No.
Accessories Closed Leg & Pedestal Workcenter..... 109-110 Iron-I Workcenter Accessories..... 118-119 Modular Drawer Cabinets 62-64 V-Grip™ Shelving 10-17 Adjustable Height Iron-I Workcenters 111 Aerials Workbenches 118, 123 Angle Cutter 93 Armadillo Cabinets Heavy-Duty Cabinets 130 Bin Cabinets..... 131 Janitorial Cabinets 132-133 Tool Crib Cabinets 133 Back Panels - V-Grip™ Shelving 11 End Panels - V-Grip™ Shelving 11 Bar Rack..... 32-33 Bench Cabinets 134-135 Bin Fronts Iron-Grip Shelving..... 30 V-Grip™ Shelving 13 Bin Units - V-Grip™ Shelving 8 Book Shelf Cabinet..... 127 Boltless Storage Rack..... 31 Bulk Rack 18-23 Cabinet Locks/Keys-Modular Cabinets 63 Cabinets Armadillo Cabinets..... 130-133 Bench Cabinets..... 134-135 Flammable Liquid Storage Cabinets..... 126 Mobile Computer Cabinets 129 Quick View Cabinets..... 128 Storage Cabinets 127 Carts Tool Carts 139 Wire Carts..... 135 V-Grip™ Shelving Carts 9 Casters Closed Leg Workcenters 111 Open Leg Workcenters..... 117 Teardown Bench..... 116 V-Grip™ Shelving 15 Catwalks and Walkways..... 97	Closed Leg Workcenters Accessories..... 111 Preconfigured Units 110 Clubstor Golf Storage..... 82-85 CONNEX Modules 141-142 Crossover Bridges..... 97 Divider Kits 221/2" W Modular Drawer Divider Kits 45 30" W Modular Drawer Divider Kits 50 367/8" W Modular Drawer Divider Kits 53 45" W Modular Drawer Divider Kits 57 60" W Modular Drawer Divider Kits 61 V-Grip™ Shelving 13-14 Dividers Iron-Grip Shelving 30 Modular Drawer Cabinets 64 V-Grip™ Shelving 13-14 Doors for Shelving Iron-Grip Shelving 30 V-Grip™ Shelving 15 Drawer Inserts - Modular Drawer Cabinets..... 63 Drawers in Shelving Iron-Grip Shelving 29 V-Grip™ Shelving 7 Drop Gates..... 42 Electrical Power Center Modular Drawer Cabinets 64 Workcenters..... 119 End Braces Plates - V-Grip™ Shelving 12 EquiptoBay Workcenters..... 102-103 Equiptoflex Workcenters 363 Series..... 121 364 Series..... 121 365 Series..... 121 366 Series..... 121 367 Series..... 121 384 Series..... 122 385 Series..... 122 386 Series..... 122 387 Series..... 122 388 Series..... 122 389 Series..... 122	Accessories..... 123 Extension Posts & Stacking Brackets 92 Finishing End Panels - V-Grip™ Shelving 11 Flammable Liquid Storage Cabinets 126 Flow Rack..... 21 Hanger Bar Parts..... 16 Hardwood Tops (various products)..... 62, 108-109 Heavy Duty Bar Rack..... 33 IBC Stairways..... 96 Iron-Grip Shelving 27-30 Kickplates..... 92 Label Holders Modular Drawer Cabinet Partitions..... 64 V-Grip™ Shelving 14 Landings (platform) 89 Lateral Mobile Aisle..... 80 Leveler Kit for Modular Cabinet..... 64 Mobile Aisle System Accessories..... 79 Carriages 78 Decking 78 Fixed Drive Panel 79 Manual Drive Panel 79 Mechanical Assist Drive Panel 78 Mobile Computer Cabinet..... 129 Mobile Tool Control Cabinets (FOD)..... 66 Modular Drawer Cabinets 221/2" W Preconfigured Units..... 42-44 221/2" W Modular Drawer Divider Kits 45 221/2" W Modular Drawers..... 45 221/2" W Modular Drawer Housing 44 30" W Preconfigured Units..... 46-48 30" W Modular Drawer Housing 48 30" W Modular Drawers..... 49-50 30" W Modular Drawer Divider Kits 50 367/8" W Preconfigured Units..... 51 367/8" W Modular Drawer Housing 52 367/8" W Modular Drawers..... 52-53 367/8" W Modular Drawer Divider Kits 53 45" W Preconfigured Units..... 54-55 45" W Modular Drawer Housing 55 45" W Modular Drawers..... 56-57			

45" W Modular Drawer Divider Kits	57	Perforated Open Grating	93	Miscellaneous Parts	16
60" W Preconfigured Units	58-59	Platforms	87, 89	Modular Drawers Divider Kits	13-14
60" W Modular Drawer Housing	59	Railing	92	Modular Drawers for Shelving	13
60" W Modular Drawers	60-61	Ship's Stairs	97	Open Shelving Ends	11
60" W Modular Drawer Divider Kits	61	Stair Tread Solid Panels	93	Open Solid Shelving	4
Accessories	62-64	Stairways	94-96	Partitions & Individual Dividers	13-14
Anchor Bolt	64	Pull Out Reference Shelves	13	Perimeter Bases	15
Cabinet Locks & Keys	63	Quarter Trays	63	Plastic Containers	15
Dividers (Individual)	64	Quick View Cabinets	128	Pull Out Reference Shelves	13
Drawer Inserts	63	Reel Rack	34	Rack Ends	22
Electrical Power Center	64	SATS Storage System	143	Reinforcements	10
Hardwood Tops	62	Seismic Accessories		Seismic Accessories	16
Hinged Locking Bars	63	Iron Grip	30	Shelving for Lateral Mobile Aisles	6
Leveler Kit	64	V-Grip™ Shelving	16	Sliding Dividers	14
Mobile Tool Control Cabinets	66	Shelf Drawers & Cabinets	69-75	Solid Rack Decking Panels	19-20
Mobile Unit Kit	63	Shelves (extra)		Solid Back Panels	11
Partitions (Individual)	64	Iron-Grip Shelving	30	Solid End Panels	11
Partitions & Individual Sets	64	V-Grip™ Shelving	10	Solid Shelves Heavy Duty 18ga	10
Plastic Bins	63	Wire Shelving	37	Solid Shelves Heavy Duty Reinforced	10
Shelving Cabinets	65	Zip-In Shelving	26	Spill Containment System	6
Sliding Doors w/Locks	65	Sliding Dividers		Tie Bars	22
Sloping Desk Top	63	V-Grip™ Shelving	14	Tire Rack	24
Stationary & Roll Out Shelves	62	Zip-In Shelving	26	Top/Bottom Caps	14
Swinging Doors (Flush Mount)	62	Sliding Doors with Locks	65	Upright Posts	10
Swinging Doors for 44"H & 59"H Cabinets	62	Solid Back Panels - V-Grip™ Shelving	11	Wire Back & End Grids	12
Motorized Pallet Rack	81	Solid End Panels - V-Grip™ Shelving	11	Wire Dividers	15
NC Tool Holders	68, 139	Solid Laminated Tops	62, 108-109	Wire Rack	5, 37-39
OmniVerse Workcenters		Specialty Racks	35	Wire Rack Deck Grids	10
Accessories	100-101	Stairways	94-96	Wire Shelves (Truss Included)	37
Build-Your-Own	100	Storage Cabinets	127	Wire Shelving	5, 37-39
Preconfigured	99	Swinging Doors - Modular Drawer Cabinets	62	Wire Shelves Grids	10
Open Leg Workcenters		Teardown Bench	116	Wire Shelves Trusses	10
2200 Series	114	Tech Bench	104-107	Workcenters	17
2300 Series	114	Tie Bars	22	V-Grip™ Wire Rack	5
2400 Series	115	Tire Rack	24	Walkways	97
2500 Series	115	Tool Cabinet	67	Wall Mount Open Leg Bench	116
Accessories	118-119	Top/Bottom Caps	22	Weapons Mobile Aisle System	81
Mobile Kit	117	Upright Posts		Weapons Storage	144-145
Open Safety Grating	93	Iron-Grip Shelving	30	Wire Rack Carts	35
OSHA Stairways	95-96	V-Grip™ Shelving	10	Wire Spool Rack	35
Partitions		V-Grip™ Bulk Rack	18-19	Workcenters	
Modular Drawer Cabinets	64	V-Grip™ Shelving	2-24	Accessories	118
V-Grip™ Shelving	13-14	Back Sway Braces	12	Adjustable Height Iron-I Workcenters	112
Pedestal Workcenters		Bin Fronts	13	Closed Leg Workcenters	110
Accessories	118-119	Bin Units	8	Equiptoflex Workcenters	121-122
Preconfigured Units	109	Bulk Rack	18-23	Equiptoflex Accessories	123
Perforated Open Grating	93	Bulk Rack Solid Decking	19-20	Modular Drawer Cabinet Workcenters	108
Perimeter Bases	15	Bulk Rack Wire Decking	19-20	OmniVerse Workcenters	99-100
Pick Rack	75	Carts	9	Open Leg Workcenters	114-115
Plastic Containers	15	Closed Shelving Ends	11	Zip-In Shelving	25-26
Platforms		Closed Solid Shelving	4		
Angle Cutter	93	Components	10-17		
Catwalks & Walkways	88	Doors for Shelving	15		
Crossover Bridges	97	Drawers in Shelving	7		
Drop Gates	92	Economy Wire Rack	37-39		
Extension Posts & Stacking Brackets	92	End Braces Plates	12		
Flooring Options	91	Finishing End Panels	11		
IBC Stairways	96	Front Bases	13		
Kickplates	92	Full Height Shelf Dividers	14		
Landings	89	Hanger Bar Parts	16		
OSHA Stairways	95-96	Label Holders	14		

EQUIPTO[®]

ONE DECISION • INFINITE SOLUTIONS

2019 Product Catalog



Consolidated Storage Companies, Inc.

 **Material Handling USA**
800-326-4403
<https://www.mh-usa.com/>
Sales@MaterialHandling-USA.com

 **Material Handling USA**
Call Now for a Free Quote or Site Visit!
222 S. Main St. 5th Floor
Salt Lake City, UT 84101
800-326-4403
<https://www.mh-usa.com/>
Material Handling USA

SUPERSTORE

MH-USA