

AURORA STORAGE

MJ LIBRARY PLANNING GUIDE



 **Material Handling USA**
800-326-4403
<https://www.mh-usa.com/>

TABLE OF CONTENTS



MJ Library Shelving	3 - 6
<hr/>	
System 30®	7 - 40
<hr/>	
Welded Frame 1000 Series	41 - 69
<hr/>	
Movable Concealed Caster Units	70
<hr/>	
Curved Shelving	71 - 72
<hr/>	
Media Display Shelving	73 - 76
<hr/>	
Escalook™	77 - 83



MJ LIBRARY SHELVING



Top Shelf Solutions for Today's Libraries™

MJ LIBRARY SHELVING BY

 **Material Handling USA**
800-326-4403
<https://www.mh-usa.com/>

MJ LIBRARY SHELVING



For over twenty years the MJ Library name has been synonymous with high quality shelving and storage solutions for all types of libraries including K-12 Schools and Universities, Corporate, Medical, Public, and Private Institutions.

Hundreds of Libraries in North America have chosen MJ Library Shelving to house their collections:

- Argonne National Laboratory
- Augustana College - Denkmann Hall
- Beverly Public Library
- Boston University School of Management
- Brigham and Women's Hospital Medical Library
- Captiva Memorial Library
- DePaul University Library
- Duke University
- Dunbar Library
- Eglin Air Force Base Library
- Glen Ellyn Public Library
- Harvard Law School Langdell Hall
- J. Paul Getty Center
- Kaiser Permanente Fontana
- Louisiana State University Medical Center
- Stanford University - J. Hugh Jackson Library
- University of Toronto - Robarts Library
- University of South Alabama
- V.A. Medical Center
- U.C.L.A. Law Library



The MJ Advantage

Always a great value with minimal lead times, MJ Library Shelving is quality shelving designed with flexibility to meet the demands of your unique library.

We Offer

- A broad line of accessories
- Specialty items such as concealed caster units
- Custom color matches
- Special heights and widths on certain models
- A national sales organization at your service
- Planning and design support

MJ Curved Library Shelving

Just one of the amazing products we can manufacture for your library.

MJ System 30 Shelving

System 30 is a versatile line of starter/adder library shelving with a contemporary appearance. A single slot design allows for increased storage and its narrow footprint can create wider aisles for ADA compliance. MJ System 30 can even be increased in height over time.

- No overhead bracing or floor fastening required
- 1" Shelf profile prevents deflection over time
- Hundreds of accessories to store various collections

Options

- Starter and Adder
- Single and Double Face Units
- Single and Double Face Divider Units
- Steel End Panels and Closed Back Options
- Mix and Match Accessories
- Width: 36" (24" and 30" also available)
- Heights: 42", 60", 66", 72", 78", 84", 90"



MJ 1000 Shelving

This welded frame shelving lowers installation costs and eliminates the need for sway braces which can be unsightly. Each unit is stand alone and allows clear filing from one side to the other for oversized volumes.

- One piece base shelf and base brackets
- Canopy top accepts wire book supports
- Hundreds of accessories to store various collections

Options

- Stand alone independent units
- Single and Double Face Units
- Single and Double Face Divider Units
- Seismic Welded Frames
- Steel End Panels and Closed Back Options
- Mix and Match Accessories
- Width: 36" (24" and 30" also available)
- Heights: 42", 66", 78", 84", 90"

FINISHES AND OPTIONS

Choose from 15 beautiful powder coat finishes or custom match to your unique décor.

Accessories

MJ Library Shelving from Aurora features accessory solutions for every library need. Choose from:

- Concealed Caster Units
- Sliding Door Cabinets
- Hinged and Fixed Periodical Shelves
- Multimedia Display Shelves
- Tip-Up Periodical Cabinets
- Canopy Tops, Steel End Panels, Closed Backs
- Hang Up Bags Racks
- Caster Units
- Hinged and Fixed Periodical Units
- Single and Double Tier Browser Boxes for AV Media
- Display Systems
- Newspaper Rack
- Zig-Zag Display Shelf
- Slide out Reference Shelves
- Column Extenders



Caster Units



Concealed Caster Units



Browser Box



Periodical Display



Zig Zag Display Shelf



Media Display

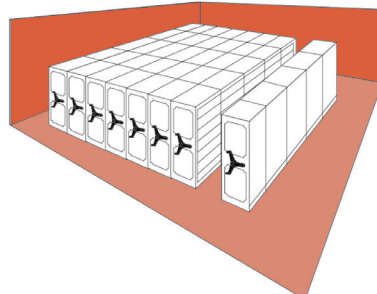
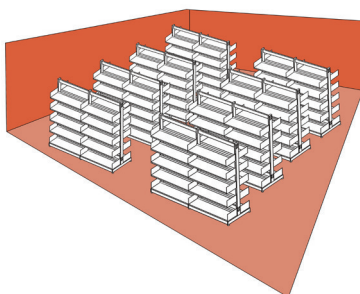

Convert Freestanding MJ Library Shelving to mobile ready to save 50% of floor space or store



MJ LIBRARY SHELVING BY

AURORA

A SOLUTION FOR EVERY STORY

Material Handling USA

Call Now for a Free Quote or Site Visit!

222 S. Main St. 5th Floor
Salt Lake City, UT 84101
800-326-4403
<https://www.mh-usa.com/>

Material Handling USA

SUPERSTORE

MH-USA

SYSTEM 30™



**Call Now for a Free
Quote or Site Visit!**

222 S. Main St. 5th Floor
Salt Lake City, UT 84101
800-326-4403
<https://www.mh-usa.com/>

SUPERSTORE

MH-USA

Material Handling USA



MJ Library Shelving by Aurora was founded in 1988 with the goal of becoming the best manufacturer of steel cantilever library shelving on the market. The flagship line, System 30™, developed decades ago, is renowned for its popularity in public, education, legal, and corporate library installations across the US and Canada.

Its versatile design features consistent high quality material and superior fit and finish making it the storage solution of choice for today's libraries.

A full line of accessories such as shelves, work surfaces, and media display units for CDs, DVDs, periodicals, and new books make this a very adaptable system. Specialty items such as carts, concealed caster carts, and curved shelving round out the System 30 Shelving line.

Call Aurora Storage Products today for questions about System 30 Shelving or to help with your shelving and storage needs.

ADVANTAGES OF SYSTEM 30™ vs CONVENTIONAL SHELVING



CHANGING THE STORY:

A library is about bringing people together – but our easily reconfigurable solutions allow you to keep people a safe distance apart. Shelves on casters can be arranged any way you need to easily accommodate social distancing guidelines.

1. More filing space per shelf.
2. Modern / contemporary look of our end brackets and columns eliminates the need for end panels.
3. More usable floor space as the base depth can be the same size as the shelves above.
4. Units can be converted from closed to open base without purchasing additional parts or dismantling the shelving.
5. Accessories and components to meet the needs of today's library can be easily mixed and matched on any section.
6. Our state-of-the-art powder-coat paint system provides you with the most durable paint finish in the industry.
7. Special colors can be matched to please even the most discriminating eye.
8. On time delivery. Most deliveries can be made in eight to ten weeks after receipt of order.
9. All this and you still get the quality that has become synonymous with MJ Library Shelving by Aurora.

We have a nationwide sales organization which is fully trained to assist you with your library planning.

Please contact MJ Library Shelving by Aurora:
1-800-277-1699 for the name and phone number of your local representative.

BASIC COMPONENTS

Typical Starter Unit

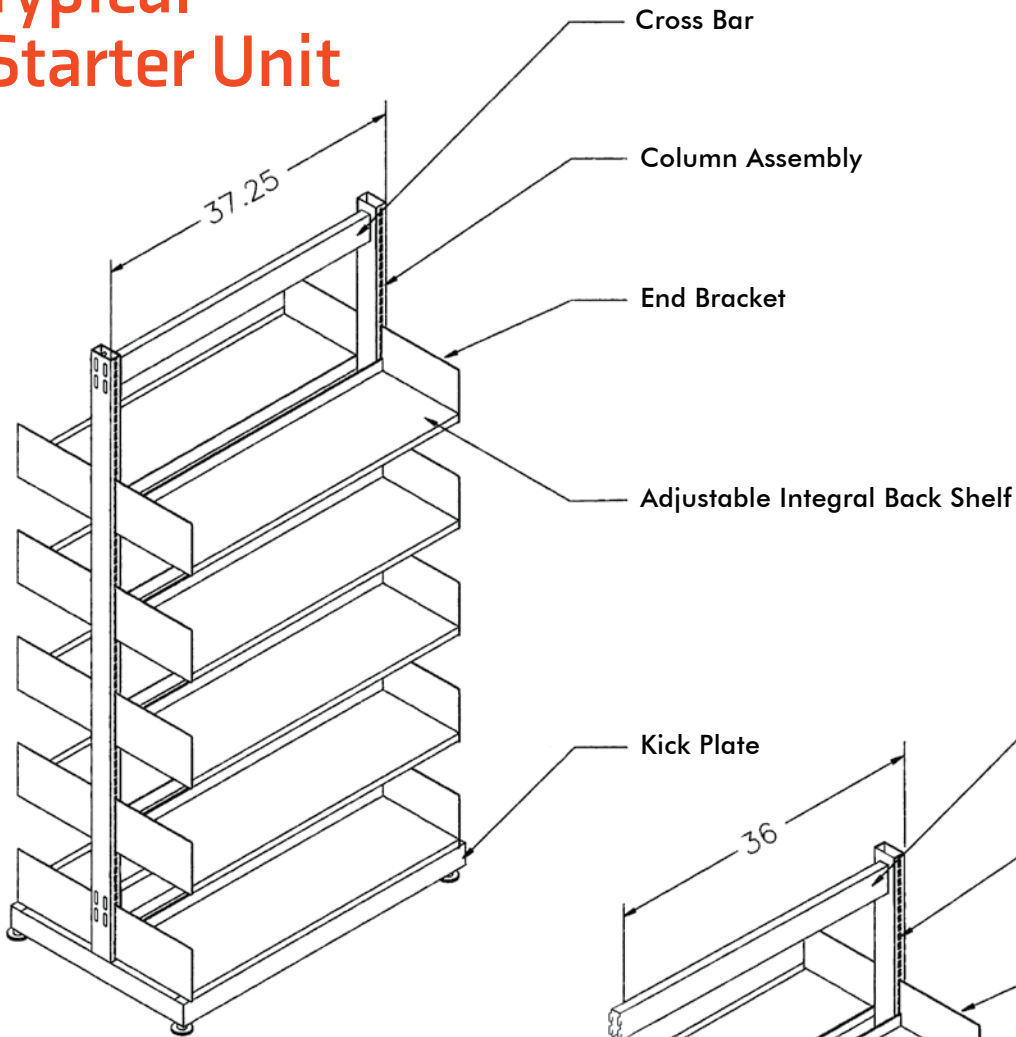

Typical Adder Unit

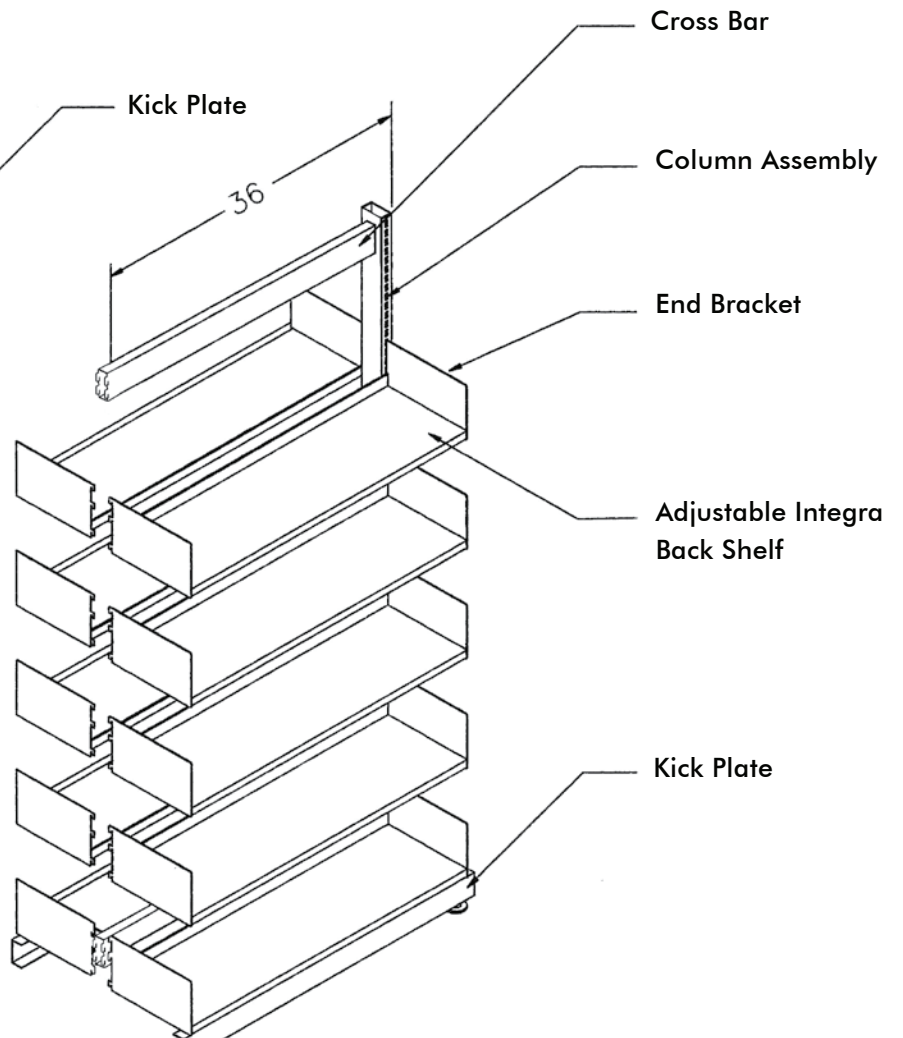

BASIC COMPONENTS

Typical Starter Unit

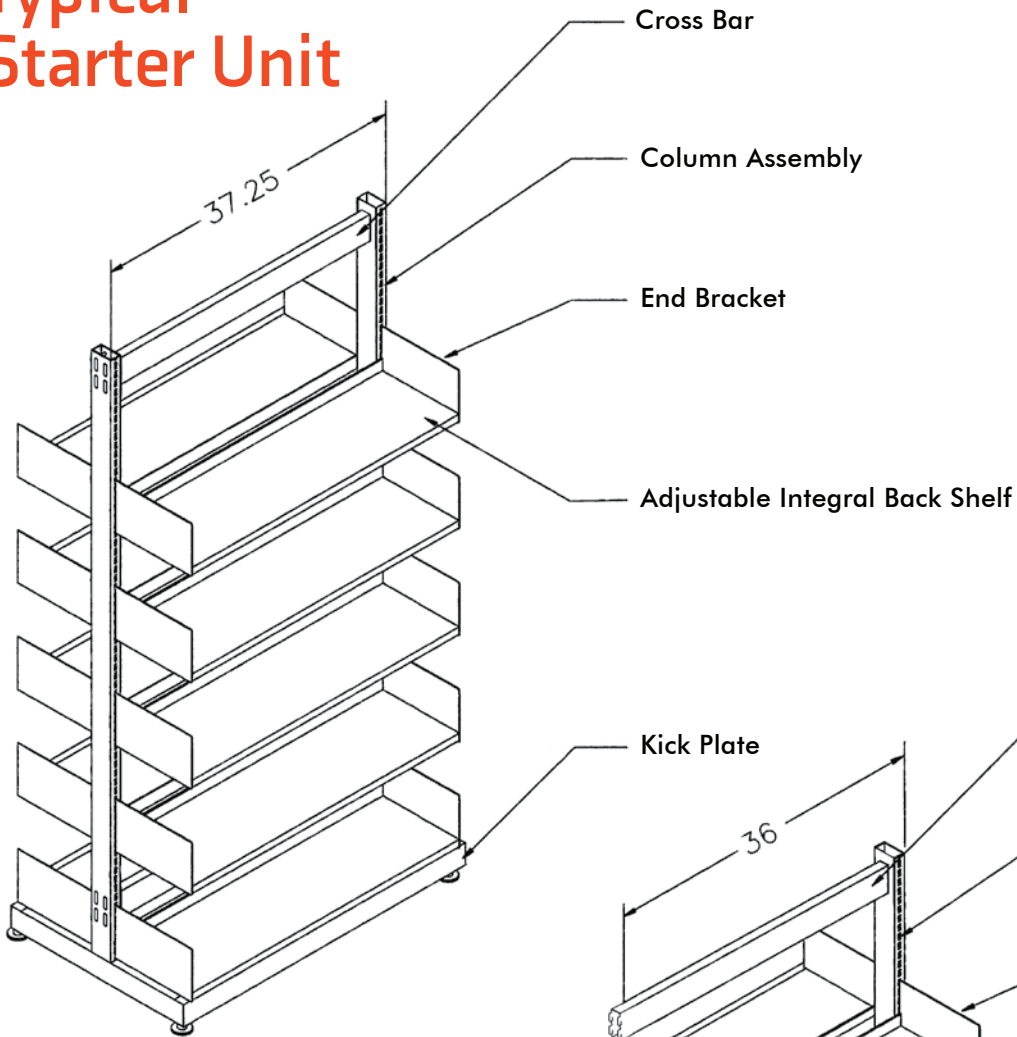

Typical Adder Unit

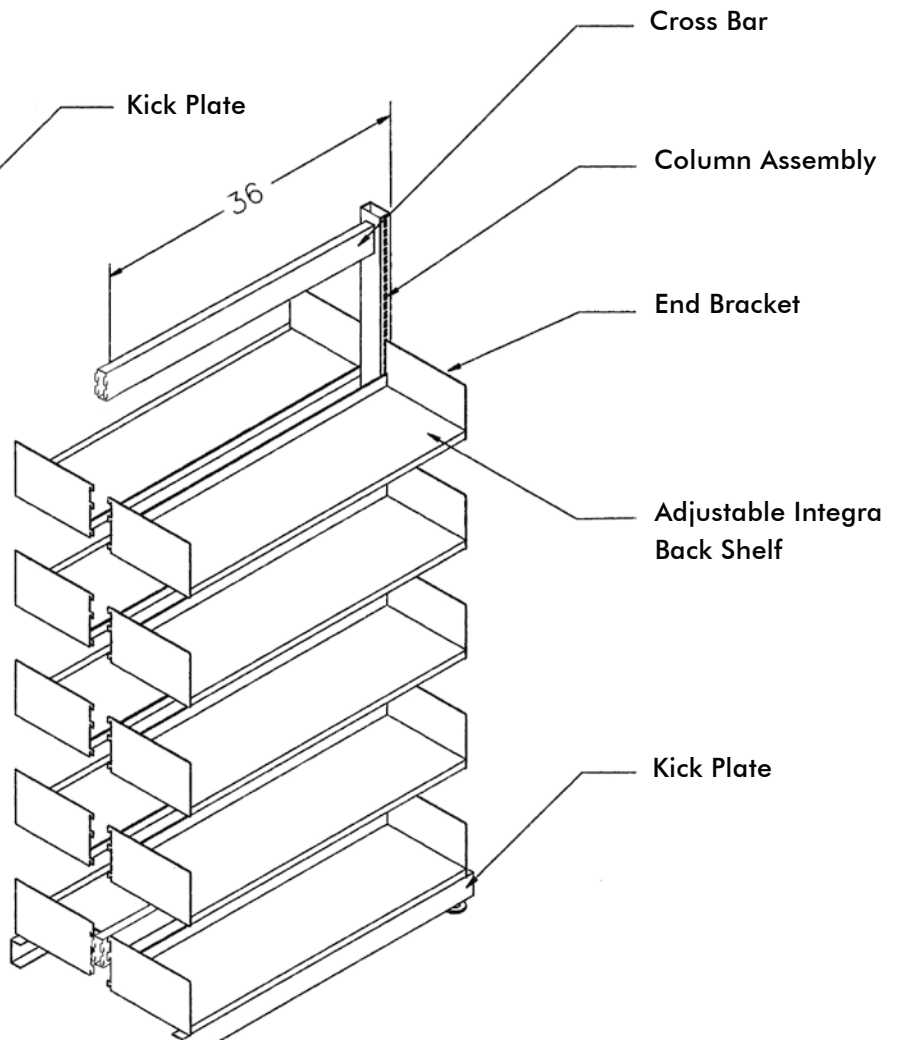

SYSTEM 30™

Starter Unit

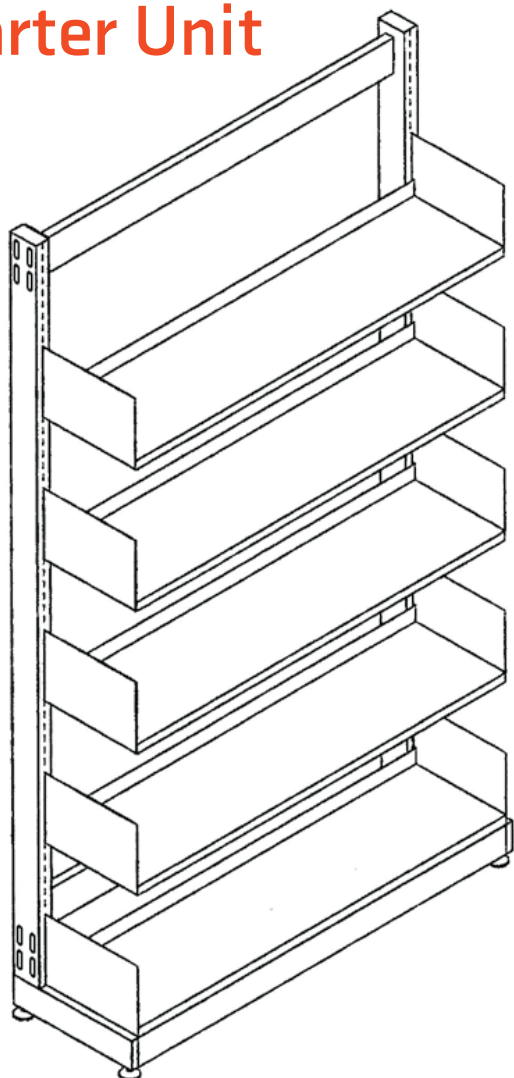

Integral Back Shelves

Single Face Units

3 Adjustable Shelves – 42" High

CATALOG NO.	SHELF	WEIGHT
S3-36090942-S	9	51
S3-36090942-A	9	43½
S3-36101042-S	10	53½
S3-36101042-A	10	45½
S3-36111142-S	11	55
S3-36111142-A	11	47
S3-36131342-S	13	60½
S3-36131342-A	13	52
S3-36171742-S	17	69
S3-36171742-A	17	60

4 Adjustable Shelves – 60" High

CATALOG NO.	SHELF	WEIGHT
S3-36090960-S	9	65½
S3-36090960-A	9	54½
S3-36101060-S	10	68½
S3-36101060-A	10	57
S3-36111160-S	11	70½
S3-36111160-A	11	59
S3-36131360-S	13	77½
S3-36131360-A	13	65½
S3-36171760-S	17	88½
S3-36171760-A	17	76

5 Adjustable Shelves – 66" High

CATALOG NO.	SHELF	WEIGHT
S3-36090966-S	9	73
S3-36090966-A	9	62
S3-36101066-S	10	77½
S3-36101066-A	10	65½
S3-36111166-S	11	80
S3-36111166-A	11	68
S3-36131366-S	13	88½
S3-36131366-A	13	76
S3-36171766-S	17	102
S3-36171766-A	17	89

Starter unit includes two column assemblies, cross bars, kick plate, integral back shelves, and end brackets. Adder unit is the same as a starter except it includes only one column assembly. All shelf sizes are nominal.

Book supports must be ordered separately.

Integral Back Shelves (Continued)

5 Adjustable Shelves – 72" High

CATALOG NO.	SHELF	WEIGHT
S3-36090972-S	9	77
S3-36090972-A	9	64
S3-36101072-S	10	80½
S3-36101072-A	10	67
S3-36111172-S	11	83
S3-36111172-A	11	69½
S3-36131372-S	13	91½
S3-36131372-A	13	77½
S3-36171772-S	17	105
S3-36171772-A	17	90½

6 Adjustable Shelves – 78" High

CATALOG NO.	SHELF	WEIGHT
S3-36090978-S	9	85½
S3-36090978-A	9	72
S3-36101078-S	10	89½
S3-36101078-A	10	75½
S3-36111178-S	11	92½
S3-36111178-A	11	78½
S3-36131378-S	13	102½
S3-36131378-A	13	88
S3-36171778-S	17	118½
S3-36171778-A	17	103½

7 Adjustable Shelves – 84" High

CATALOG NO.	SHELF	WEIGHT
S3-36090984-S	9	94
S3-36090984-A	9	80
S3-36101084-S	10	98½
S3-36101084-A	10	84
S3-36111184-S	11	102
S3-36111184-A	11	87½
S3-36131384-S	13	113½
S3-36131384-A	13	98½
S3-36171784-S	17	132
S3-36171784-A	17	116½

7 Adjustable Shelves – 90" High

CATALOG NO.	SHELF	WEIGHT
S3-36090990-S	9	96
S3-36090990-A	9	81
S3-36101090-S	10	102½
S3-36101090-A	10	85
S3-36111190-S	11	104
S3-36111190-A	11	88½
S3-36131390-S	13	115½
S3-36131390-A	13	99½
S3-36171790-S	17	134
S3-36171790-A	17	117½

Adder Unit

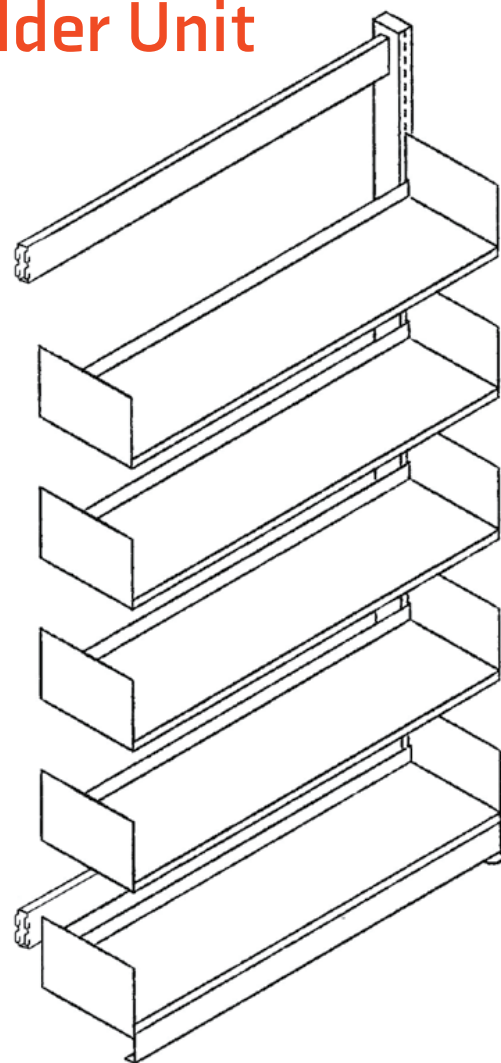

SYSTEM 30™

Starter Unit

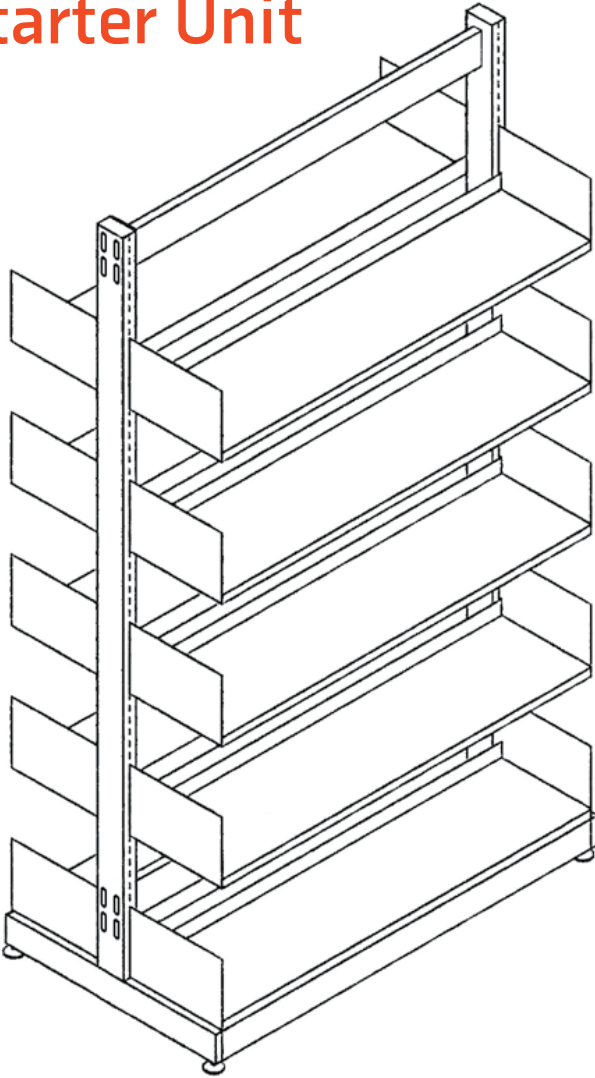

Integral Back Shelves

Double Face Units

6 Adjustable Shelves – 42" High

CATALOG NO.	SHELF	WEIGHT
S3-36091842-S	9	78
S3-36091842-A	9	69
S3-36102042-S	10	82
S3-36102042-A	10	72½
S3-36112242-S	11	86
S3-36112242-A	11	76
S3-36132642-S	13	96
S3-36132642-A	13	85½
S3-36173442-S	17	113
S3-36173442-A	17	101½

8 Adjustable Shelves – 60" High

CATALOG NO.	SHELF	WEIGHT
S3-36091860-S	9	101
S3-36091860-A	9	88
S3-36102060-S	10	106
S3-36102060-A	10	92½
S3-36112260-S	11	111
S3-36112260-A	11	97
S3-36132660-S	13	124
S3-36132660-A	13	109½
S3-36173460-S	17	146
S3-36173460-A	17	130½

10 Adjustable Shelves – 66" High

CATALOG NO.	SHELF	WEIGHT
S3-36091866-S	9	118
S3-36091866-A	9	104
S3-36102066-S	10	124
S3-36102066-A	10	109½
S3-36112266-S	11	130
S3-36112266-A	11	115
S3-36132666-S	13	146
S3-36132666-A	13	130½
S3-36173466-S	17	173
S3-36173466-A	17	156½

Starter unit includes two column assemblies, cross bars, kick plate, integral back shelves, and end brackets. Adder unit is the same as a starter except it includes only one column assembly. All shelf sizes are nominal.

Book supports must be ordered separately.

Integral Back Shelves (Continued)

10 Adjustable Shelves – 72" High

CATALOG NO.	SHELF	WEIGHT
S3-36091872-S	9	119
S3-36091872-A	9	104 ¹ / ₂
S3-36102072-S	10	125
S3-36102072-A	10	110
S3-36112272-S	11	131
S3-36112272-A	11	115 ¹ / ₂
S3-36132672-S	13	147
S3-36132672-A	13	131
S3-36173472-S	17	174
S3-36173472-A	17	157

12 Adjustable Shelves – 78" High

CATALOG NO.	SHELF	WEIGHT
S3-36091878-S	9	135
S3-36091878-A	9	120
S3-36102078-S	10	142
S3-36102078-A	10	126 ¹ / ₂
S3-36112278-S	11	149
S3-36112278-A	11	133
S3-36132678-S	13	168
S3-36132678-A	13	151 ¹ / ₂
S3-36173478-S	17	200
S3-36173478-A	17	182 ¹ / ₂

14 Adjustable Shelves – 84" High

CATALOG NO.	SHELF	WEIGHT
S3-36091884-S	9	152
S3-36091884-A	9	136
S3-36102084-S	10	160
S3-36102084-A	10	143 ¹ / ₂
S3-36112284-S	11	167
S3-36112284-A	11	150 ¹ / ₂
S3-36132684-S	13	189
S3-36132684-A	13	172
S3-36173484-S	17	227
S3-36173484-A	17	208 ¹ / ₂

14 Adjustable Shelves – 90" High

CATALOG NO.	SHELF	WEIGHT
S3-36091890-S	9	153
S3-36091890-A	9	136 ¹ / ₂
S3-36102090-S	10	161
S3-36102090-A	10	144
S3-36112290-S	11	169
S3-36112290-A	11	151 ¹ / ₂
S3-36132690-S	13	191
S3-36132690-A	13	173
S3-36173490-S	17	228
S3-36173490-A	17	209

Adder Unit

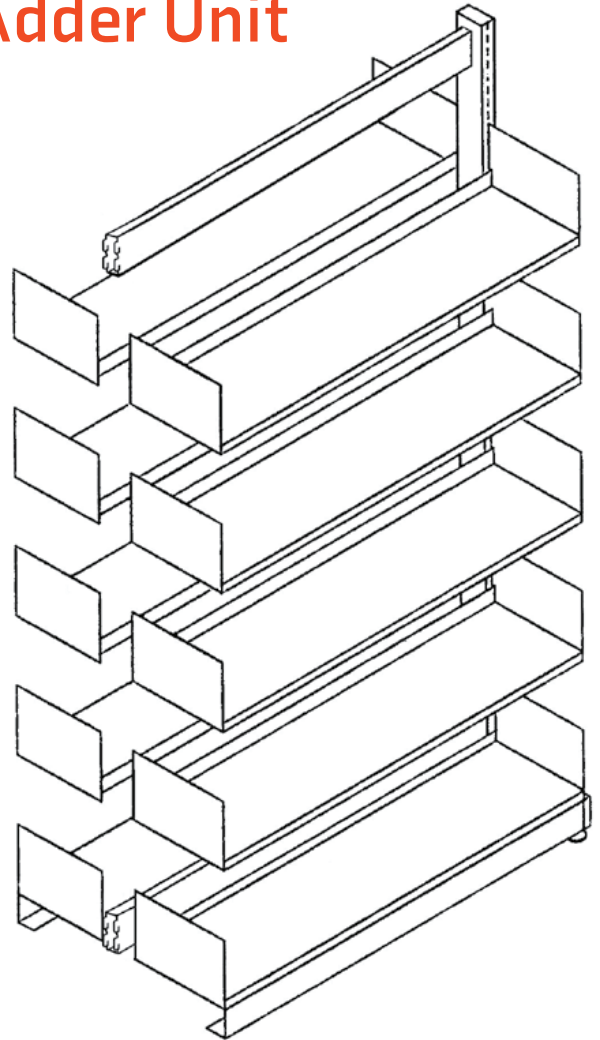

Starter Unit

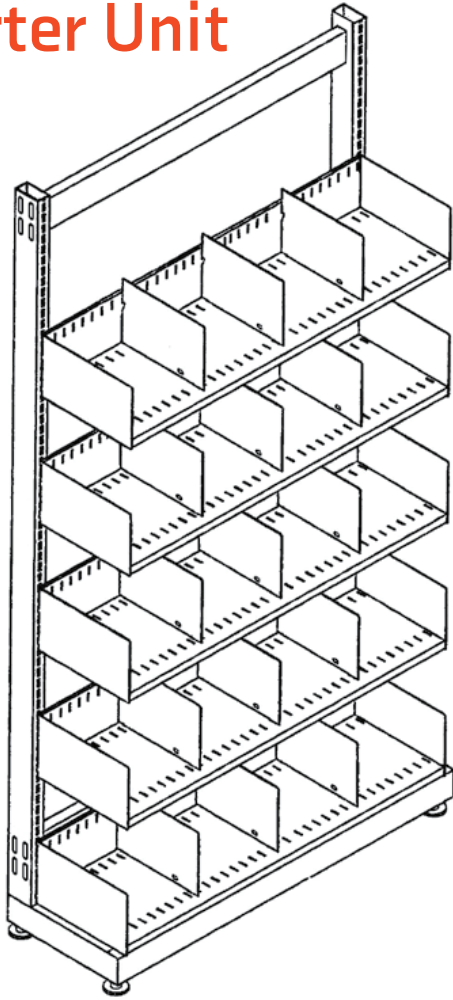

Adder Unit

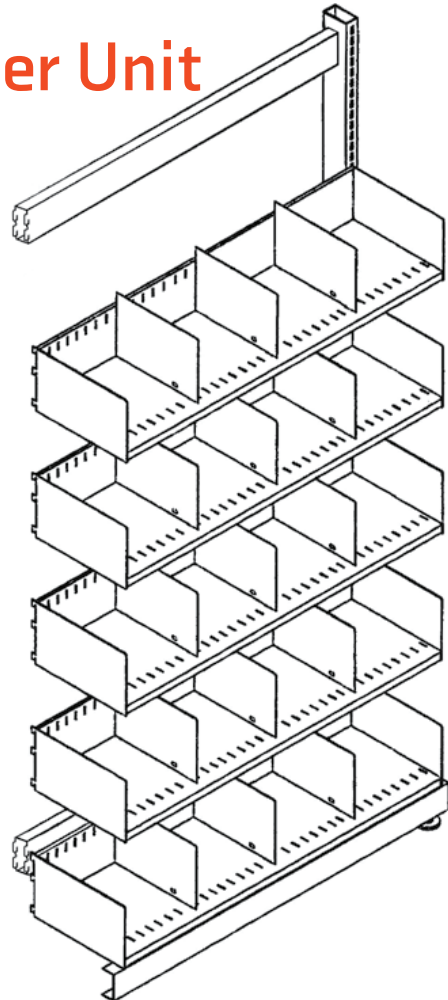

System 30®

Single Face Divider Units

3 Divider Shelves – 42" High

CATALOG NO.	SHELF	WEIGHT
S3-D36101042-S	10	81
S3-D36101042-A	10	73
S3-D36131342-S	13	91
S3-D36131342-A	13	82½

4 Divider Shelves – 60" High

CATALOG NO.	SHELF	WEIGHT
S3-D36101060-S	10	105
S3-D36101060-A	10	93½
S3-D36131360-S	13	118
S3-D36131360-A	13	106

5 Divider Shelves – 66" High

CATALOG NO.	SHELF	WEIGHT
S3-D36101066-S	10	123
S3-D36101066-A	10	111
S3-D36131366-S	13	139
S3-D36131366-A	13	126½

6 Divider Shelves – 78" High

CATALOG NO.	SHELF	WEIGHT
S3-D36101078-S	10	144
S3-D36101078-A	10	130
S3-D36131378-S	13	163
S3-D36131378-A	13	148½

7 Divider Shelves – 90" High

CATALOG NO.	SHELF	WEIGHT
S3-D36101090-S	10	164
S3-D36101090-A	10	148½
S3-D36131390-S	13	186
S3-D36131390-A	13	170

Starter unit includes two column assemblies, cross bars, kick plate, divider shelf with three dividers per shelf, and end brackets. Adder unit is the same as a starter except it includes only one column assembly. All shelf sizes are nominal.

System 30®

Double Face Divider Units

6 Divider Shelves – 42" High

CATALOG NO.	SHELF	WEIGHT
S3-D36102042-S	10	136
S3-D36102042-A	10	126½
S3-D36132642-S	13	156
S3-D36132642-A	13	145½

8 Divider Shelves – 60" High

CATALOG NO.	SHELF	WEIGHT
S3-D36102060-S	10	178
S3-D36102060-A	10	164½
S3-D36132660-S	13	204
S3-D36132660-A	13	189½

10 Divider Shelves – 66" High

CATALOG NO.	SHELF	WEIGHT
S3-D36102066-S	10	214
S3-D36102066-A	10	199½
S3-D36132666-S	13	246
S3-D36132666-A	13	230½

12 Divider Shelves – 78" High

CATALOG NO.	SHELF	WEIGHT
S3-D36102078-S	10	250
S3-D36102078-A	10	234½
S3-D36132678-S	13	288
S3-D36132678-A	13	271½

14 Divider Shelves – 90" High

CATALOG NO.	SHELF	WEIGHT
S3-D36102090-S	10	287
S3-D36102090-A	10	270
S3-D36132690-S	13	331
S3-D36132690-A	13	313

Starter unit includes two column assemblies, cross bars, kick plate, divider shelf with three dividers per shelf, and end brackets. Adder unit is the same as a starter except it includes only one column assembly. All shelf sizes are nominal.

Starter Unit

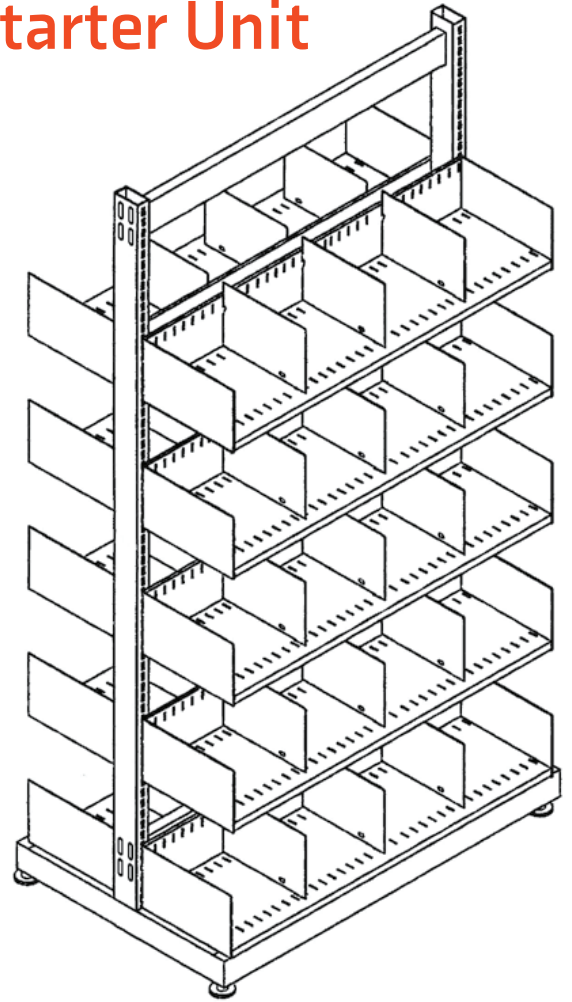

Adder Unit

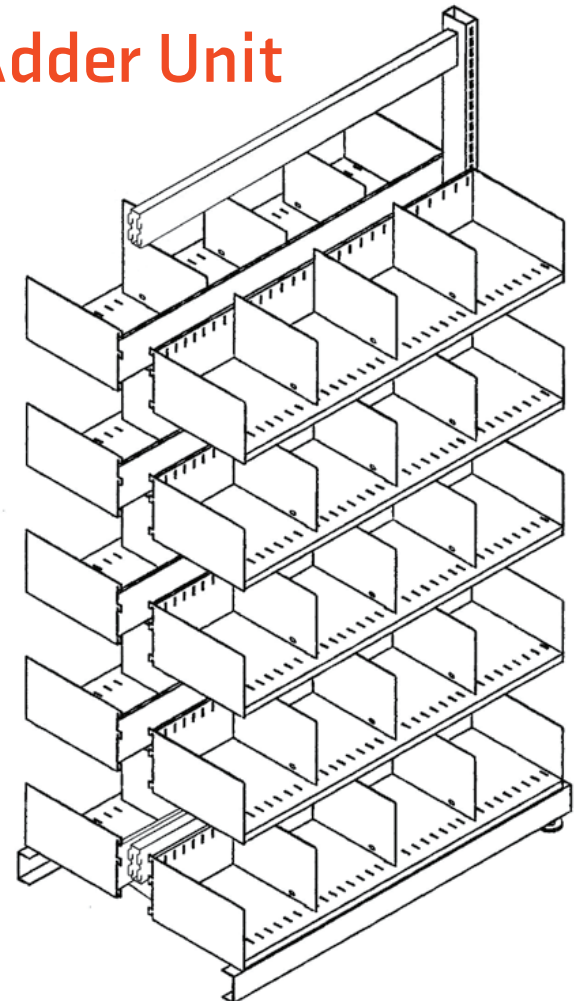

System 30®

Hinged Periodical Units

Single Face

CATALOG NO.	SHELF	WEIGHT
S3-H36141442-S	14	65
S3-H36141442-A	14	56½
S3-H36141466-S	14	107
S3-H36141466-A	14	94½
S3-H36141478-S	14	128½
S3-H36141478-A	14	114
S3-H36141490-S	14	148
S3-H36141490-A	14	132

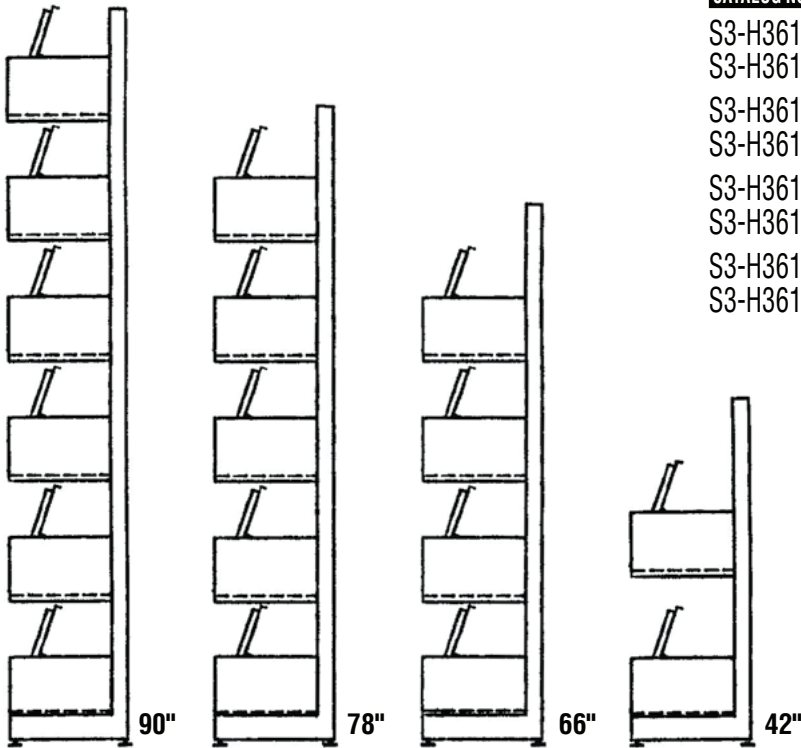

Double Face

CATALOG NO.	SHELF	WEIGHT
S3-H36142842-S	14	104
S3-H36142842-A	14	93½
S3-H36142866-S	14	182
S3-H36142866-A	14	166½
S3-H36142878-S	14	218
S3-H36142878-A	14	201½
S3-H36142890-S	14	255
S3-H36142890-A	14	237

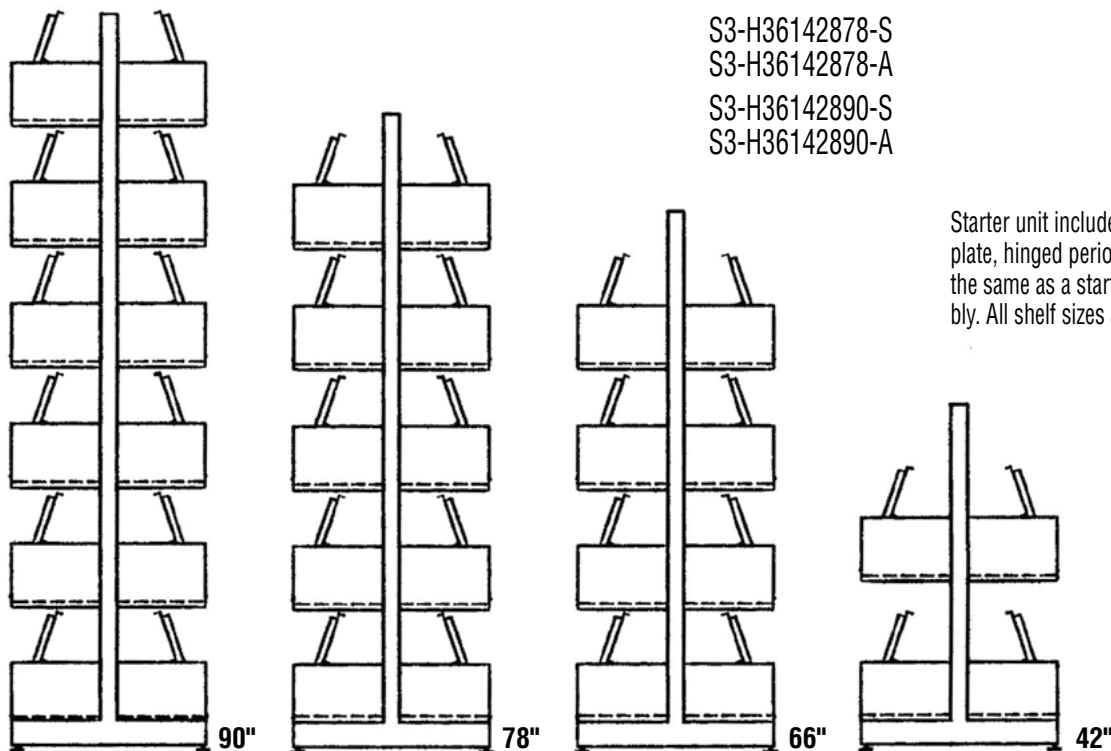

Starter unit includes two column assemblies, cross bars, kick plate, hinged periodical shelves and end brackets. Adder unit is the same as a starter except it includes only one column assembly. All shelf sizes are nominal.

System 30®

Fixed Periodical Units

Single Face

CATALOG NO.	SHELF	WEIGHT
S3-F36131342-S	13	70
S3-F36131342-A	13	61½
S3-F36131366-S	13	97½
S3-F36131366-A	13	85
S3-F36131378-S	13	121
S3-F36131378-A	13	106½
S3-F36131390-S	13	143½
S3-F36131390-A	13	127½

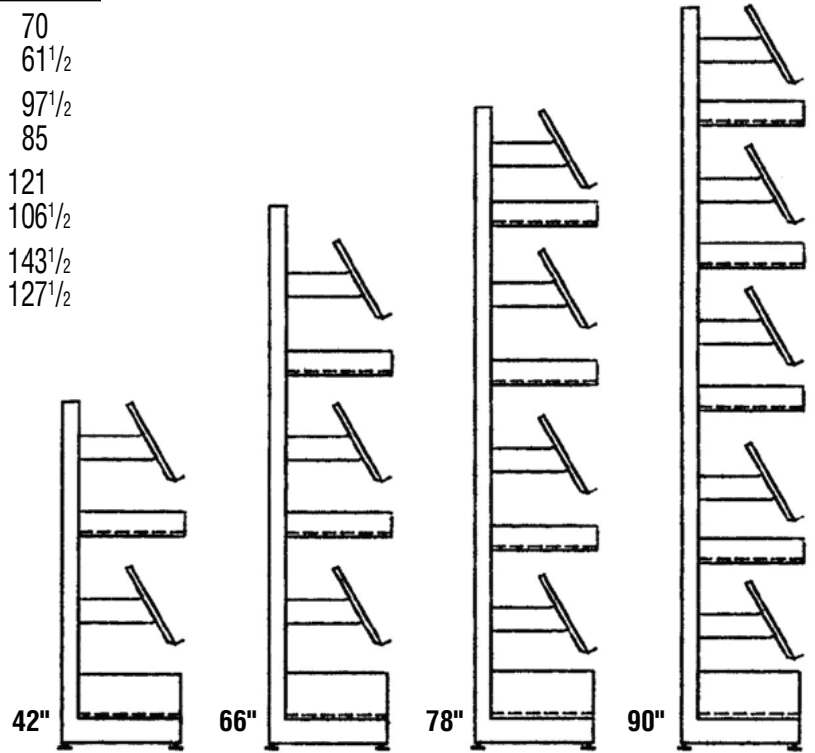

Double Face

CATALOG NO.	SHELF	WEIGHT
S3-F36132642-S	13	114
S3-F36132642-A	13	103½
S3-F36132666-S	13	163
S3-F36132666-A	13	147½
S3-F36132678-S	13	204
S3-F36132678-A	13	187½
S3-F36132690-S	13	246
S3-F36132690-A	13	228

Starter unit includes two column assemblies, cross bars, kick plate, fixed periodical shelf, storage shelf, and end brackets. Adder unit is the same as a starter except it includes only one column assembly. 30° periodical shelf is furnished unless specified otherwise. All shelf sizes are nominal.

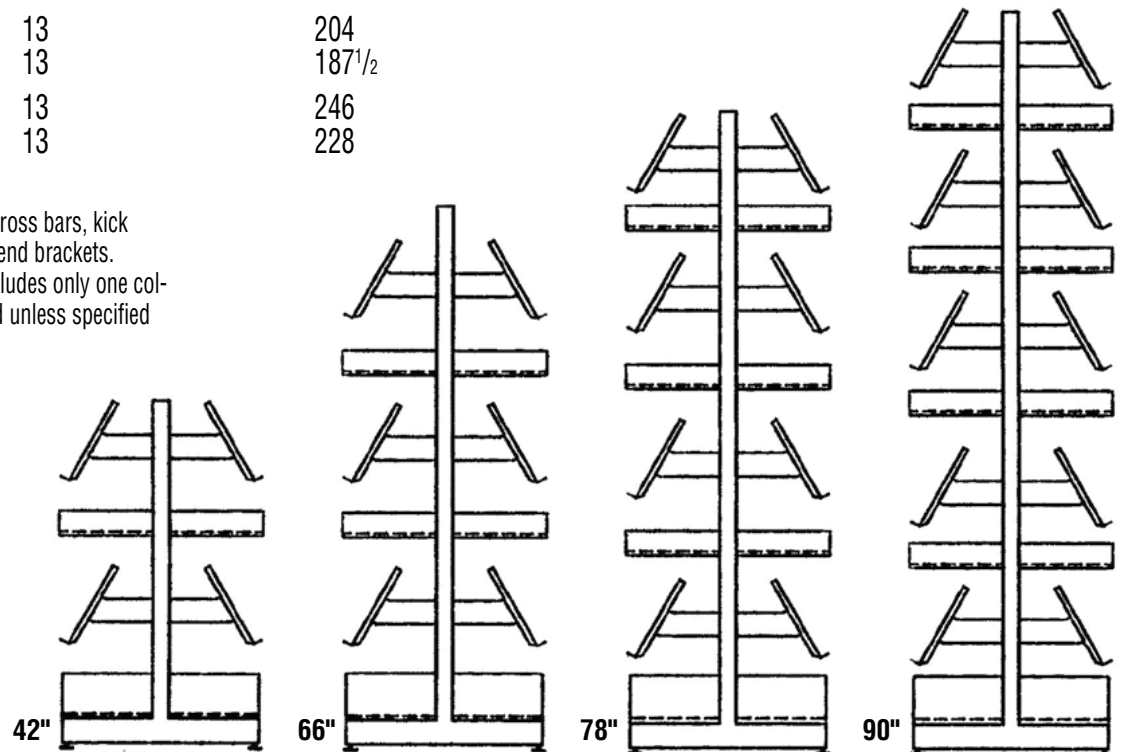

System 30®

Column Assembly

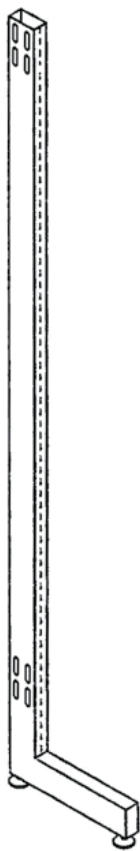

Single Faced (1¹/₄ x 2¹/₂–14 gauge)

CATALOG NO.	NOMINAL SHELF DEPTH	OVERALL UPRIGHT DEPTH	NOMINAL HEIGHT	WEIGHT
S3-SCA0942	9	10 ¹ / ₂	42	7 ¹ / ₂
S3-SCA1042	10	11 ¹ / ₂	42	8
S3-SCA1142	11	12 ¹ / ₂	42	8
S3-SCA1342	13	14 ¹ / ₂	42	8 ¹ / ₂
S3-SCA1442	14	15 ¹ / ₂	42	8 ¹ / ₂
S3-SCA1742	17	18 ¹ / ₂	42	9
S3-SCA0960	9	10 ¹ / ₂	60	11
S3-SCA1060	10	11 ¹ / ₂	60	11 ¹ / ₂
S3-SCA1160	11	12 ¹ / ₂	60	11 ¹ / ₂
S3-SCA1360	13	14 ¹ / ₂	60	12
S3-SCA1460	14	15 ¹ / ₂	60	12
S3-SCA1760	17	18 ¹ / ₂	60	12 ¹ / ₂
S3-SCA0966	9	10 ¹ / ₂	66	11 ¹ / ₂
S3-SCA1066	10	11 ¹ / ₂	66	12
S3-SCA1166	11	12 ¹ / ₂	66	12
S3-SCA1366	13	14 ¹ / ₂	66	12 ¹ / ₂
S3-SCA1466	14	15 ¹ / ₂	66	12 ¹ / ₂
S3-SCA1766	17	18 ¹ / ₂	66	13
S3-SCA0972	9	10 ¹ / ₂	72	13
S3-SCA1072	10	11 ¹ / ₂	72	13 ¹ / ₂
S3-SCA1172	11	12 ¹ / ₂	72	13 ¹ / ₂
S3-SCA1372	13	14 ¹ / ₂	72	14
S3-SCA1472	14	15 ¹ / ₂	72	14
S3-SCA1772	17	18 ¹ / ₂	72	14 ¹ / ₂
S3-SCA0978	9	10 ¹ / ₂	78	13 ¹ / ₂
S3-SCA1078	10	11 ¹ / ₂	78	14
S3-SCA1178	11	12 ¹ / ₂	78	14
S3-SCA1378	13	14 ¹ / ₂	78	14 ¹ / ₂
S3-SCA1478	14	15 ¹ / ₂	78	14 ¹ / ₂
S3-SCA1778	17	18 ¹ / ₂	78	15
S3-SCA0984	9	10 ¹ / ₂	84	14
S3-SCA1084	10	11 ¹ / ₂	84	14 ¹ / ₂
S3-SCA1184	11	12 ¹ / ₂	84	14 ¹ / ₂
S3-SCA1384	13	14 ¹ / ₂	84	15
S3-SCA1484	14	15 ¹ / ₂	84	15
S3-SCA1784	17	18 ¹ / ₂	84	15 ¹ / ₂
S3-SCA0990	9	10 ¹ / ₂	90	15
S3-SCA1090	10	11 ¹ / ₂	90	15 ¹ / ₂
S3-SCA1190	11	12 ¹ / ₂	90	15 ¹ / ₂
S3-SCA1390	13	14 ¹ / ₂	90	16
S3-SCA1490	14	15 ¹ / ₂	90	16
S3-SCA1790	17	18 ¹ / ₂	90	16 ¹ / ₂

Actual height of upright is 1" less than the nominal height. This allows for the leveler and 1/4" of adjustment.

System 30®

Column Assembly

Double Faced (1¹/₄ x 2¹/₂-14 gauge)

CATALOG NO.	NOMINAL SHELF DEPTH	OVERALL UPRIGHT DEPTH	NOMINAL HEIGHT	WEIGHT
S3-DCA1842	9	18 ¹ / ₂	42	9
S3-DCA2042	10	20 ¹ / ₂	42	9 ¹ / ₂
S3-DCA2242	11	22 ¹ / ₂	42	10
S3-DCA2642	13	26 ¹ / ₂	42	10 ¹ / ₂
S3-DCA2842	14	28 ¹ / ₂	42	10 ¹ / ₂
S3-DCA3442	17	34 ¹ / ₂	42	11 ¹ / ₂
S3-DCA1860	9	18 ¹ / ₂	60	13
S3-DCA2060	10	20 ¹ / ₂	60	13 ¹ / ₂
S3-DCA2260	11	22 ¹ / ₂	60	14
S3-DCA2660	13	26 ¹ / ₂	60	14 ¹ / ₂
S3-DCA2860	14	28 ¹ / ₂	60	14 ¹ / ₂
S3-DCA3460	17	34 ¹ / ₂	60	15 ¹ / ₂
S3-DCA1866	9	18 ¹ / ₂	66	14
S3-DCA2066	10	20 ¹ / ₂	66	14 ¹ / ₂
S3-DCA2266	11	22 ¹ / ₂	66	15
S3-DCA2666	13	26 ¹ / ₂	66	15 ¹ / ₂
S3-DCA2866	14	28 ¹ / ₂	66	15 ¹ / ₂
S3-DCA3466	17	34 ¹ / ₂	66	16 ¹ / ₂
S3-DCA1872	9	18 ¹ / ₂	72	14 ¹ / ₂
S3-DCA2072	10	20 ¹ / ₂	72	15
S3-DCA2272	11	22 ¹ / ₂	72	15 ¹ / ₂
S3-DCA2672	13	26 ¹ / ₂	72	16
S3-DCA2872	14	28 ¹ / ₂	72	16
S3-DCA3472	17	34 ¹ / ₂	72	17
S3-DCA1878	9	18 ¹ / ₂	78	15
S3-DCA2078	10	20 ¹ / ₂	78	15 ¹ / ₂
S3-DCA2278	11	22 ¹ / ₂	78	16
S3-DCA2678	13	26 ¹ / ₂	78	16 ¹ / ₂
S3-DCA2878	14	28 ¹ / ₂	78	16 ¹ / ₂
S3-DCA3478	17	34 ¹ / ₂	78	17 ¹ / ₂
S3-DCA1884	9	18 ¹ / ₂	84	16
S3-DCA2084	10	20 ¹ / ₂	84	16 ¹ / ₂
S3-DCA2284	11	22 ¹ / ₂	84	16 ¹ / ₂
S3-DCA2684	13	26 ¹ / ₂	84	17
S3-DCA2884	14	28 ¹ / ₂	84	17
S3-DCA3484	17	34 ¹ / ₂	84	18 ¹ / ₂
S3-DCA1890	9	18 ¹ / ₂	90	16 ¹ / ₂
S3-DCA2090	10	20 ¹ / ₂	90	17
S3-DCA2290	11	22 ¹ / ₂	90	17 ¹ / ₂
S3-DCA2690	13	26 ¹ / ₂	90	18
S3-DCA2890	14	28 ¹ / ₂	90	18
S3-DCA3490	17	34 ¹ / ₂	90	19

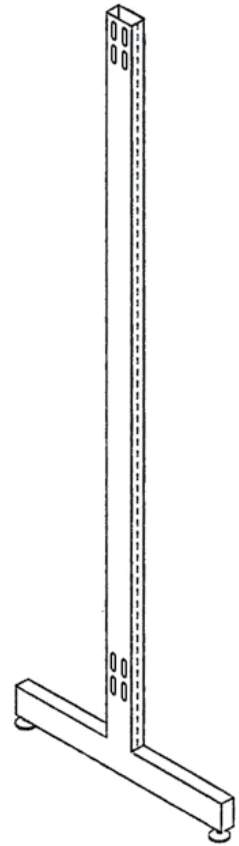

Actual height of upright is 1" less than the nominal height. This allows for the leveler and 1/4" of adjustment.

System 30®

Column Assembly

Double Faced (1¹/₄ x 2¹/₂–14 gauge for Seismic Zone 3)

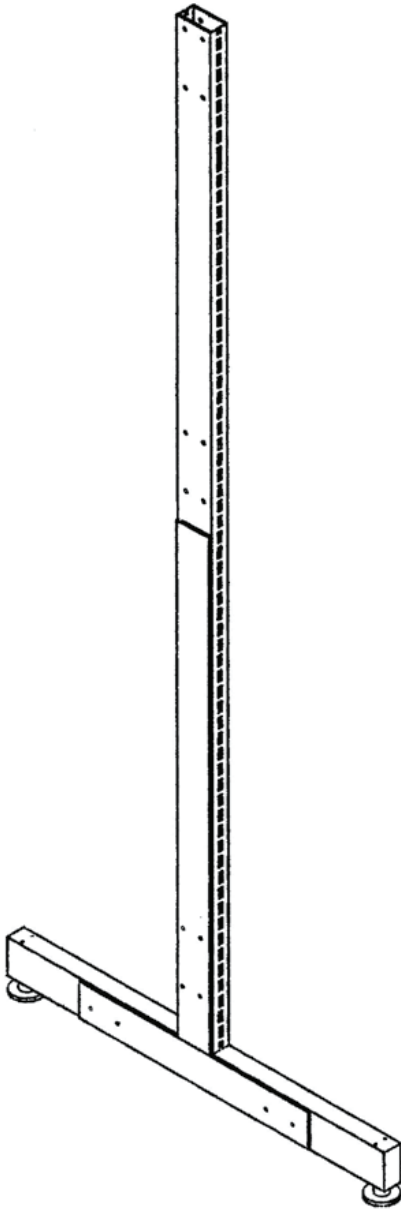

CATALOG NO.	NOMINAL SHELF DEPTH	OVERALL UPRIGHT DEPTH	NOMINAL HEIGHT	WEIGHT
S3-DCA1872-3	9	18 ¹ / ₂	72	25
S3-DCA2072-3	10	20 ¹ / ₂	72	26
S3-DCA2272-3	11	22 ¹ / ₂	72	27
S3-DCA2672-3	13	26 ¹ / ₂	72	28
S3-DCA2872-3	14	28 ¹ / ₂	72	29
S3-DCA3472-3	17	34 ¹ / ₂	72	31
S3-DCA1878-3	9	18 ¹ / ₂	78	25 ¹ / ₂
S3-DCA2078-3	10	20 ¹ / ₂	78	26 ¹ / ₂
S3-DCA2278-3	11	22 ¹ / ₂	78	27 ¹ / ₂
S3-DCA2678-3	13	26 ¹ / ₂	78	28 ¹ / ₂
S3-DCA2878-3	14	28 ¹ / ₂	78	29 ¹ / ₂
S3-DCA3478-3	17	34 ¹ / ₂	78	31 ¹ / ₂
S3-DCA1884-3	9	18 ¹ / ₂	84	26 ¹ / ₂
S3-DCA2084-3	10	20 ¹ / ₂	84	27 ¹ / ₂
S3-DCA2284-3	11	22 ¹ / ₂	84	28 ¹ / ₂
S3-DCA2684-3	13	26 ¹ / ₂	84	29 ¹ / ₂
S3-DCA2884-3	14	28 ¹ / ₂	84	30 ¹ / ₂
S3-DCA3484-3	17	34 ¹ / ₂	84	32 ¹ / ₂
S3-DCA1890-3	9	18 ¹ / ₂	90	28
S3-DCA2090-3	10	20 ¹ / ₂	90	29
S3-DCA2290-3	11	22 ¹ / ₂	90	30
S3-DCA2690-3	13	26 ¹ / ₂	90	31
S3-DCA2890-3	14	28 ¹ / ₂	90	32
S3-DCA3490-3	17	34 ¹ / ₂	90	34

To meet seismic zone 3 requirements, use the above special column assemblies along with seismic middle cross bar and seismic bottom cross bar as shown on page 18. The top cross bar can be our standard cross bar. In addition to this, the units must be floor anchored at the outer end of each upright assembly. A special angle plate is furnished which is attached to the upright assemblies with 1/4" machine bolts. Floor anchors are not included.

System 30®

Column Assembly

Double Faced (1¹/₄ x 2¹/₂–14 gauge for Seismic Zone 4)

CATALOG NO.	NOMINAL SHELF DEPTH	OVERALL UPRIGHT DEPTH	NOMINAL HEIGHT	WEIGHT
S3-DCA1872-4	9	18 ¹ / ₂	72	24
S3-DCA2072-4	10	20 ¹ / ₂	72	25
S3-DCA2272-4	11	22 ¹ / ₂	72	26
S3-DCA2672-4	13	26 ¹ / ₂	72	28
S3-DCA2872-4	14	28 ¹ / ₂	72	30
S3-DCA3472-4	17	34 ¹ / ₂	72	33
S3-DCA1878-4	9	18 ¹ / ₂	78	24 ¹ / ₂
S3-DCA2078-4	10	20 ¹ / ₂	78	25 ¹ / ₂
S3-DCA2278-4	11	22 ¹ / ₂	78	26 ¹ / ₂
S3-DCA2678-4	13	26 ¹ / ₂	78	28 ¹ / ₂
S3-DCA2878-4	14	28 ¹ / ₂	78	30 ¹ / ₂
S3-DCA3478-4	17	34 ¹ / ₂	78	33 ¹ / ₂
S3-DCA1884-4	9	18 ¹ / ₂	84	25 ¹ / ₂
S3-DCA2084-4	10	20 ¹ / ₂	84	26 ¹ / ₂
S3-DCA2284-4	11	22 ¹ / ₂	84	27 ¹ / ₂
S3-DCA2684-4	13	26 ¹ / ₂	84	29 ¹ / ₂
S3-DCA2884-4	14	28 ¹ / ₂	84	31 ¹ / ₂
S3-DCA3484-4	17	34 ¹ / ₂	84	34 ¹ / ₂
S3-DCA1890-4	9	18 ¹ / ₂	90	26
S3-DCA2090-4	10	20 ¹ / ₂	90	27
S3-DCA2290-4	11	22 ¹ / ₂	90	28
S3-DCA2690-4	13	26 ¹ / ₂	90	30 ¹ / ₂
S3-DCA2890-4	14	28 ¹ / ₂	90	32
S3-DCA3490-4	17	34 ¹ / ₂	90	35

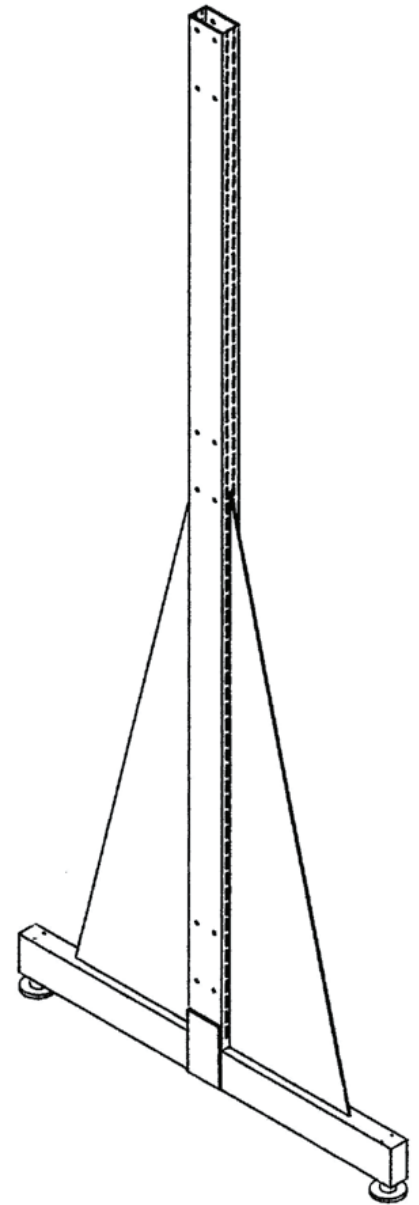

To meet seismic zone 4 requirements, use the above special column assemblies along with seismic top and bottom cross bars as shown on page 18. Sway braces must be added at a minimum of every 4th section (call for pricing). In addition to this the units must be floor anchored at the outer end of each upright assembly. A special angle plate is furnished which is attached to the upright assemblies with tek screws. Floor anchors are not included. Must order special kick plates as shown on page 18. Uprights are double slotted instead of single slotted. Gussets are welded to the upright assemblies except at ends of ranges where a steel plate is welded to the upright in lieu of a gusset.

System 30®

Cross Bars

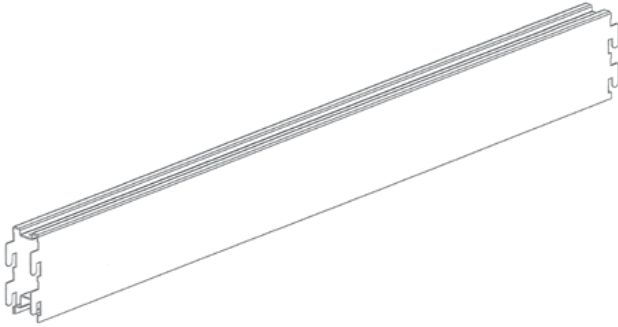

3 x 1 x 14 Gauge Open Channel

CATALOG NO.	SIZE	WEIGHT
S3-CROSS30	30	5
S3-CROSS36	36	6

Two cross bars are needed per section.

Use in seismic zones 1, 2a, 2b, and on top in seismic zone 3.

3 x 1 x 16 Gauge Open Channel (Seismic Zone 4)

CATALOG NO.	SIZE	WEIGHT
S3-CROSS30-4	30	4
S3-CROSS36-4	36	5

Use at top and the bottom in seismic zone 4 only.

Middle/Bottom Cross Bars

3 x 1 x 14 Gauge Closed Tube (Seismic Zone 3)

CATALOG NO.	SIZE	WEIGHT
S3-CROSS30-3	30	6
S3-CROSS36-3	36	7

Use in the middle and the bottom in seismic zone 3 only.

Kick Plate

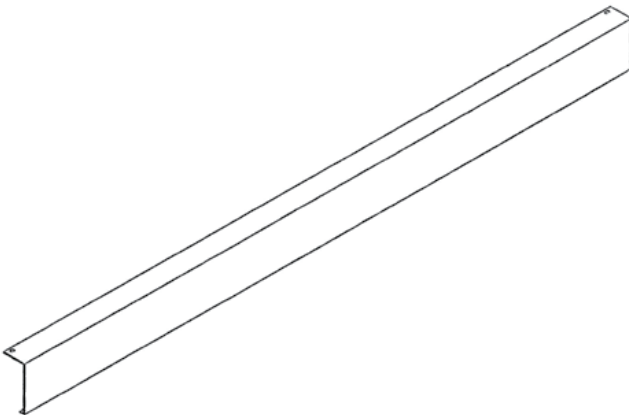

2 1/2" High x 20 Gauge

CATALOG NO.	SIZE	WEIGHT
S3-KP30	30	1 1/2
S3-KP36	36	1 1/2

One kick plate is used on single faced units and two on double face.

Kick plate attaches with 2 drop in rivets.

For Seismic Zone 4

CATALOG NO.	SIZE	WEIGHT
S3-KP30-S	30	1 1/2
S3-KP36-S	36	1 1/2

Use in seismic zone 4 only.

System 30®

Integral Back Shelves

1 1/4" High Back Edge

CATALOG NO.	SIZE	WEIGHT
S3-INT3009	30 x 9	6 1/2
S3-INT3010	30 x 10	7
S3-INT3011	30 x 11	8
S3-INT3013	30 x 13	9
S3-INT3017	30 x 17	11
S3-INT3609	36 x 9	7 1/2
S3-INT3610	36 x 10	8
S3-INT3611	36 x 11	8 1/2
S3-INT3613	36 x 13	10
S3-INT3617	36 x 17	12

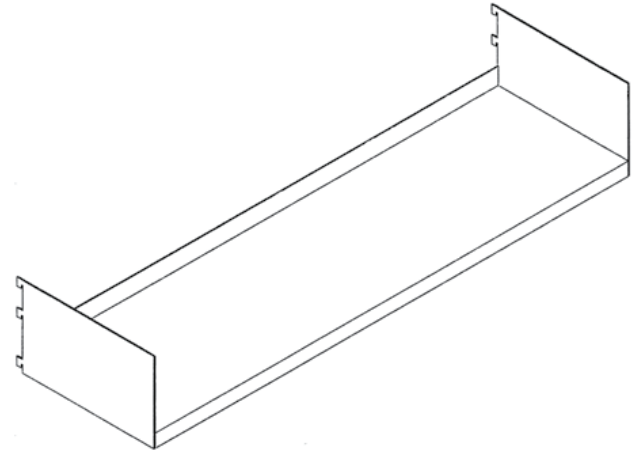

Includes 6" high flat end brackets.
Add an (s) after the catalog number if used with seismic zone 4 column assemblies.

Standard Flat Shelves

CATALOG NO.	SIZE	WEIGHT
S3-AS3009	30 x 9	6 1/2
S3-AS3010	30 x 10	7
S3-AS3011	30 x 11	8
S3-AS3013	30 x 13	9
S3-AS3017	30 x 17	11
S3-AS3609	36 x 9	7 1/2
S3-AS3610	36 x 10	8
S3-AS3611	36 x 11	8 1/2
S3-AS3613	36 x 13	9
S3-AS3617	36 x 17	11

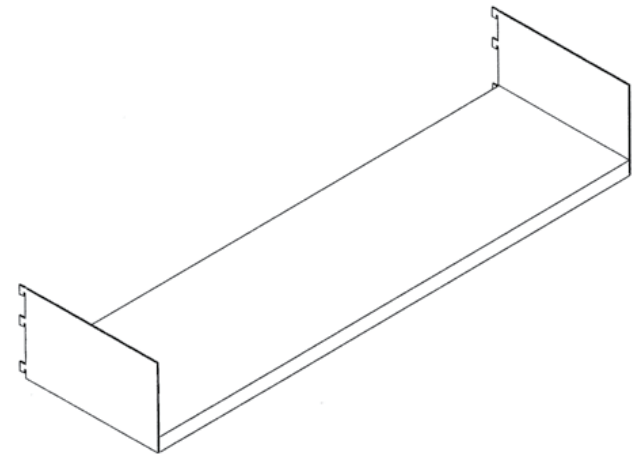

Includes 6" high flat end brackets.
Add an (s) after the catalog number if used with seismic zone 4 column assemblies.

All sizes shown are nominal. Over all shelf size is 1" less than nominal.

System 30®

Adjustable Backstop

CATALOG NO.	SIZE	WEIGHT
S3-BSTOP36	36"	2

Used with standard flat shelves to prevent material from sliding through to the other side of a double face unit.

Divider Shelves

Comes with 3 dividers per shelf

CATALOG NO.	SIZE	WEIGHT
S3-DIV3010	30 x 10	16
S3-DIV3013	30 x 13	19
S3-DIV3610	36 x 10	17
S3-DIV3613	36 x 13	20

Includes 8" high flat end brackets.

Dividers

CATALOG NO.	SIZE	WEIGHT
S3-DIV78	7 x 8	1
S3-DIV711	7 x 11	1

Hinged Periodical Shelves

With Integral Back Shelf

CATALOG NO.	SIZE	WEIGHT
S3-HIN3614	36 x 14	17
S3-HIN3617	36 x 17	20

Includes 8" high flat end brackets. Back issues are stored out of sight behind the sloped display shelf. Display shelf is 14" high.

Hinged Periodical Shelves

With Plexiglass Covers

CATALOG NO.	SIZE	WEIGHT
S3-HIN3614PLEX	36 x 14	19
S3-HIN3617PLEX	36 x 17	22

Ideal for displaying and storing newspapers.

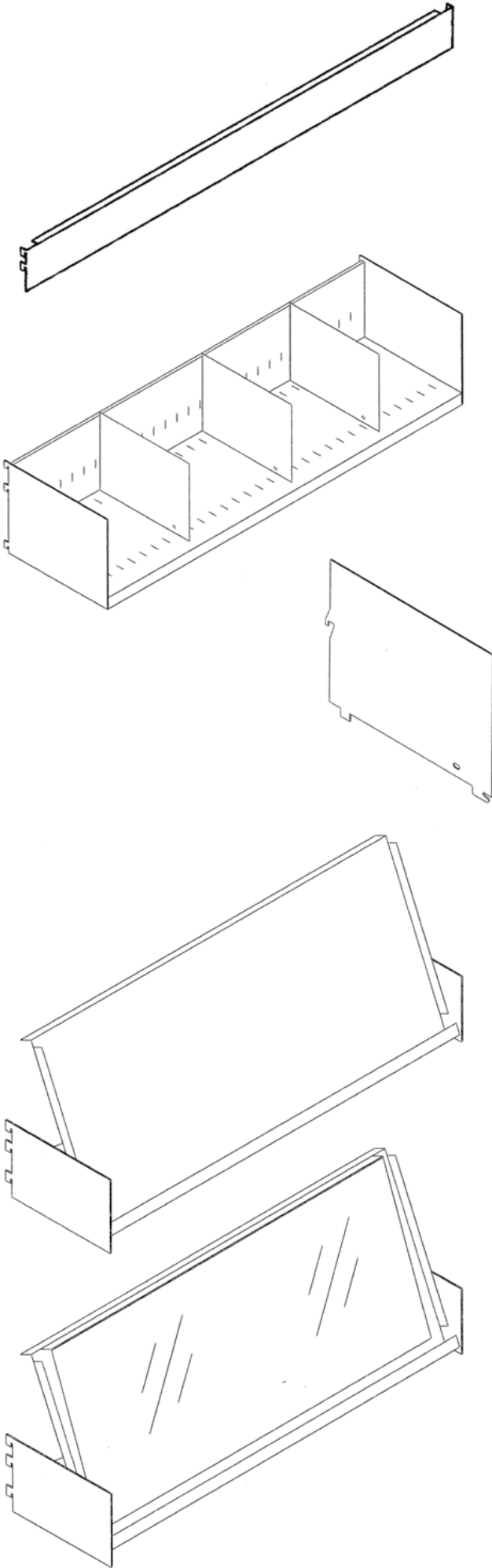

System 30®

Tip-Up Periodical Cabinet

CATALOG NO.	SIZE	WEIGHT
S3-PERCAB3617	36 x 17	38

Ideal for increased storage of back issues. Provides up to 12¹/₂" of storage height. Ideal for storing back issues in Princeton type boxes. 11 boxes will fit on a shelf.

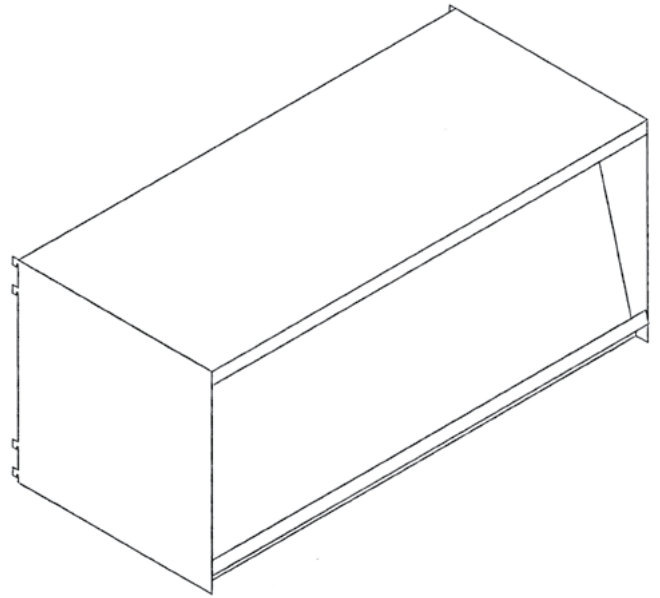

Fixed Periodical Shelves

CATALOG NO.	SIZE	SLOPE	WEIGHT
S3-FIX3613-30	36 x 13	30°	9 ¹ / ₂
S3-FIX3613-45	36 x 13	45°	9 ¹ / ₂

Includes brackets. Ideal for displaying periodicals. Back issues are stored on our storage shelf which must be ordered separately. Display shelf is 11" high with 1" front flange.

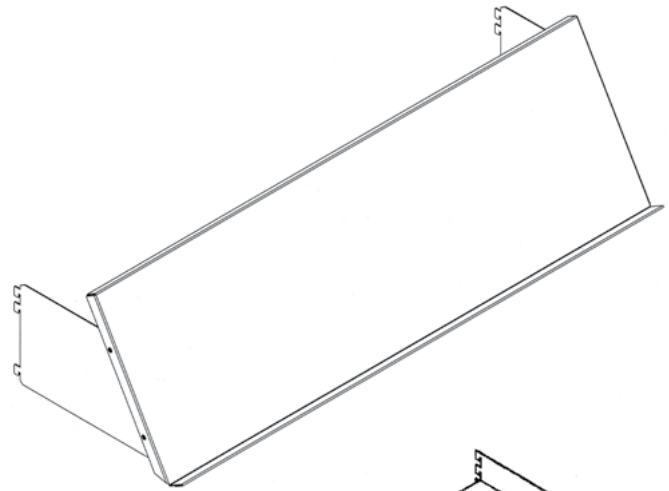

Storage Shelf

CATALOG NO.	SIZE	WEIGHT
S3-STOR3612	36 x 12	10

Includes brackets. Used in conjunction with fixed periodical shelf for storage of back issues.

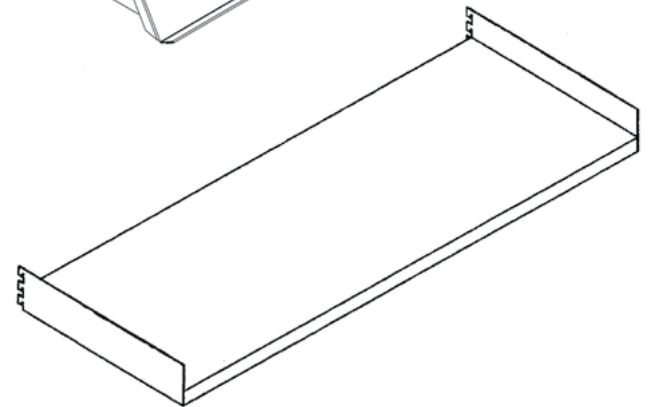

Sliding Reference Shelf

CATALOG NO.	SIZE	WEIGHT
S3-REF3609	36 x 9	10
S3-REF3610	36 x 10	10 ¹ / ₂
S3-REF3611	36 x 11	11
S3-REF3613	36 x 13	11
S3-REF3617	36 x 17	12

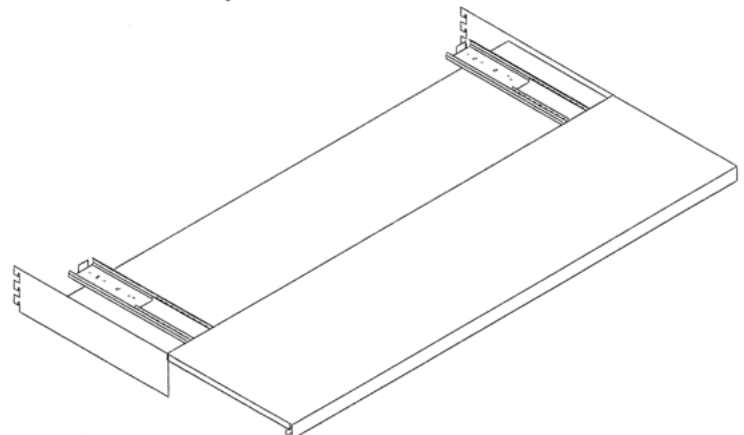

System 30®

Multi Media Display Shelf

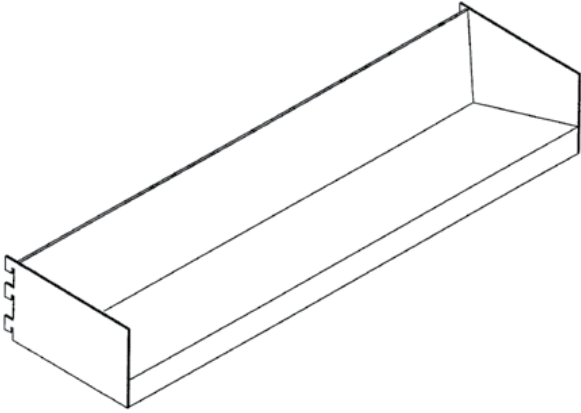

CATALOG NO.	SIZE	WEIGHT
S3-PB3609	36 x 9	12

Comes complete with 8" high end brackets. Flat surface of shelf measures 6" deep. Ideal for storage/display of CDs, videos and paperback books.

Can also be furnished with slots on 1" centers and 5 dividers. Order as follows:

CATALOG NO.	SIZE	WEIGHT
S3-PB3609-DIV	36 x 9	15

Will hold 85 CDs per shelf or 28 videos.

Double Tier Cassette Shelf

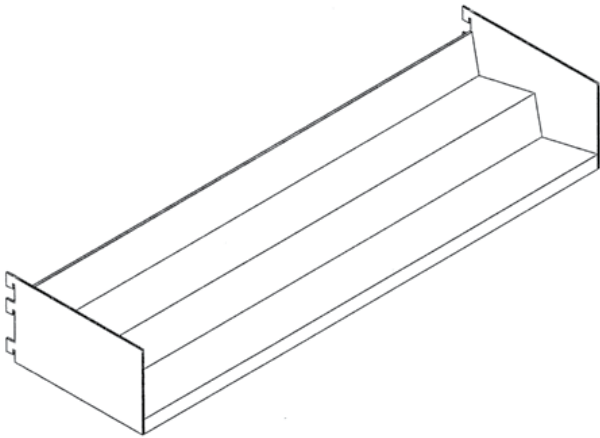

CATALOG NO.	SIZE	WEIGHT
S3-DT3610	36 x 10	9½

Includes brackets. Will hold 102 cassettes.

Sliding Door Cabinet 2 Sliding Doors

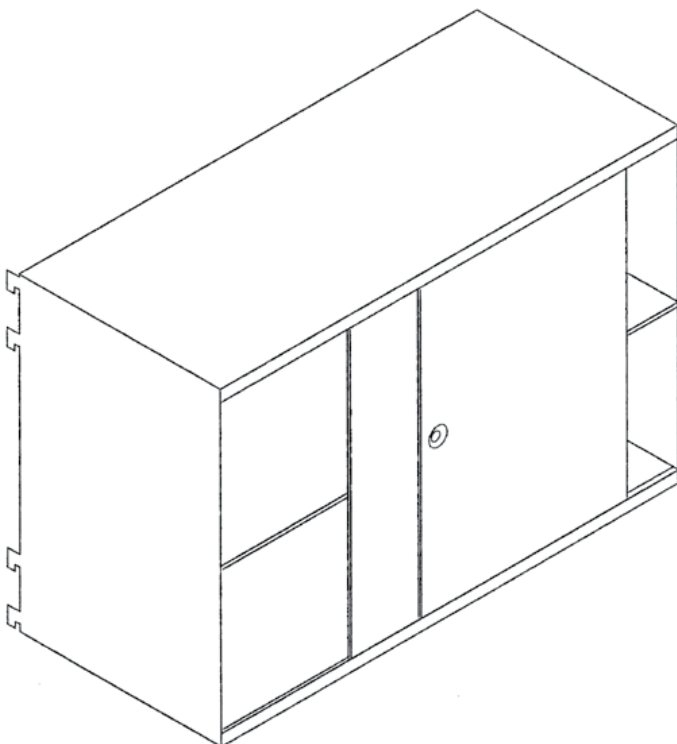

CATALOG NO.	SIZE	WEIGHT
S3-SSCAB361724	36w x 17d x 24h	65

Comes with lock and one adjustable shelf.

System 30®

Multi-Media Cabinet

CATALOG NO.	SIZE	WEIGHT
S3-MMCAB36	36 x 17	53

Includes lock.

S3-MMCAB36-1	36 x 17	59
--------------	---------	----

Includes lock and one pull-out frame.

S3-MMCAB36-2	36 x 17	65
--------------	---------	----

Includes lock and two pull-out frames.

Door slides up and out of view for easy access to storage trays. Trays must be ordered separately. Cabinet measures 36"w x 16"h x 16"d.

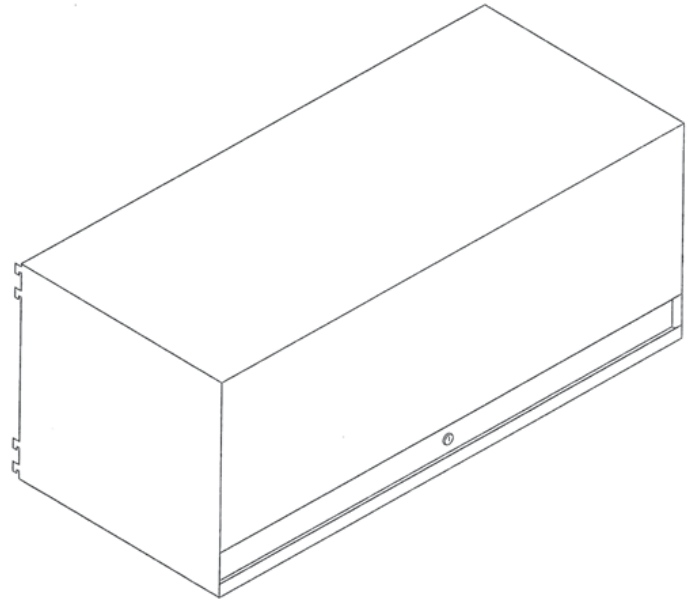

Cabinet Storage Trays

Each tray comes with one divider.

CATALOG NO.	SIZE	WEIGHT
S3-CASSETTE	3 x 4 ⁷ / ₁₆ x 12 ³ / ₄	3

Each tray will hold 18 audio cassettes.
Each pull-out frame will hold 7 trays.

S3-VIDEO	3 ¹ / ₄ x 7 ⁵ / ₈ x 12 ³ / ₄	4
----------	--	---

Each tray will hold 11 video cassettes.
Each pull-out frame will hold 4 trays.

S3-MICROFILM	3 ⁷ / ₈ x 4 x 12 ³ / ₄	3
--------------	--	---

Each tray will hold 7 boxes.
Each pull-out frame will hold 8 trays.

S3-MICROFICHE	4 x 6 ¹ / ₈ x 12 ³ / ₄	4
---------------	--	---

Each tray will hold 905 microfiches.
Each pull-out frame will hold 5 trays.

S3-CD	4 ¹ / ₂ x 5 x 12 ³ / ₄	4
-------	--	---

Each tray will hold 29 CDs.
Each pull-out frame will hold 6 trays.

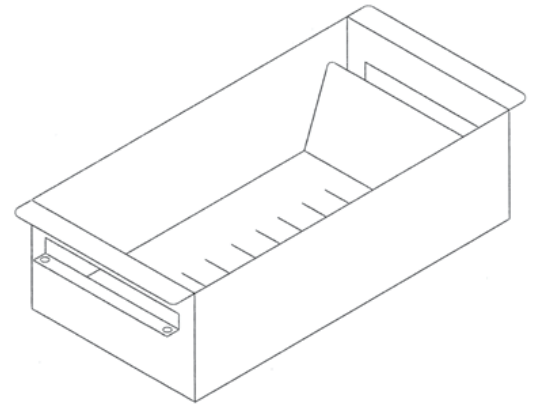

System 30®

Browsing Boxes for Audio/Visual Media

Single Tier Browsing Box for Audio Cassettes

CATALOG NO.	SIZE	WEIGHT
S3-STBROWSE3613-AC	36 x 13 x 4	17

Box has 10 compartments for audio cassettes.
Capacity: 120 audio cassettes.

Single Tier Browsing Box for CDs

CATALOG NO.	SIZE	WEIGHT
S3-STBROWSE3613-CD	36 x 13 x 4	17

Box has 6 compartments for CDs.
Capacity: 114 CDs.

Single Tier Browsing Box for DVDs

CATALOG NO.	SIZE	WEIGHT
S3-STBROWSE3613-DVD	36 x 13 x 4	17

Box has 6 compartments for DVDs.
Capacity: 72 DVDs.

Single Tier Pull-Out Browsing Box

All of our browsing boxes can be made in a pull out design. Capacities are the same as the regular browsing box. Simply add the letters PO after the catalog numbers listed above.

System 30®

Double Tier Browsing Box for Audio Cassettes

CATALOG NO.	SIZE	WEIGHT
S3-DTBROWSE3617-AC	36 x 17 X 8	29

Box has 20 compartments for audio cassettes.
Capacity: 160 audio cassettes.

Double Tier Browsing Box for CDs

CATALOG NO.	SIZE	WEIGHT
S3-DTBROWSE3617-CD	36 x 17 X 8	29

Box has 12 compartments for CDs.
Capacity: 144 CDs.

All of our browsing boxes are designed to be adjustable in the field.

Double Tier Pull-Out Browsing Box

All of our browsing boxes can be made in a pull out design.
Capacities are the same as the regular browsing box.
Simply add the letters PO after the catalog numbers listed above.

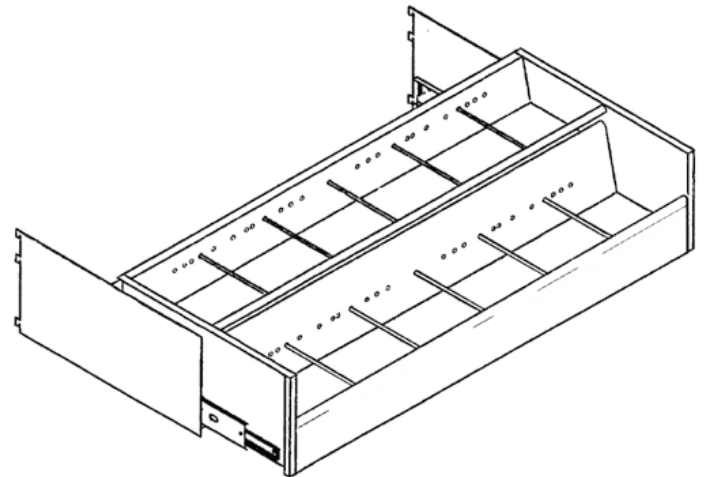
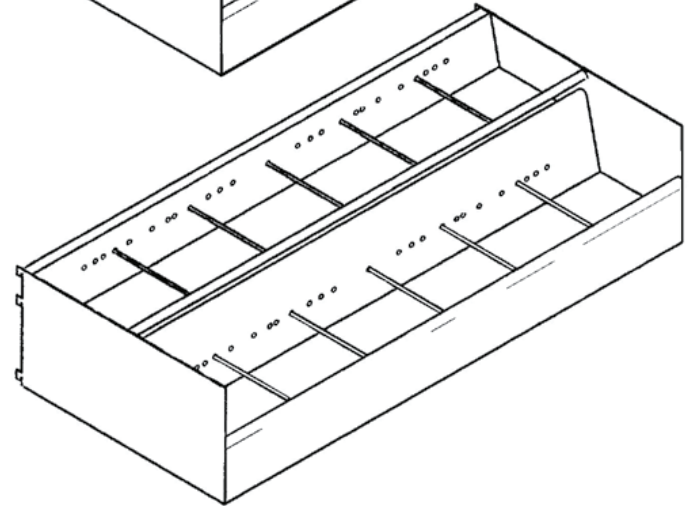
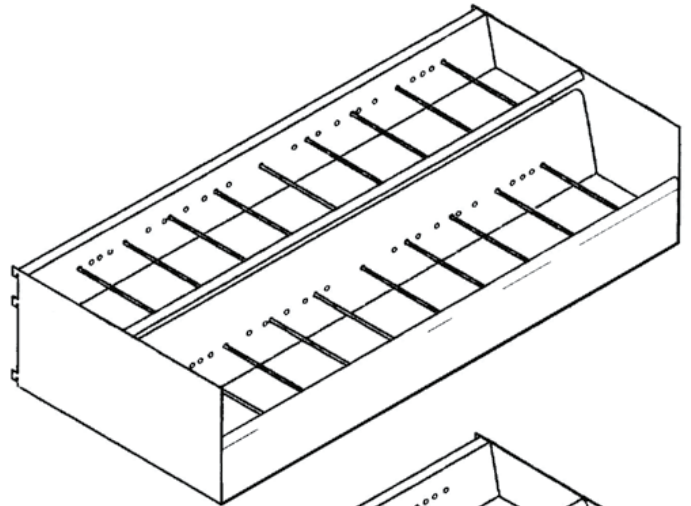

System 30®

Hang-Up Bag Rack

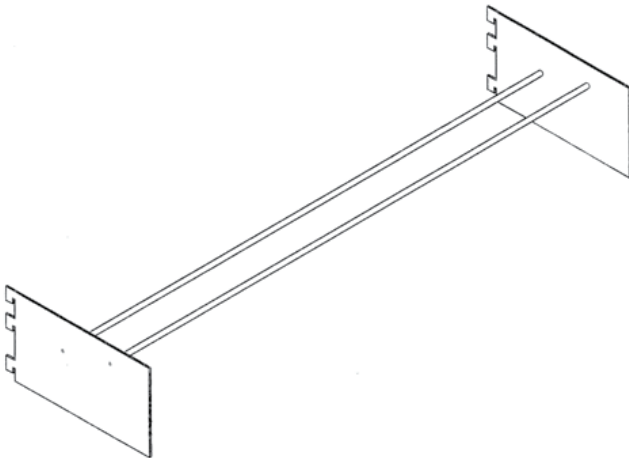

CATALOG NO.	SIZE	WEIGHT
S3-BAG3612	36 x 12	4

Rod measures 7/16" in Diameter. Hang-up bags hang on front rod. Back rod prevents bags from swinging. Will accept most size bags. Ideal for storage of odd size materials.

Zig-Zag Display

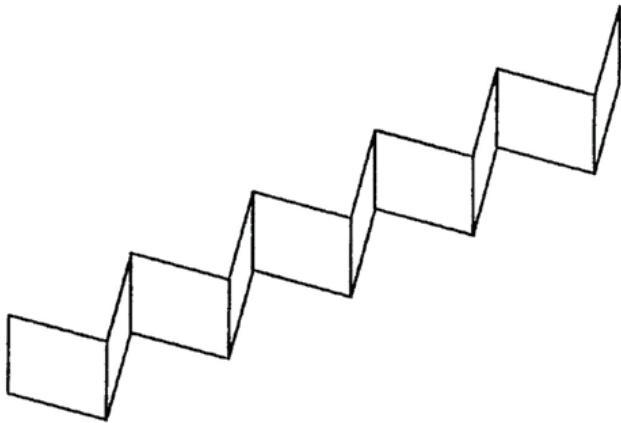

CATALOG NO.	SIZE	WEIGHT
S3-ZIGZAG36	36 x 4	3

Includes zig-zag only. Shelf must be ordered separately. Attaches to shelf with small angle brackets and double sided tape.

Display System

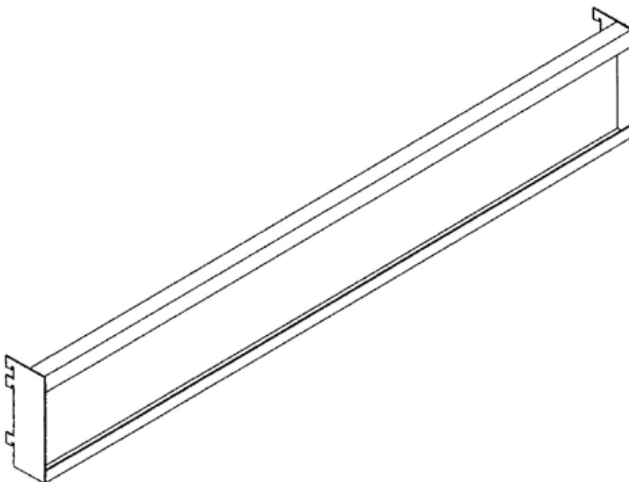

CATALOG NO.	SIZE	WEIGHT
S3-DIS3606-AC	36 x 5 ⁵ / ₈	6
S3-DIS3607-CD	36 x 5 ¹¹ / ₁₆	7
S3-DIS3609-DVD	36 x 8 ¹ / ₄	10

Used to display cassettes, CDs, DVDs in an upright position. Ideal for use above browsing boxes.

System 30®

Steel Canopy Tops

Starter Unit Single Faced

CATALOG NO.	SIZE	WEIGHT
S3-TOP3609-S	36 x 9	6
S3-TOP3610-S	36 x 10	6½
S3-TOP3611-S	36 x 11	7
S3-TOP3613-S	36 x 13	8
S3-TOP3617-S	36 x 17	9½

Starter canopy top comes with 1 pair of brackets.

Adder Unit Single Faced

CATALOG NO.	SIZE	WEIGHT
S3-TOP3609-A	36 x 9	5
S3-TOP3610-A	36 x 10	5½
S3-TOP3611-A	36 x 11	6
S3-TOP3613-A	36 x 13	7
S3-TOP3617-A	36 x 17	8½

Adder single faced canopy top comes with 1 bracket only.

Starter Unit Double Faced

CATALOG NO.	SIZE	WEIGHT
S3-TOP3618-S	36 x 18	12
S3-TOP3620-S	36 x 20	13
S3-TOP3622-S	36 x 22	14
S3-TOP3626-S	36 x 26	16
S3-TOP3634-S	36 x 34	19

Starter canopy top comes with 2 pairs of brackets.

Adder Unit Double Faced

CATALOG NO.	SIZE	WEIGHT
S3-TOP3618-A	36 x 18	10
S3-TOP3620-A	36 x 20	11
S3-TOP3622-A	36 x 22	12
S3-TOP3626-A	36 x 26	14
S3-TOP3634-A	36 x 34	17

Adder double face canopy top comes with 2 brackets only.

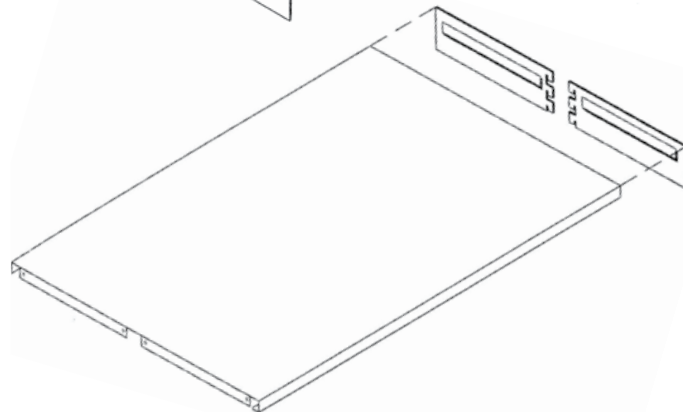
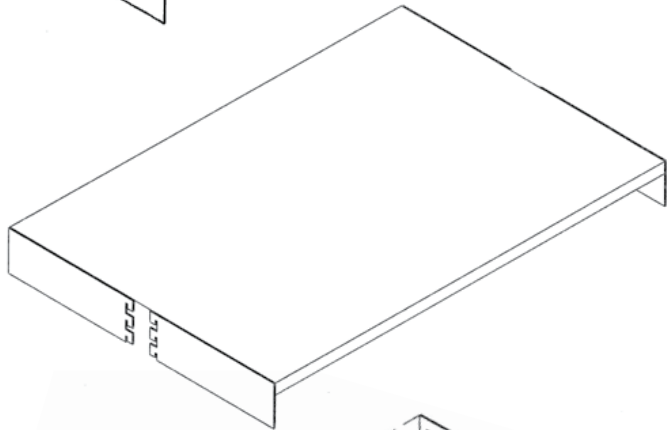
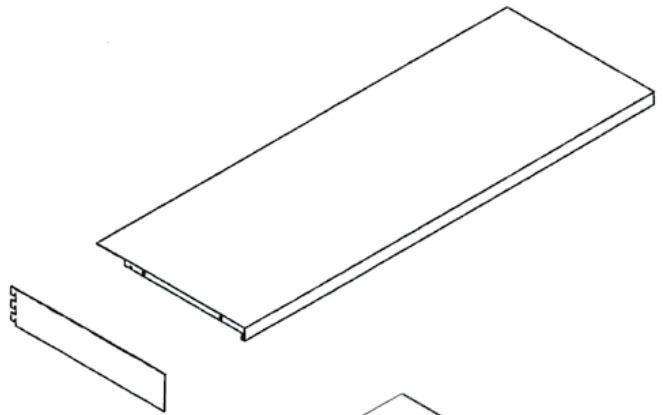
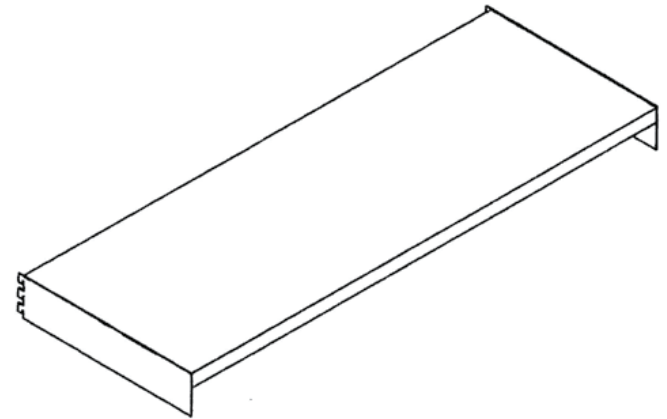

System 30®

Steel End Panels

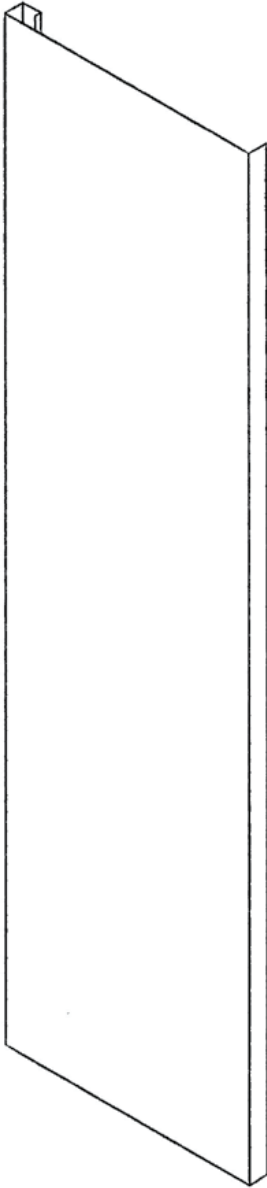

Single Faced

CATALOG NO.	SIZE	WEIGHT
S3-END0942	10 ⁹ / ₁₆ X 40 ⁵ / ₈	11
S3-END1042	11 ⁹ / ₁₆ X 40 ⁵ / ₈	12
S3-END1142	12 ⁹ / ₁₆ X 40 ⁵ / ₈	13
S3-END1342	14 ⁹ / ₁₆ X 40 ⁵ / ₈	14
S3-END1442HP	15 ⁹ / ₁₆ X 40 ⁵ / ₈	15
S3-END1742	18 ⁹ / ₁₆ X 40 ⁵ / ₈	17
S3-END0960	10 ⁹ / ₁₆ X 58 ⁵ / ₈	16
S3-END1060	11 ⁹ / ₁₆ X 58 ⁵ / ₈	17
S3-END1160	12 ⁹ / ₁₆ X 58 ⁵ / ₈	18
S3-END1360	14 ⁹ / ₁₆ X 58 ⁵ / ₈	19 ¹ / ₂
S3-END1460HP	15 ⁹ / ₁₆ X 58 ⁵ / ₈	20 ¹ / ₂
S3-END1760	18 ⁹ / ₁₆ X 58 ⁵ / ₈	24
S3-END0966	10 ⁹ / ₁₆ X 64 ⁵ / ₈	18
S3-END1066	11 ⁹ / ₁₆ X 64 ⁵ / ₈	19
S3-END1166	12 ⁹ / ₁₆ X 64 ⁵ / ₈	20
S3-END1366	14 ⁹ / ₁₆ X 64 ⁵ / ₈	21 ¹ / ₂
S3-END1466HP	15 ⁹ / ₁₆ X 64 ⁵ / ₈	22 ¹ / ₂
S3-END1766	18 ⁹ / ₁₆ X 64 ⁵ / ₈	26
S3-END0972	10 ⁹ / ₁₆ X 70 ⁵ / ₈	20
S3-END1072	11 ⁹ / ₁₆ X 70 ⁵ / ₈	21
S3-END1172	12 ⁹ / ₁₆ X 70 ⁵ / ₈	22
S3-END1372	14 ⁹ / ₁₆ X 70 ⁵ / ₈	24
S3-END1472HP	15 ⁹ / ₁₆ X 70 ⁵ / ₈	25
S3-END1772	18 ⁹ / ₁₆ X 70 ⁵ / ₈	29
S3-END0978	10 ⁹ / ₁₆ X 76 ⁵ / ₈	22
S3-END1078	11 ⁹ / ₁₆ X 76 ⁵ / ₈	23
S3-END1178	12 ⁹ / ₁₆ X 76 ⁵ / ₈	24
S3-END1378	14 ⁹ / ₁₆ X 76 ⁵ / ₈	26
S3-END1478HP	15 ⁹ / ₁₆ X 76 ⁵ / ₈	27
S3-END1778	18 ⁹ / ₁₆ X 76 ⁵ / ₈	31
S3-END0984	10 ⁹ / ₁₆ X 82 ⁵ / ₈	24
S3-END1084	11 ⁹ / ₁₆ X 82 ⁵ / ₈	24 ¹ / ₂
S3-END1184	12 ⁹ / ₁₆ X 82 ⁵ / ₈	25 ¹ / ₂
S3-END1384	14 ⁹ / ₁₆ X 82 ⁵ / ₈	27 ¹ / ₂
S3-END1484HP	15 ⁹ / ₁₆ X 82 ⁵ / ₈	28 ¹ / ₂
S3-END1784	18 ⁹ / ₁₆ X 82 ⁵ / ₈	33
S3-END0990	10 ⁹ / ₁₆ X 88 ⁵ / ₈	25
S3-END1090	11 ⁹ / ₁₆ X 88 ⁵ / ₈	26
S3-END1190	12 ⁹ / ₁₆ X 88 ⁵ / ₈	27
S3-END1390	14 ⁹ / ₁₆ X 88 ⁵ / ₈	29
S3-END1490HP	15 ⁹ / ₁₆ X 88 ⁵ / ₈	30
S3-END1790	18 ⁹ / ₁₆ X 88 ⁵ / ₈	36

Each end panel will add ⁷/₁₆" to the length of a range.
Must specify left hand or right hand when ordering.

System 30®

Steel End Panels

Double Faced

CATALOG NO.	SIZE	WEIGHT
S3-END1842	18 ¹ / ₂ x 40 ⁵ / ₈	20
S3-END2042	20 ¹ / ₂ x 40 ⁵ / ₈	21
S3-END2242	22 ¹ / ₂ x 40 ⁵ / ₈	22
S3-END2642	26 ¹ / ₂ x 40 ⁵ / ₈	24
S3-END2842HP	28 ¹ / ₂ x 40 ⁵ / ₈	26
S3-END3442	34 ¹ / ₂ x 40 ⁵ / ₈	31
S3-END1860	18 ¹ / ₂ x 58 ⁵ / ₈	29
S3-END2060	20 ¹ / ₂ x 58 ⁵ / ₈	30
S3-END2260	22 ¹ / ₂ x 58 ⁵ / ₈	32
S3-END2660	26 ¹ / ₂ x 58 ⁵ / ₈	35
S3-END2860HP	28 ¹ / ₂ x 58 ⁵ / ₈	37
S3-END3460	34 ¹ / ₂ x 58 ⁵ / ₈	42
S3-END1866	18 ¹ / ₂ x 64 ⁵ / ₈	31
S3-END2066	20 ¹ / ₂ x 64 ⁵ / ₈	32
S3-END2266	22 ¹ / ₂ x 64 ⁵ / ₈	34
S3-END2666	26 ¹ / ₂ x 64 ⁵ / ₈	37
S3-END2866HP	28 ¹ / ₂ x 64 ⁵ / ₈	39
S3-END3466	34 1/2 x 64 ⁵ / ₈	44
S3-END1872	18 ¹ / ₂ x 70 ⁵ / ₈	36
S3-END2072	20 ¹ / ₂ x 70 ⁵ / ₈	37
S3-END2272	22 ¹ / ₂ x 70 ⁵ / ₈	39
S3-END2672	26 ¹ / ₂ x 70 ⁵ / ₈	42
S3-END2872HP	28 ¹ / ₂ x 70 ⁵ / ₈	44
S3-END3472	34 ¹ / ₂ x 70 ⁵ / ₈	49
S3-END1878	18 ¹ / ₂ x 76 ⁵ / ₈	38
S3-END2078	20 ¹ / ₂ x 76 ⁵ / ₈	39
S3-END2278	22 ¹ / ₂ x 76 ⁵ / ₈	41
S3-END2678	26 ¹ / ₂ x 76 ⁵ / ₈	44
S3-END2878HP	28 ¹ / ₂ x 76 ⁵ / ₈	46
S3-END3478	34 ¹ / ₂ x 76 ⁵ / ₈	51
S3-END1884	18 ¹ / ₂ x 82 ⁵ / ₈	40
S3-END2084	20 ¹ / ₂ x 82 ⁵ / ₈	41
S3-END2284	22 ¹ / ₂ x 82 ⁵ / ₈	43
S3-END2684	26 ¹ / ₂ x 82 ⁵ / ₈	47
S3-END2884HP	28 ¹ / ₂ x 82 ⁵ / ₈	49
S3-END3484	34 ¹ / ₂ x 82 ⁵ / ₈	54
S3-END1890	18 ¹ / ₂ x 88 ⁵ / ₈	43
S3-END2090	20 ¹ / ₂ x 88 ⁵ / ₈	44
S3-END2290	22 ¹ / ₂ x 88 ⁵ / ₈	46
S3-END2690	26 ¹ / ₂ x 88 ⁵ / ₈	51
S3-END2890HP	28 ¹ / ₂ x 88 ⁵ / ₈	53
S3-END3490	34 ¹ / ₂ x 88 ⁵ / ₈	58

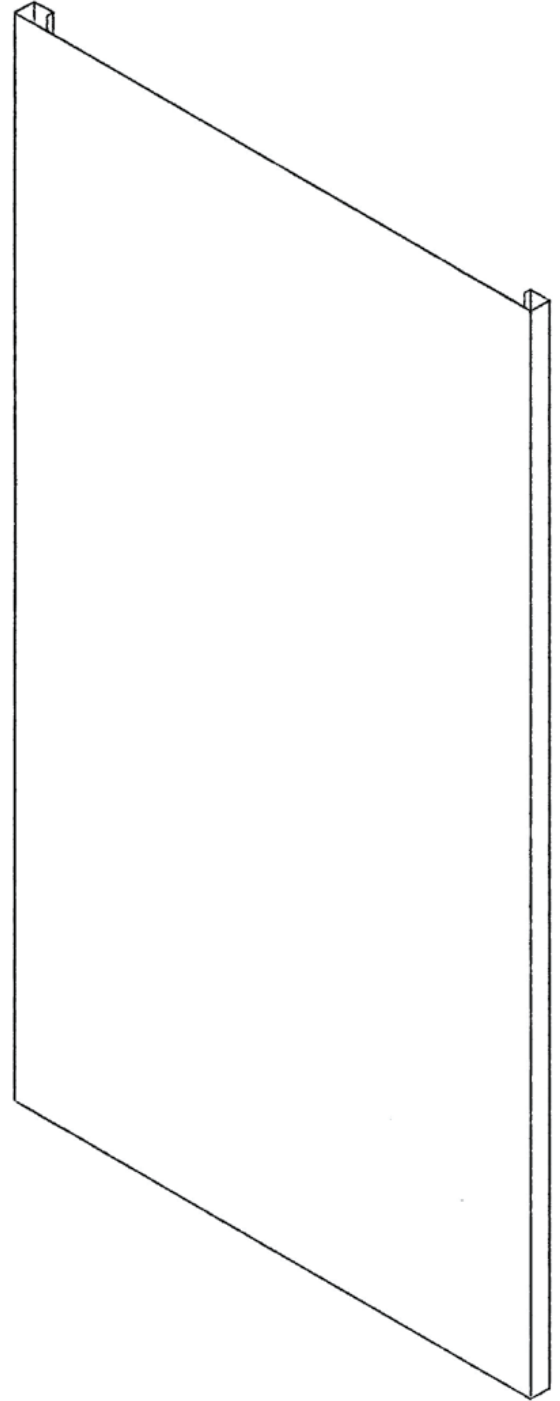

Each end panel will add 7/16" to the length of a range.

System 30®

Brackets For Wood End Panels

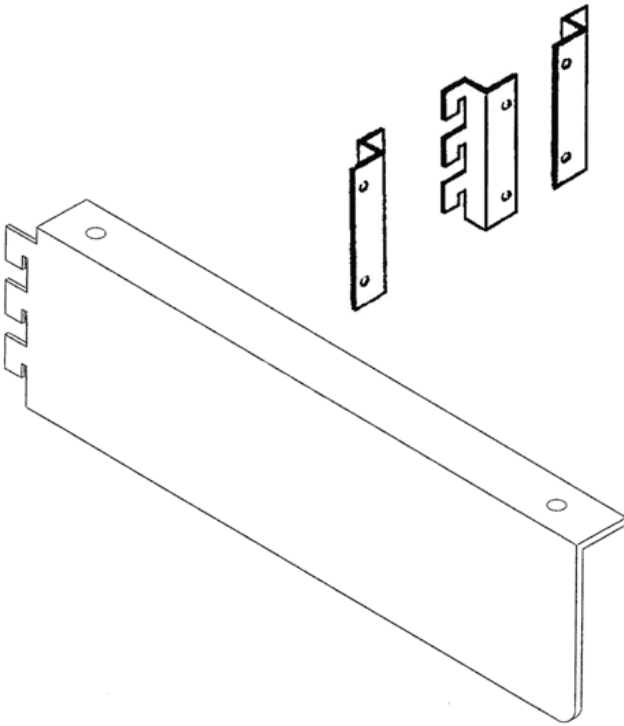

CATALOG NO.	SIZE	WEIGHT
S3-WOODEPBKT-SF	SF	5
S3-WOODEPBKT-DF	DF	7

Brackets For Wood Tops

Come in pairs

CATALOG NO.	SIZE	WEIGHT
S3-WOODBKT9	9	1½

This size is used on all depth units.

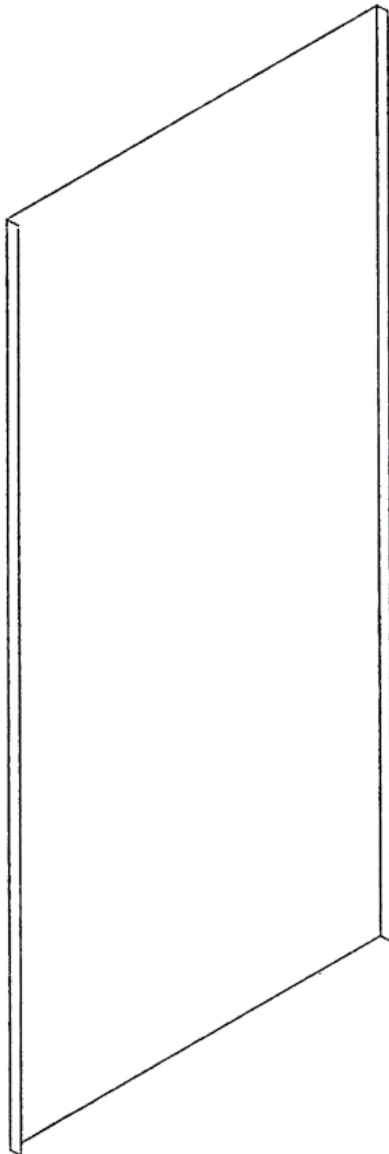

Closed Backs

CATALOG NO.	SIZE	WEIGHT
S3-BACK3642	36 x 42	23
S3-BACK3660	36 x 60	35
S3-BACK3666	36 x 66	39
S3-BACK3672	36 x 72	42½
S3-BACK3678	36 x 78	45
S3-BACK3684	36 x 84	46½
S3-BACK3690	36 x 90	54

Closed backs fit between top and bottom cross bars.
Actual height of closed back is 9¾" less than the nominal height of the unit.

System 30®

Corner Filler

CATALOG NO.	SIZE	WEIGHT
S3-CORNER	SPECIFY	78

Filler comes complete with two sides and a top cap. Used in corner to fill in the space where two single faced units meet together.

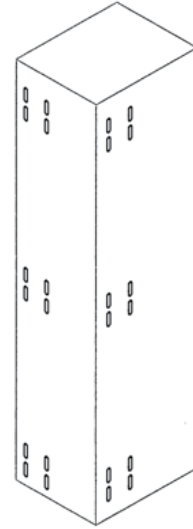

Intermediate Filler

CATALOG NO.	SIZE	WEIGHT
S3-INTER	SPECIFY	96

Filler comes with two sides, a front, and a top cap. Used where double faced units meet single faced units along a wall.

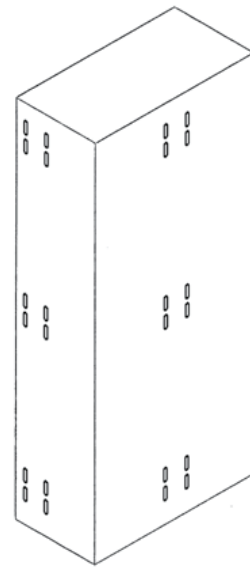

Column Extender

CATALOG NO.	SIZE	WEIGHT
S3-CEXT12	12	4

Used to increase the height of a unit. Splice plate of extender is bolted to the column where the top cross bar was located. Top cross bar is then re-attached at the top of the extender. Wall anchors are not included.



System 30®

Findable Book Support

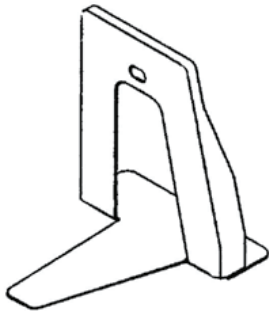

CATALOG NO.	SIZE	WEIGHT
S3-FIND6	6	1
S3-FIND9	9	1½

Cork available on above.
Add the letter C to the end of the catalog number.
May be used on flat or integral back shelves.

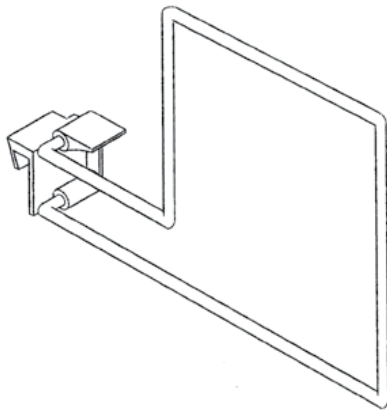

Sliding Wire Book Support

CATALOG NO.	SIZE	WEIGHT
S3-SBS6	6 x 6¾	½
S3-SBS8	6 x 8¾	½

Used on Integral Back Shelves.

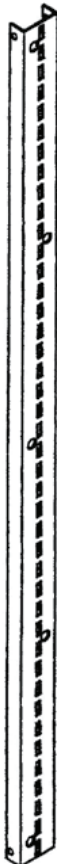

Wall Column Strips

CATALOG NO.	SIZE	WEIGHT
S3-COL42	1¾ x 42	3
S3-COL60	1¾ x 60	5
S3-COL66	1¾ x 66	5½
S3-COL72	1¾ x 72	6
S3-COL78	1¾ x 78	6½
S3-COL84	1¾ x 84	7
S3-COL90	1¾ x 90	8

Two column strips are used for each starter section and one for each adder section. Ideal for areas above desks or where baseboard heating interferes with placing a closed base unit against the wall.

System 30®

Flat End Brackets 3" High

Single Bracket

CATALOG NO.	SIZE	WEIGHT
S3-SFEB09-3	9	3/4
S3-SFEB10-3	10	3/4
S3-SFEB11-3	11	1
S3-SFEB13-3	13	1
S3-SFEB17-3	17	1 1/4

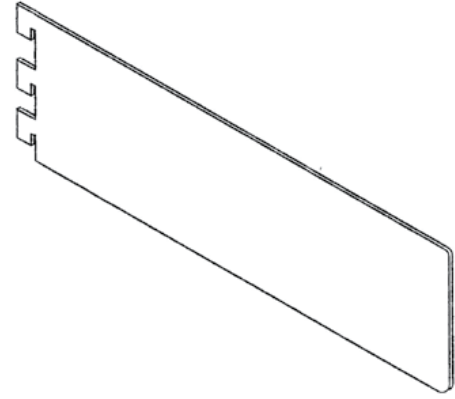

Flat End Brackets 6" High

Single Bracket

CATALOG NO.	SIZE	WEIGHT
S3-SFEB09-6	9	1
S3-SFEB10-6	10	1 1/4
S3-SFEB11-6	11	1 1/4
S3-SFEB13-6	13	1 1/2
S3-SFEB17-6	17	2

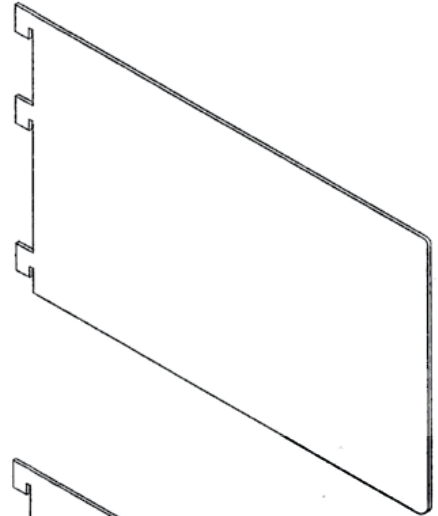

Flat End Brackets 8" High

CATALOG NO.	SIZE	WEIGHT
S3-SFEB09-8	9	1 1/4
S3-SFEB10-8	10	1 1/2
S3-SFEB11-8	11	1 1/2
S3-SFEB13-8	13	1 3/4
S3-SFEB14-8-HP	14	2
S3-SFEB17-8	17	2 1/4

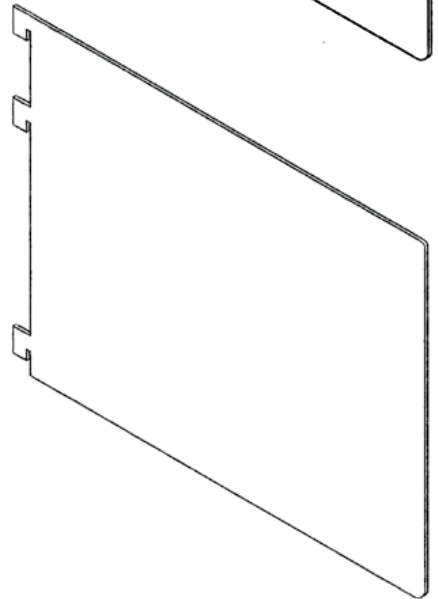

Top Tie Strut

CATALOG NO.	SIZE	WEIGHT
S3-STRUT96	96	6

Fasten with tek screws to cross bar. Tek screws not included.

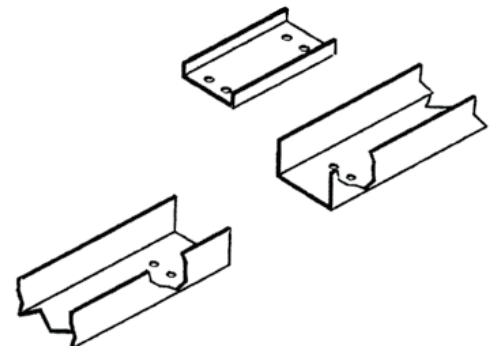

System 30®

Terms and Conditions

PRICES

All prices printed herein supersede all previous prices and are subject to change without notice. These prices are F.O.B. origin, Aurora, Illinois, exclude freight and are subject to an additional charge for special color, special packaging, states' sales or consumer taxes as required. One order constitutes one color with only one delivery address.

SALES POLICY

Possession of this price list does not constitute authority to purchase and/or sell products contained within. Aurora Storage Products has the right to refuse any purchase order.

GLOSS-TEK COLORS AND WOOD-TEK

Aurora Storage Products are coated in Gloss-Tek™ an eco-friendly, non-emissive textured powder coat. There are 31 standard colors; custom colors are available and are subject to longer lead time and an additional charge. A metal color chip of the special color is necessary for paint matching.

NOTE: Even with metal sample matching, shading and gloss can vary. Be careful when matching new equipment to product of the same color that has been in the field for several years. Products closely exposed to fluorescent lighting or sunlight can fade. If a perfect match is required, forward a sample to Customer Service.

WOOD-TEK PRODUCT

Orders of non-standard Wood-Tek stain and wood species require a stain match and approval. Special caution must be given to matching new product to product which has been in the field for several years. Product exposed to sunlight or fluorescent lighting can fade or darken. Aurora Storage Products will not guarantee or be responsible for the character of wood including natural variations in color, grain, and texture, and may differ slightly from sample.

TERMS OF PAYMENT

Net 30 days from date of invoice. We accept Visa and Master Card.

WEIGHTS

Weights are not intended to be used for structural load bearing calculations. Shipping weights can be obtained from Quik-Quote or by consulting Aurora Customer Service.

SPECIFICATIONS

Subject to change without notice.

DISCONTINUED ITEMS

We reserve the right, without notice, to discontinue the manufacture and sale of any items printed herein.

FREIGHT POLICY

Aurora Storage Products offers multiple freight options. Aurora Storage Products ship as Class 70, F.O.B., Aurora, IL 60506. Other freight options include:

- Third Party, F.O.B. point of destination
- Collect, F.O.B. point of destination
- Prepaid and add, F.O.B. point of origin
- UPS shipments will ship prepaid and add actual cost.
- PRIME Program (Positive Rate Information and Management Equalizer) is a very competitive freight program that allows Aurora Storage Products to pass full freight discounts directly to all Authorized Aurora Product Dealers.

Normal delivery is dock-to-dock. Special requests such as inside delivery, lift gate service, residential delivery, etc. are subject to additional charges. All accessorial changes not requested on purchase order will be the responsibility of the consignee.

Delivery date and time are at the discretion of the carrier within reasonable transit time unless special arrangements have been made between the customer and Aurora Storage Products.

Customer routed shipments and pick-ups must be picked up from Aurora Storage Products within 48 hours of notification that the shipment is ready or Aurora Storage Products will ship prepaid and add.

TITLE TO MERCHANDISE

Title to merchandise shall pass to the buyer upon delivery by Aurora Storage Products to the carrier on FOB Factory. Buyer acknowledges that once Aurora Storage Products delivers goods to the carrier, title to the goods and risk of loss will pass to the buyer. If the goods are damaged by the carrier while in transit, the buyer has the sole obligation of seeking recourse from the carrier. If the goods are lost by the carrier, buyer may at their option either:

- 1) File a freight claim with carrier.
- 2) Place a new purchase order with Aurora Storage Products.

ORDER CHANGES

Any changes to an order after 5 days of the date of the first order acknowledgement are subject to a change order fee of \$100 for every change.

At the discretion of Aurora Storage Products any changes to orders after receipt of an order acknowledgement are assigned a new delivery date regardless of the lead time quoted.

CANCELLATION CHARGES

If customer cancels an order after 5 days of the date of the first order acknowledgement, customer shall be subject to a charge of 20% percent of the net amount of the order.

SPECIAL ITEM CHANGES OR CANCELLATIONS

Non-standard, specially designed product, or purchased items such as Quik-Roll™ or laminates may not be changed, cancelled, or returned for credit. Aurora Storage Products reserves the right to determine what products are special.

DAMAGE IN TRANSIT

CAUTION: When you give the delivering carrier a clear receipt for a shipment in which there is damaged merchandise or a shortage, the carrier and Aurora Storage Products are relieved of further responsibility.

All packaging is in accordance with carrier requirements.

For your protection, before accepting any shipment, examine it carefully. If there is evidence of damage or a shortage, insist that the delivering carrier make suitable notation to that effect on the freight bill before you sign it.

If, after receipt of shipment, concealed damage is discovered, immediately **notify the delivering carrier**, requesting immediate inspection. The inspection report should be used to support your claim against the carrier. *NOTE:* Carriers require notification of concealed damage within 24 hours of delivery. Aurora Storage Products also needs to be notified of any concealed damage claims.

Any claim for damage or shortage on non-PRIME carrier shipments must be noted by you with the non-PRIME delivering carrier. Aurora Storage Products will not accept the return of merchandise damaged in transit. Your recourse is with the delivering carrier. Freight claim filing is the responsibility of the consignee and not Aurora Storage Products unless a PRIME carrier is used for the shipment.

SHIPMENT SHORTAGE CLAIMS

Shortage claims reported after 15 days beyond the shipment date will not be honored.

RETURN GOODS POLICY

1. Requests in writing for Return Goods Authorization must be made to the Aurora Storage Products Customer Service Department within 21 days of the shipment from Aurora Storage Products.
2. Aurora Storage Products will determine the eligibility to return any material and will notify the requester within 5 days upon receipt of written request. Aurora Storage Products will also instruct the requester to return the material to Aurora Storage Products or dispose of such before the issuance of the appropriate credit.
3. Special items and items not manufactured by Aurora Storage Products (purchased) will not be eligible for return.
4. Any material returned to Aurora Storage Products or disposed of without the proper authorization by Aurora Storage Products will be refused and no credit will be issued.
5. Returned goods must be shipped freight prepaid at the requester's expense within 30 days of receipt of written authorization. The requester must determine the carrier. If the RGA is due to a Aurora Storage Products error, freight can ship collect via PRIME carrier.
6. All material returned must be received in original packaging. Credit will be given on returned resalable material, only after receipt and inspection by Aurora Storage Products. All returned material must be accompanied by the Return Goods Authorization form. Credit for authorized returns are subject to a 25% restocking charge on the net acceptable material value.
7. Total value of returned material must exceed \$200.00 net.

SPECIAL PACKAGING

All material will be shipped in standard pack quantities unless otherwise specified on the purchase order. Where special requests are made for packaging that differs from the standard pack containment, customer bears full responsibility for the cost of such packaging as well as the condition of the product. Aurora Storage Products shall in no way be held responsible for improper packaging or damage in transit.

Aurora Storage Products reserves the right to change or modify packaging or package quantities without notice.

If customer requests that skidding be utilized, the customer shall bear the cost of the skids. At times it may be necessary to consider special crating. Consult the factory for crating charges.

PRODUCT ASSEMBLY

Aurora Storage Products are shipped "KD" (unassembled) and assembly is required at the job site. Consult appropriate installation manual.

WELDED FRAME 1000 SERIES



 **Material Handling USA**

**Call Now for a Free
Quote or Site Visit!**

222 S. Main St. 5th Floor
Salt Lake City, UT 84101
800-326-4403
<https://www.mh-usa.com/>

Material Handling USA

SUPERSTORE

MH-USA



The Aurora MJ Advantages

- True unit construction. Each unit is completely independent of the next.
 - Welded frame eliminates the need for unsightly sway braces. Allows clear filing from one side to the other for oversized volumes.
 - Lower installation cost.
 - One piece base shelf and base brackets.
 - Canopy top accepts wire book supports.
 - Accessories and components can be easily mixed and matched on any section.
 - All fasteners are concealed within the design.
 - Our state-of-the-art powder coat paint system gives us the most durable paint finish in the industry. We offer fifteen standard colors. Special colors can be matched to please even the most discriminating eye.
 - On time delivery. Most deliveries can be made in six to eight weeks after receipt of an order. When we make a commitment we keep it.
 - Quality that is second to none.
 - We can manufacture most special items to include special heights, widths, and specialty products in minimal lead times and at a reasonable cost.
 - MJ Library has been associated with the metal fabricating industry for over forty years with over twenty years of library experience.
 - We have a nationwide sales organization which is fully trained to assist you with your library planning.
- Contact Material Handling USA Products at 800-326-4403 for the name of your local dealer.**

CHANGING THE STORY:

In the time of COVID-19, Aurora Storage is more committed to advising and meeting your safety needs than ever. Rest easy knowing we have a solution for every story.

Shelf Selection

TYPE OF VOLUMES	NO. OF VOLS. PER LINEAR FOOT OF SHELF	RECOMMENDED DEPTH OF SHELF
Circulation (Non-Fiction)	8	9-10 in.
Fiction	8	8-9 in.
General Literature	7	9-10 in.
Economics	8	9-10 in.
Reference	6	9-10-12 in.
History	7	9-10 in.
Technical & Scientific	6	10-12 in.
Law	5	10 in.
Medical	5	9-10-12 in.
Bound Periodicals	5	10-12 in.
Art (Folios)	7	10-12 in.
Juvenile (Elementary)	10	9-10 in.
Juvenile (Pre-School)	12	10-12 in.
Public Documents	5	9-10 in.

Nominal vs. Actual Dimensions

For Cantilever-type Bookstack, the adjustable shelves and base shelf depths are given in “nominal” dimensions, which indicates the depth from the front edge of the shelf to the centerline of the 2” depth frame.

For adjustable shelves, the actual depth is 1” less than the “nominal” depth.

For base shelves, the actual depth of the shelf, as well as the overall depth of the bookstack unit, will measure 1-3/8” greater than the “nominal” depth for single-faced units, and 7/16” greater than the “nominal” depth for double-faced units.

All heights indicated for Bookstack Units are actual heights.





66" high unit shown above.

NOTE: All single faced units must be anchored to the wall. Units come standard 36" wide. 30" and 24" wide units are also available at the same price. When ordering 30" wide change catalog number to begin with MJ30 instead of MJ36. Special widths and heights are also available. Contact factory for pricing.

Closed Base Bookstack Shelving Single Faced

42" High 2 Adjustable Shelves 1 Base Shelf

CATALOG NO.	SHELF DEPTH	BASE DEPTH	WGT. LBS.
MJ36080842	8"	8"	41
MJ36081042	8"	10"	43
MJ36090942	9"	9"	44
MJ36091042	9"	10"	45
MJ36101042	10"	10"	46
MJ36101242	10"	12"	47
MJ36121242	12"	12"	51

66" High 4 Adjustable Shelves 1 Base Shelf

CATALOG NO.	SHELF DEPTH	BASE DEPTH	WGT. LBS.
MJ36080866	8"	8"	58
MJ36081066	8"	10"	60
MJ36090966	9"	9"	62
MJ36091066	9"	10"	63
MJ36101066	10"	10"	65
MJ36101266	10"	12"	67
MJ36121266	12"	12"	74

78" High 5 Adjustable Shelves 1 Base Shelf

CATALOG NO.	SHELF DEPTH	BASE DEPTH	WGT. LBS.
MJ36080878	8"	8"	66
MJ36081078	8"	10"	68
MJ36090978	9"	9"	71
MJ36091078	9"	10"	72
MJ36101078	10"	10"	75
MJ36101278	10"	12"	77
MJ36121278	12"	12"	86

84" High 6 Adjustable Shelves 1 Base Shelf

CATALOG NO.	SHELF DEPTH	BASE DEPTH	WGT. LBS.
MJ36080884	8"	8"	74
MJ36081084	8"	10"	76
MJ36090984	9"	9"	79
MJ36091084	9"	10"	80
MJ36101084	10"	10"	83
MJ36101284	10"	12"	85
MJ36121284	12"	12"	96

90" High 6 Adjustable Shelves 1 Base Shelf

CATALOG NO.	SHELF DEPTH	BASE DEPTH	WGT. LBS.
MJ36080890	8"	8"	75
MJ36081090	8"	10"	77
MJ36090990	9"	9"	81
MJ36091090	9"	10"	82
MJ36101090	10"	10"	85
MJ36101290	10"	12"	86
MJ36121290	12"	12"	98

Double Faced

42" High 4 Adjustable Shelves 1 Base Shelf

CATALOG NO.	SHELF DEPTH	BASE DEPTH	WGT. LBS.
MJ36081642	8"	16"	60
MJ36082042	8"	20"	64
MJ36091842	9"	18"	65
MJ36092042	9"	20"	67
MJ36102042	10"	20"	69
MJ36102442	10"	24"	72
MJ36122442	12"	24"	80

66" High 8 Adjustable Shelves 1 Base Shelf

CATALOG NO.	SHELF DEPTH	BASE DEPTH	WGT. LBS.
MJ36081666	8"	16"	89
MJ36082066	8"	20"	93
MJ36091866	9"	18"	97
MJ36092066	9"	20"	99
MJ36102066	10"	20"	104
MJ36102466	10"	24"	107
MJ36122466	12"	24"	122

78" High 10 Adjustable Shelves 1 Base Shelf

CATALOG NO.	SHELF DEPTH	BASE DEPTH	WGT. LBS.
MJ36081678*	8"	16"	104
MJ36082078	8"	20"	108
MJ36091878*	9"	18"	114
MJ36092078	9"	20"	116
MJ36102078*	10"	20"	121
MJ36102478	10"	24"	124
MJ36122478	12"	24"	143

84" High 12 Adjustable Shelves 1 Base Shelf

CATALOG NO.	SHELF DEPTH	BASE DEPTH	WGT. LBS.
MJ36081684*	8"	16"	117
MJ36082084	8"	20"	121
MJ36091884*	9"	18"	129
MJ36092084	9"	20"	131
MJ36102084*	10"	20"	137
MJ36102484	10"	24"	140
MJ36122484	12"	24"	163

90" High 12 Adjustable Shelves 1 Base Shelf

CATALOG NO.	SHELF DEPTH	BASE DEPTH	WGT. LBS.
MJ36081690*	8"	16"	119
MJ36082090	8"	20"	122
MJ36091890*	9"	18"	130
MJ36092090	9"	20"	132
MJ36102090*	10"	20"	138
MJ36102490	10"	24"	141
MJ36122490	12"	24"	164



66" high unit shown above.

*NOTE: Units with an asterisk after the catalog number must be anchored to the floor or with a top tie strut. Units come standard 36" wide. 30" and 24" wide units are also available at the same price. When ordering 30" wide change catalog number to begin with MJ30 instead of MJ36. Special widths and heights are also available. Contact factory for pricing.



66" high unit shown above.

NOTE: All single faced units must be anchored to the wall. Shelves are slotted on 1" centers for dividers and have a 5" high back. Shelves come standard with five dividers per shelf.

Divider Type Sections

Single Faced

42" High

2 Adjustable Divider Shelves 1 Base Shelf

CATALOG NO.	SHELF DEPTH	BASE DEPTH	WGT. LBS.
MJD36101042	10"	10"	60
MJD36101242	10"	12"	62
MJD36121242	12"	12"	66
MJD36141642	14"	16"	74

66" High

4 Adjustable Divider Shelves 1 Base Shelf

CATALOG NO.	SHELF DEPTH	BASE DEPTH	WGT. LBS.
MJD36101066	10"	10"	92
MJD36101266	10"	12"	94
MJD36121266	12"	12"	101
MJD36141666	14"	16"	114

78" High

5 Adjustable Divider Shelves 1 Base Shelf

CATALOG NO.	SHELF DEPTH	BASE DEPTH	WGT. LBS.
MJD36101078	10"	10"	108
MJD36101278	10"	12"	111
MJD36121278	12"	12"	119
MJD36141678	14"	16"	131

90" High

6 Adjustable Divider Shelves 1 Base Shelf

CATALOG NO.	SHELF DEPTH	BASE DEPTH	WGT. LBS.
MJD36101090	10"	10"	123
MJD36101290	10"	12"	126
MJD36121290	12"	12"	136
MJD36141690	14"	16"	154

93" High

7 Adjustable Divider Shelves 1 Base Shelf

CATALOG NO.	SHELF DEPTH	BASE DEPTH	WGT. LBS.
MJD36101093	10"	10"	137
MJD36101293	10"	12"	140
MJD36121293	12"	12"	152
MJD36141693	14"	16"	172

Double Faced

42" High

4 Adjustable Divider Shelves 2 Base Shelves

CATALOG NO.	SHELF DEPTH	BASE DEPTH	WGT. LBS.
MJD36102042	10"	20"	104
MJD36102442	10"	24"	109
MJD36122442	12"	24"	116
MJD36143242	14"	32"	133

66" High

8 Adjustable Divider Shelves 2 Base Shelves

CATALOG NO.	SHELF DEPTH	BASE DEPTH	WGT. LBS.
MJD36102066	10"	20"	161
MJD36102466	10"	24"	165
MJD36122466	12"	24"	179
MJD36143266	14"	32"	206

78" High

10 Adjustable Divider Shelves 2 Base Shelves

CATALOG NO.	SHELF DEPTH	BASE DEPTH	WGT. LBS.
MJD36102078	10"	20"	188
MJD36102478	10"	24"	193
MJD36122478	12"	24"	210
MJD36143278	14"	32"	244

90" High

12 Adjustable Divider Shelves 2 Base Shelves

CATALOG NO.	SHELF DEPTH	BASE DEPTH	WGT. LBS.
MJD36102090	10"	20"	220
MJD36102490	10"	24"	224
MJD36122490	12"	24"	245
MJD36143290	14"	32"	281

93" High

14 Adjustable Divider Shelves 2 Base Shelves

CATALOG NO.	SHELF DEPTH	BASE DEPTH	WGT. LBS.
MJD36102093	10"	20"	248
MJD36102493	10"	24"	252
MJD36122493	12"	24"	276
MJD36143293	14"	32"	316



66" high unit shown above.

NOTE: All double faced units 78" and over must be anchored to the floor or with a top tie strut.



Display Units

Fixed Periodical

Single Faced

CATALOG NO.	NO. SLOPE SHELVES	NO. STORAGE SHELVES	HEIGHT	WGT. LBS.
MJF36121242	2	1	42"	59
MJF36121266	3	2	66"	82
MJF36121278	4	3	78"	102
MJF36121290	5	4	90"	122

Double Faced

CATALOG NO.	NO. SLOPE SHELVES	NO. STORAGE SHELVES	HEIGHT	WGT. LBS.
MJF36122442	4	2	42"	96
MJF36122466	6	4	66"	137
MJF36122478	8	6	78"	175
MJF36122490	10	8	90"	213

NOTE: Display surface is 11" high.

66" high unit shown at left.



Hinged Periodical

Single Faced

CATALOG NO.	NO. SLOPE SHELVES	NO. STORAGE SHELVES	HEIGHT	WGT. LBS.
MJH36121242	2	1	42"	59
MJH36121266	4	3	66"	100
MJH36121278	5	4	78"	120
MJH36121290	6	5	90"	140

Double Faced

CATALOG NO.	NO. SLOPE SHELVES	NO. STORAGE SHELVES	HEIGHT	WGT. LBS.
MJH36122442	4	2	42"	96
MJH36122466	8	6	66"	173
MJH36122478	10	8	78"	211
MJH36122490	12	10	90"	249

NOTE: Display Surface is 14" high.

66" high unit shown at left.

Sloped Display Unit

Single Faced

CATALOG NO.	SHELF DEPTH	BASE DEPTH	HEIGHT	WGT. LBS.
MJS36081566	8 ¹ / ₀	15 ³ / ₄	66"	104
MJS36081584	8 ¹ / ₀	15 ³ / ₄	84"	138

84" high unit comes with seven shelves per face.



66" high unit shown at right.

Sloped Display Unit

Double Faced

CATALOG NO.	SHELF DEPTH	BASE DEPTH	HEIGHT	WGT. LBS.
MJS36082866	8 ¹ / ₀	28 ¹ / ₂	66"	184
MJS36082884	8 ¹ / ₀	28 ¹ / ₂	84"	240

Bottom shelf is 8" nominal.
All other shelves are 10" nominal.
Unit comes standard with flush backs.

84" high unit comes with seven shelves per face.



66" high unit shown at right.



Accessories

Book Supports

Findable Book Supports

CATALOG NO.	HEIGHT	WGT. LBS.
MJFIND6	6"	1
MJFIND9	9"	1½

Cork available on above.

Hook-On Book Support

CATALOG NO.	HEIGHT	WGT. LBS.
MJHOOK6	6"	1
MJHOOK9	9"	1½

Cork available on above.

Wire Book Support

CATALOG NO.	SHELF DEPTH	WGT. LBS.
MJWIRE9	Fits 8" or 9"	¼
MJWIRE12	Fits 10" or 12"	¼

Attaches to underside of shelf or canopy top.



Sliding Wire Book Support

CATALOG NO.	SHELF DEPTH	WGT. LBS.
S3SBS6	Fits 8" or 9"	½
S3SBS8	Fits 10" or 12"	½

Attaches to back edge of integral back shelf.



Slotted Track Book Supports

CATALOG NO.	HEIGHT	WGT. LBS.
MJSLOTBS6	6"	1
MJSLOTBS9	9"	1½

Used with slotted track shelf only.





Accessories

Plastic Shelf Label Holder

CATALOG NO.	SIZE	WGT. LBS.
MJLABEL5	5" W x 3/4" H	1/8



Brackets for Wood Tops

CATALOG NO.	SIZE	WGT. LBS.
MJWOODBKT8	8"	1

Used for attaching wood or laminate tops.
Use two pair for double faced units.



Range Finder

CATALOG NO.	SIZE	WGT. LBS.
MJRANGE35	5 1/2" W x 3 1/2" H	1/2
PLASTIC CARD	5" W x 3" H	1/8

Used on end panels or uprights. Furnished in painted steel.



Card Holders

Zinc Plated

CATALOG NO.	SIZE	WGT. LBS.
MJZINC35	5 1/2" W x 3 1/2" H	1/4

Painted Steel

CATALOG NO.	SIZE	WGT. LBS.
MJPAINT35	5 1/2" W x 3 1/2" H	1/4
PLASTIC CARD	5" W x 3" H	

NOTE: Attaches to end panels with double sided tape.

Intermediate Filler

CATALOG NO.	SIZE	WGT. LBS.
MJINTER	Specify	136

Used to fill void created when two single faced sections are joined at a right angle with a double faced unit.

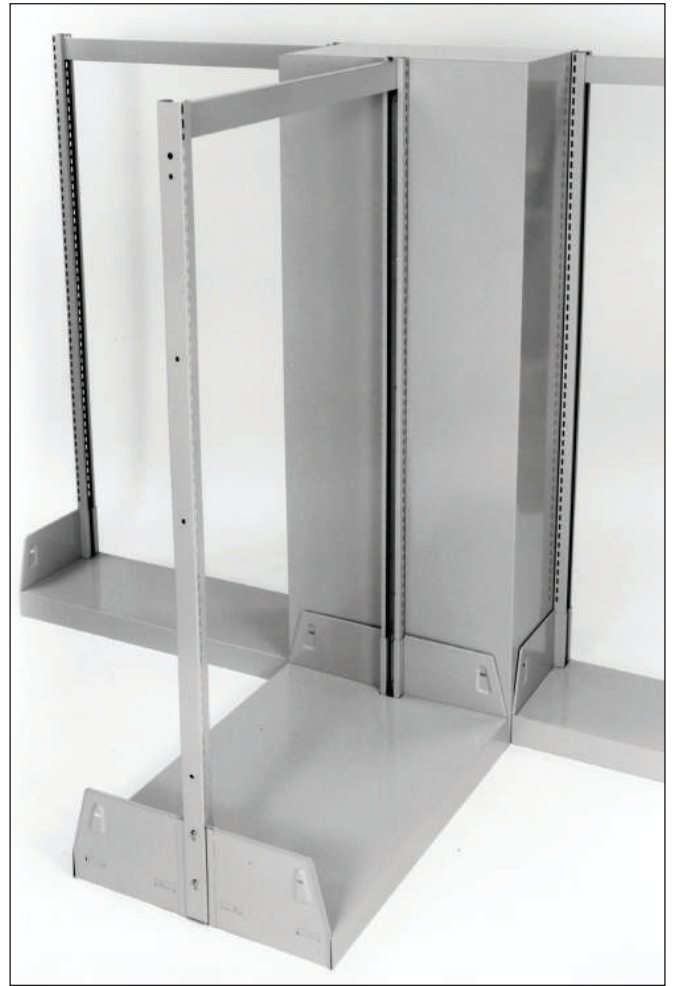

Corner Filler

CATALOG NO.	SIZE	WGT. LBS.
MJCORNER	Specify	78

Used to fill void created when two sections meet at right angles to each other. Available in all heights and depths.





Accessories

Metal End Panels

Single Faced

CATALOG NO.	SIZE	WGT. LBS.
MJEND0842	8" x 42"	11
MJEND0942	9" x 42"	12
MJEND1042	10" x 42"	13
MJEND1242	12" x 42"	14
MJEND1642S	16" x 42"	16
MJEND0866	8" x 66"	17
MJEND0966	9" x 66"	18
MJEND1066	10" x 66"	19
MJEND1266	12" x 66"	20
MJEND1666S	16" x 66"	24
MJEND0878	8" x 78"	19
MJEND0978	9" x 78"	20
MJEND1078	10" x 78"	21
MJEND1278	12" x 78"	24
MJEND1678S	16" x 78"	28
MJEND0884	8" x 84"	21
MJEND0984	9" x 84"	22
MJEND1084	10" x 84"	23
MJEND1284	12" x 84"	25
MJEND1684S	16" x 84"	31
MJEND0890	8" x 90"	22
MJEND0990	9" x 90"	23
MJEND1090	10" x 90"	24
MJEND1290	12" x 90"	27
MJEND1690S	16" x 90"	33
MJEND0893	8" x 93"	23
MJEND0993	9" x 93"	24
MJEND1093	10" x 93"	25
MJEND1293	12" x 93"	28
MJEND1693S	16" x 93"	34

Metal End Panels

Double Faced

CATALOG NO.	SIZE	WGT. LBS.
MJEND1642	16" x 42"	19
MJEND1842	18" x 42"	20
MJEND2042	20" x 42"	21
MJEND2442	24" x 42"	24
MJEND3242	32" x 42"	30
MJEND1666	16" x 66"	29
MJEND1866	18" x 66"	31
MJEND2066	20" x 66"	33
MJEND2466	24" x 66"	37
MJEND3266	32" x 66"	45
MJEND1678	16" x 78"	34
MJEND1878	18" x 78"	36
MJEND2078	20" x 78"	39
MJEND2478	24" x 78"	44
MJEND3278	32" x 78"	53
MJEND1684	16" x 84"	36
MJEND1884	18" x 84"	39
MJEND2084	20" x 84"	42
MJEND2484	24" x 84"	47
MJEND3284	32" x 84"	57
MJEND1690	16" x 90"	39
MJEND1890	18" x 90"	42
MJEND2090	20" x 90"	44
MJEND2490	24" x 90"	50
MJEND3290	32" x 90"	61
MJEND1693	16" x 93"	41
MJEND1893	18" x 93"	43
MJEND2093	20" x 93"	46
MJEND2493	24" x 93"	52
MJEND3293	32" x 93"	63



NOTE: Size of end panels must match the depth of the base shelf and the canopy top.

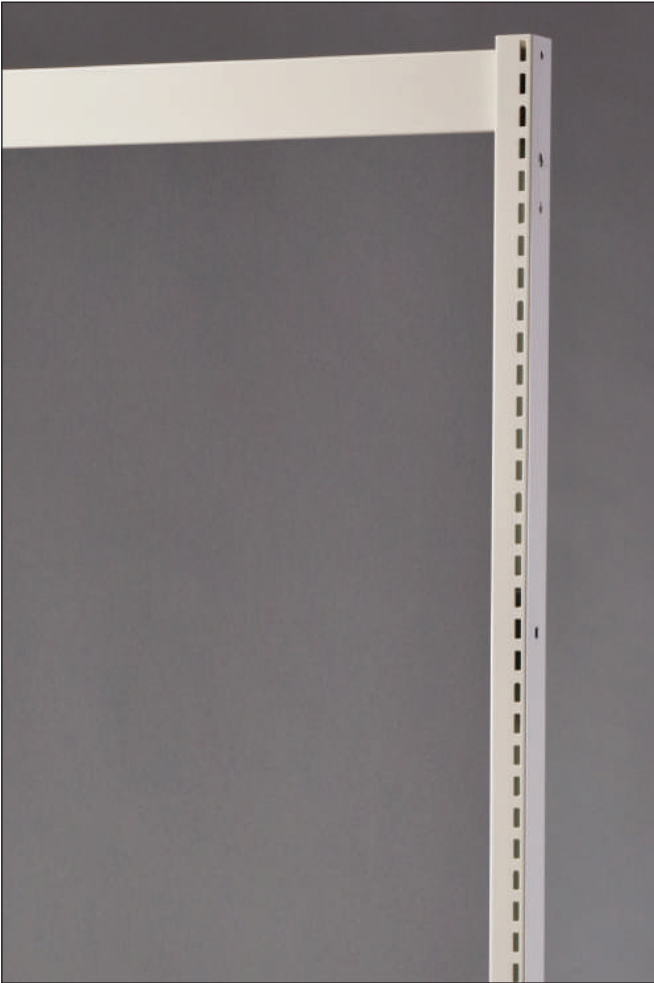

Components

Standard Welded Frames

CATALOG NO.	HEIGHT	WGT. LBS.
MJFRAME3642	42"	16
MJFRAME3666	66"	19
MJFRAME3678	78"	22
MJFRAME3684	84"	23
MJFRAME3690	90"	24
MJFRAME3693	93"	25

All frames are 36" wide.

30" wide are also available at the same price.

Change catalog number to begin with MJFRAME30 instead of MJFRAME36.



Seismic Welded Frames

CATALOG NO.	HEIGHT	WGT. LBS.
MJFRAME3678S	78"	40
MJFRAME3684S	84"	41
MJFRAME3690S	90"	42

Eliminates the need for sway braces.

NOTE: Triangular gussets sold separately.

Triangular Gussets

Single Faced – Specify LH. or RH.

CATALOG NO.	BASE DEPTH	WGT. LBS.
MJGUS3608	8"	5
MJGUS3609	9"	6
MJGUS3610	10"	7
MJGUS3612	12"	8



Triangular Gussets

Double Faced

CATALOG NO.	BASE DEPTH	WGT. LBS.
MJGUS3616	16"	10
MJGUS3618	18"	12
MJGUS3620	20"	13
MJGUS3624	24"	16
MJGUS3632	32"	21

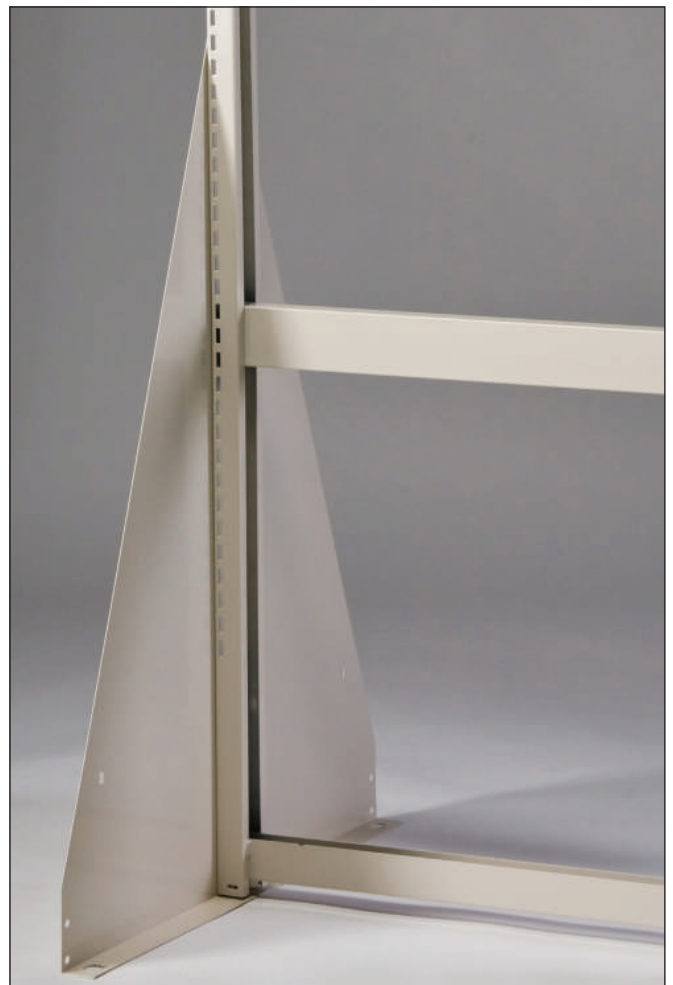



Components

Closed Base Shelves

Single Faced

CATALOG NO.	BASE DEPTH	WGT. LBS.
MJBASE3608	8"	13
MJBASE3609	9"	14
MJBASE3610	10"	15
MJBASE3612	12"	17
MJBASE3616S	16"	20

Double Faced

CATALOG NO.	BASE DEPTH	WGT. LBS.
MJBASE3616	16"	20
MJBASE3618	18"	22
MJBASE3620	20"	24
MJBASE3624	24"	27
MJBASE3632	32"	33

Comes complete with base brackets.

Integral Back Base Shelves

Single Faced

CATALOG NO.	BASE DEPTH	WGT. LBS.
MJBASE3608INT	8"	11
MJBASE3609INT	9"	12
MJBASE3610INT	10"	13
MJBASE3612INT	12"	15

Double Faced

CATALOG NO.	BASE DEPTH	WGT. LBS.
MJBASE3616INT	16"	19
MJBASE3618INT	18"	20
MJBASE3620INT	20"	22
MJBASE3624INT	24"	25

NOTE: Base shelf is formed with an upturned flange.
Double faced base is two piece.

Divider Base Shelves

Single Faced

CATALOG NO.	BASE DEPTH	WGT. LBS.
MJBASE3610DIV	10"	17
MJBASE3612DIV	12"	20
MJBASE3616DIV	16"	24



Double Faced

CATALOG NO.	BASE DEPTH	WGT. LBS.
MJBASE3620DIV	20"	32
MJBASE3624DIV	24"	37
MJBASE3632DIV	32"	45

Comes complete with base brackets and five 6" high dividers. Base is slotted on 1" centers and has a 5" high back.

NOTE: Standard base is 3" high. 4" high bases can also be furnished. Contact factory for pricing.



Sloping Base Shelves

Single Faced

CATALOG NO.	BASE DEPTH	WGT. LBS.
MJBASE3608SLOPE	8"	14
MJBASE3609SLOPE	9"	15
MJBASE3610SLOPE	10"	16
MJBASE3612SLOPE	12"	18

Double Faced

CATALOG NO.	BASE DEPTH	WGT. LBS.
MJBASE3616 SLOPE	16"	22
MJBASE3618 SLOPE	18"	24
MJBASE3620 SLOPE	20"	26
MJBASE3624 SLOPE	24"	29

Used to display books at an angle.





Components

Adjustable Shelves

CATALOG NO.	SHELF DEPTH	WGT. LBS.
MJAS3608	8"	6
MJAS3609	9"	7
MJAS3610	10"	8
MJAS3612	12"	9
MJAS3616	16"	13

Comes complete with end brackets.



Adjustable Divider Shelves

CATALOG NO.	SHELF DEPTH	WGT. LBS.
MJDIV3610	10"	14
MJDIV3612	12"	16
MJDIV3614	14"	17

Comes complete with end brackets and five 6" high dividers. Shelf is slotted on 1" centers and has a 5" high back.



Integral Back Shelves

CATALOG NO.	SHELF DEPTH	WGT. LBS.
MJINT3608	8"	6
MJINT3609	9"	7
MJINT3610	10"	8
MJINT3612	12"	9

Comes complete with end brackets.



Slotted Track Shelves

CATALOG NO.	SHELF DEPTH	WGT. LBS.
MJSLOT3608	8"	6
MJSLOT3609	9"	7
MJSLOT3610	10"	8
MJSLOT3612	12"	9

Comes complete with end brackets.

Hinged Periodical Shelves with Standard Adjustable Shelf

CATALOG NO.	SIZE	WGT. LBS.
MJHIN3612	36" x 12"	18
MJHIN3616	36" x 16"	22

Display surface is 14" high and lifts up for access to storage of back issues.

Continuous label holders are available.



Hinged Periodical Shelves with Plexiglass Cover

CATALOG NO.	SIZE	WGT. LBS.
MJHIN3612PLEX	36" x 12"	21
MJHIN3616PLEX	36" x 16"	25

Plexiglass covers come in either one or two pieces.

Please specify on order.



Hinged Periodical Shelves with Plexiglass Cover and Divider Shelf

CATALOG NO.	SIZE	WGT. LBS.
MJHIN3612PLEX-D	36" x 12"	27
MJHIN3616PLEX-D	36" x 16"	31

Divider shelf is used to create individual compartments for storage of back issues.

Plexiglass covers come in either one or two pieces.

Please specify on order.





Components

Fixed Periodical Shelf

CATALOG NO.	SIZE	WGT. LBS.
MJFIX3612	36" x 12"	9

Display surface is 11" high.



Storage Shelf

CATALOG NO.	SIZE	WGT. LBS.
MJSTOR3612	36" x 12"	9

Storage shelf is used for storing back issues under the fixed periodical shelf, or whenever flat storage is needed.



Heavy Duty Storage Shelf

CATALOG NO.	SIZE	WGT. LBS.
MJSTOR3618HD	36" x 18"	20



Tip-Up Periodical Cabinet

CATALOG NO.	SIZE	WGT. LBS.
MJPERCAB3617	36" x 17"	38

Ideal for increased storage of back issues.
 Provides up to 12-1/2" of storage height.
 Ideal for storing issues in Princeton type boxes.
 11 boxes will fit on a shelf.



Components

Multi-Media Cabinet

CATALOG NO.	SIZE	WGT. LBS.
MJMM CAB36 Includes lock only.	36" x 16"	53
MJMM CAB36-1 Includes lock and one pull out frame.	36" x 16"	59
MJMM CAB36-2 Includes lock and two pull out frames.	36" x 16"	65

NOTE: Door slides up and out of view for easy access to trays.
Trays must be ordered separately.



Cabinet Storage Trays

CATALOG NO.	SIZE	WGT. LBS.
MJCASSETTE Will hold 18 audio cassettes per tray and 126 per pull out frame.	3" H x 4½" W	3
MJVIDEO Will hold 11 video cassettes per tray and 44 per pull out frame.	3¼" H x 7¼" W	4
MJMICROFILM Will hold 7 microfilm boxes per tray and 56 per pull out frame.	3½" H x 3¾" W	3
MJCD Will hold 29 CDs per tray and 174 per pull out frame.	4½" H x 5¼" W	4
MJMICROFICHE Will hold 905 microfiches per tray and 4525 per pull out frame.	4" H x 6¼" W	4

NOTE: Each tray comes with one divider.





Components

Paperback/CD Shelf

CATALOG NO.	SIZE	WGT. LBS.
MJPB3606	36" x 6"	11

Comes complete with six dividers.
Shelf slopes at 7° angle.



Zig-Zag Display

CATALOG NO.	SIZE	WGT. LBS.
MJZIGZAG36	36" x 4"	3

Price includes Zig-Zag only.
Shelf must be ordered separately.
Attaches to shelf with small angle brackets and double sided tape.



Hang-Up Bag Rack

CATALOG NO.	SIZE	WGT. LBS.
MJBAG3612	36" x 12"	4

Used for hanging bags. Bags not included.



Sliding Reference Shelves

CATALOG NO.	SIZE	WGT. LBS.
MJREF3608	8"	9
MJREF3609	9"	10
MJREF3610	10"	11
MJREF3612	12"	12

Attaches underneath regular shelves.
When used with divider shelves add suffix (DIV) to catalog number.



Dividers

6" High

CATALOG NO.	SHELF DEPTH	SIZE	WGT. LBS.
MJDIV68	10"	6" x 8"	1
MJDIV610	12"	6" x 10"	1
MJDIV612	14"	6" x 12"	1

10" High

CATALOG NO.	SHELF DEPTH	SIZE	WGT. LBS.
MJDIV108	10"	10" x 8"	2
MJDIV1010	12"	10" x 10"	2½
MJDIV1012	14"	10" x 12"	3



Microfilm Shelf

CATALOG NO.	SIZE	WGT. LBS.
MJMICRO3604	36" x 4"	5



Double Tier Shelf

CATALOG NO.	SIZE	WGT. LBS.
MJDT3610	36" x 10"	11

Each tier is 4" deep and 3" high.
A total of 102 cassettes can be stored on each shelf.
Can also be used to store microfilm boxes.





Components

Single Tier Browsing Box

CATALOG NO.	SIZE	WGT. LBS.
MJSTBROWSE3612	36" x 12"	13

Comes complete with five rod dividers.
Can be used for CDs, video tapes and DVDs.

Capacity: 114 - CDs
48 - Video Tapes
78 - DVDs



Single Tier Pull-Out Browsing Box

CATALOG NO.	SIZE	WGT. LBS.
MJSTBROWSE3612PO	36" x 12"	23

Comes complete with five rod dividers.
Can be used for CDs, video tapes and DVDs.

Capacity: 114 - CDs
48 - Video Tapes
78 - DVDs



Double Tier Browsing Box

CATALOG NO.	SIZE	WGT. LBS.
MJDTBROWSE3617	36" x 17"	29

Comes complete with ten rod dividers.
Can be used for CDs, video tapes and DVDs.

Capacity: 144 - CDs
60 - Video Tapes
96 - DVDs



Double Tier Pull-Out Browsing Box

CATALOG NO.	SIZE	WGT. LBS.
MJDTBROWSE3617PO	36" x 17"	44

Comes complete with ten rod dividers.
Can be used for CDs, video tapes and DVDs.

Capacity: 144 - CDs
60 - Video Tapes
96 - DVDs

Center Backstop

CATALOG NO.	HEIGHT	WGT. LBS.
MJBSTOP36CTR	36"	2

Allows full use of shelf space between uprights of welded frame.
Fully adjustable.
One backstop can be used in the middle of shelves on double faced units.
Eliminates the need for one backstop per shelf.



Adjustable Shelf Backstop

CATALOG NO.	WIDTH	WGT. LBS.
MJBSTOP36	36"	2

Fully adjustable, moves up or down independently of shelf end brackets.



Newspaper Rack

CATALOG NO.	SIZE	WGT. LBS.
MJRACK3606	12" D x 14" H	10
MJRACK3610	12" D x 22" H	12
MJSTICK36	36"	1



Closed Backs

CATALOG NO.	HEIGHT	WGT. LBS.
MJBACK3642	42"	21
MJBACK3666	66"	34
MJBACK3678	78"	41
MJBACK3684	84"	44
MJBACK3690	90"	48
MJBACK3693	93"	49

NOTE: Flush backs which completely fill the space between the uprights can also be furnished at twice the price of the regular backs.





Components

Canopy Tops

Single Faced

CATALOG NO.	BASE DEPTH	WGT. LBS.
MJTOP3608	8"	7
MJTOP3609	9"	8
MJTOP3610	10"	9
MJTOP3612	12"	10
MJTOP3616S	16"	13



Double Faced

CATALOG NO.	BASE DEPTH	WGT. LBS.
MJTOP3616	16"	14
MJTOP3618	18"	15
MJTOP3620	20"	16
MJTOP3624	24"	18
MJTOP3632	32"	24

NOTE: Depth of canopy top must match depth of base shelf.
 If top is to be used with column strips add suffix (CS) to the catalog number.
 High pressure laminate or wood tops can also be furnished.
 Contact factory for pricing.



Work Shelf and Brackets

CATALOG NO.	SIZE	WGT. LBS.
MJWORK3624	36" x 24"	25
Includes brackets and plastic laminate work surface.		
MJWORK17BKT	24"	5
Brackets only, price per pair.		

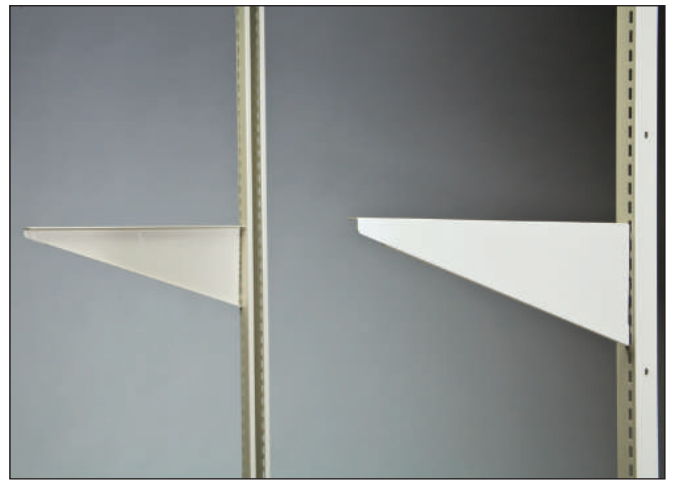

Top Tie Strut

CATALOG NO.	SIZE	WGT. LBS.
MJSTRUT96	96"	5
Used to stabilize non-free standing sections.		



Column Strips

CATALOG NO.	HEIGHT	WGT. LBS.
MJCOL42	42"	2
MJCOL66	66"	4
MJCOL78	78"	5
MJCOL84	84"	5
MJCOL90	90"	6

NOTE: Accepts all MJ components.
Use two column strips for each starter section and one for each additional unit. Hardware for fastening to wall not included.



Movable Concealed Caster Units



Our unit base design completely conceals the casters giving a finished look to a movable cart.



Casters glide smoothly on all types of floors and provide versatility for changing program spaces.

Product Details

MJ System 30 Library Shelving with Concealed Casters provides maximum flexibility through mobility in all library spaces with the vision of designer style shelving solutions.

Concealed casters allow you flexibility to easily move your shelving ranges for many different activities from program spaces, story time settings or simply creating reading/study nooks.

These concealed casters are completely hidden from view and are slim but strong, can swivel 360 degrees and will withstand a fully loaded book stack. Using this 2" caster allows you all the flexibility and the freedom to use custom end panels with no interruptions creating a look of static shelving concealing the caster itself. This streamline look will keep the function of the mobile aspect a well hidden secret.

Standard System 30 product is available with full range of unique storage and accessory components letting you customize your display to suit your demands and offer simple modifications down the road as your needs grow and change.

Features

- Starter and Add-on Units up to 3 Sections Long
- Units heights 42" - 72"
- Custom heights available
- Steel or Custom End Panels and Tops
- Accepts Fully Loaded Book Stack

MJCC-11112019

CHANGING THE STORY:

As you adapt to new safety guidelines, we've built a system that adapts with you. Our concealed caster units move easily to accommodate social distancing.

Curved Shelving



Introducing Curved Shelving
units by Aurora MJ Library.



 **Material Handling USA**
800-326-4403
<https://www.mh-usa.com/>



Aurora's MJ System 30 cantilever library shelving serves as the basis for our new curved shelving.

Curved shelving can be used to create an information pod or by adding MJ's new concealed casters you can create a mobile aspect to display media or create a work station.

Curved shelving is a great way of fashioning an architectural design element to your library. By creating multiple design patterns such as an S design, C shape or letting your imagination run wild you are able to craft a unique space for your library.

Most of our standard System 30 components can be adapted to the curved shelving letting you customize your shelving to suit your demands and offer simple modifications down the road as your needs grow and change.

Contact Aurora Storage Products for complete details and information on our new curved shelving.

MJ LIBRARY SHELVING BY

 **Material Handling USA**
800-326-4403
<https://www.mh-usa.com/>

 **Material Handling USA**

**Call Now for a Free
Quote or Site Visit!**

222 S. Main St. 5th Floor
Salt Lake City, UT 84101
800-326-4403
<https://www.mh-usa.com/>

Material Handling USA

SUPERSTORE

MH-USA

Media Display Shelving



MJ LIBRARY SHELIVING BY

 **Material Handling USA**
800-326-4403
<https://www.mh-usa.com/>

Single Faced Base

44½" High x 8¼" Deep

Basic body only. Shelves sold separately.

CATALOG NUMBER	WIDTH	WEIGHT LBS.
MDBODY390844-S	39-1/2"	64#
MDBODY390844-A	39-1/2"	54#

55½" High x 10⅛" Deep

Basic body only. Shelves sold separately.

CATALOG NUMBER	WIDTH	WEIGHT LBS.
MDBODY391055-S	39-1/2"	85#
MDBODY391055-A	39-1/2"	71#

67½" High x 12" Deep

Basic body only. Shelves sold separately.

CATALOG NUMBER	WIDTH	WEIGHT LBS.
MDBODY391267-S	39-1/2"	102#
MDBODY391267-A	39-1/2"	86#



Double Faced Base

44½" High x 16½" Deep

Basic body only. Shelves sold separately.

CATALOG NUMBER	WIDTH	WEIGHT LBS.
MDBODY391644-S	39-1/2"	120#
MDBODY391644-A	39-1/2"	104#

55½" High x 20¼" Deep

Basic body only. Shelves sold separately.

CATALOG NUMBER	WIDTH	WEIGHT LBS.
MDBODY392055-S	39-1/2"	150#
MDBODY392055-A	39-1/2"	132#

67½" High x 24" Deep

Basic body only. Shelves sold separately.

CATALOG NUMBER	WIDTH	WEIGHT LBS.
MDBODY392467-S	39-1/2"	184#
MDBODY392467-A	39-1/2"	162#



Starter unit includes two metal end sides, back panels, and kick plates. Adder unit is the same except without metal sides. All shelves must be bought separately. Standard unit comes with levelers. 2" high casters are available as an option on double faced units – see page 4.

Overall dimension shown above does not include the depth of the shelves.

Add the following depth to each face of the unit for the different type of shelf being used on the unit.

Browsing Shelf – add 7-1/2" Zig Zag display shelf – add 8-1/4"

Book display of Periodical display shelf – add 4-1/8"

Flat shelf and Face out display shelf – add 7"

Shelves and Accessories

CATALOG NUMBER	TYPE	WEIGHT LBS.
----------------	------	-------------

MDBROWSE3908 CD/DVD Browsing 5#

Storage for CD's is as follows:

5 shelves per face on 44" high, 7 per face on 55" high and 8 per face on 67" high. Each browsing shelf has 6 compartments and each shelf will hold 78 CD's.

Storage for DVD's is as follows:

4 shelves per face on 44" high, 5 per face on 55" high and 6 per face on 67" high. Each browsing shelf has 6 compartments and each shelf will hold 60 DVD's.



CATALOG NUMBER	TYPE	WEIGHT LBS.
----------------	------	-------------

MDZIGZAG39 CD/DVD 8#

MDZIGZAG39LIP CD/DVD 9#

Shelf can be ordered either with or without a front lip.

Storage for CD's is as follows:

5 shelves per face on 44" high, 7 per face on 55" high and 8 per face on 67" high. Each Zig Zag shelf has 5 compartments and each shelf will hold 60.

Storage for DVD's is as follows:

4 shelves per face on 44" high, 5 per face on 55" high and 6 per face on 67" high. Each Zig Zag shelf has 5 compartments and each shelf will hold 45.



CATALOG NUMBER	TYPE	WEIGHT LBS.
----------------	------	-------------

MDBOOKDIS3905 New Book 9#

MDPERDIS3905 Periodical 10#

New book display shelf has 6 compartments for displaying new books.

Periodical shelf has 10 compartments for displaying periodicals.



CATALOG NUMBER	TYPE	WEIGHT LBS.
----------------	------	-------------

MDFOD3908 New Book /Periodicals 9#

MDBKS3908 Above shelf with brackets 10#

Face out display shelf can be used to display books, periodicals or any other media.

Shelf is provided with brackets underneath the shelf for clear display from one section to the adjacent section or an above the shelf end bracket can be added to create separation.

Brackets can be added at a later date if so desired.



Shelves and Accessories

CATALOG NUMBER	TYPE	WEIGHT LBS.
MDAS3908	Flat shelf	8
4 shelves per face on 44" high, 5 per face on 55" high and 6 per face on 67" high.		

CATALOG NUMBER	TYPE	WEIGHT LBS.
MDSIGN	Sign Holder	1
Sign holder is designed to accept ¼" thick plexiglass or poster board. Sign or plexiglass not included.		

CATALOG NUMBER	TYPE	WEIGHT LBS.
MDCASTER2	Caster	1
Four casters per starter unit and two per adder unit are required.		



The MJ Advantages

- Sloping nature of unit allows for easy accessibility and visual browsing
- Prominent display of CD's, DVD's, periodicals and new books
- Ability to customize your display to suit your demands
- Integrated signage allows creation of custom inserts
- Casters are available to easily move units to create different spaces in the library
- Custom end panels and back panels are easily mounted to accent any interior space
- Various options of materials for back panels or end panels from fabric to laminate to vinyl or wood are available
- Our state-of-the-art powder coating paint system gives us the most durable paint finish in the industry
- All this and you still get the quality that has become synonymous with the MJ Library name

We have a nationwide sales organization which is fully trained to assist you with your library planning.

Contact Aurora Storage at **1-800-277-1699** for the name of your local dealer.

 **Material Handling USA**
800-326-4403
<https://www.mh-usa.com/>

 **Material Handling USA**
Call Now for a Free Quote or Site Visit!
 222 S. Main St. 5th Floor
 Salt Lake City, UT 84101
 800-326-4403
<https://www.mh-usa.com/>
 Material Handling USA

SUPERSTORE

MH-USA

Escalook™



 **Material Handling USA**
800-326-4403
<https://www.mh-usa.com/>

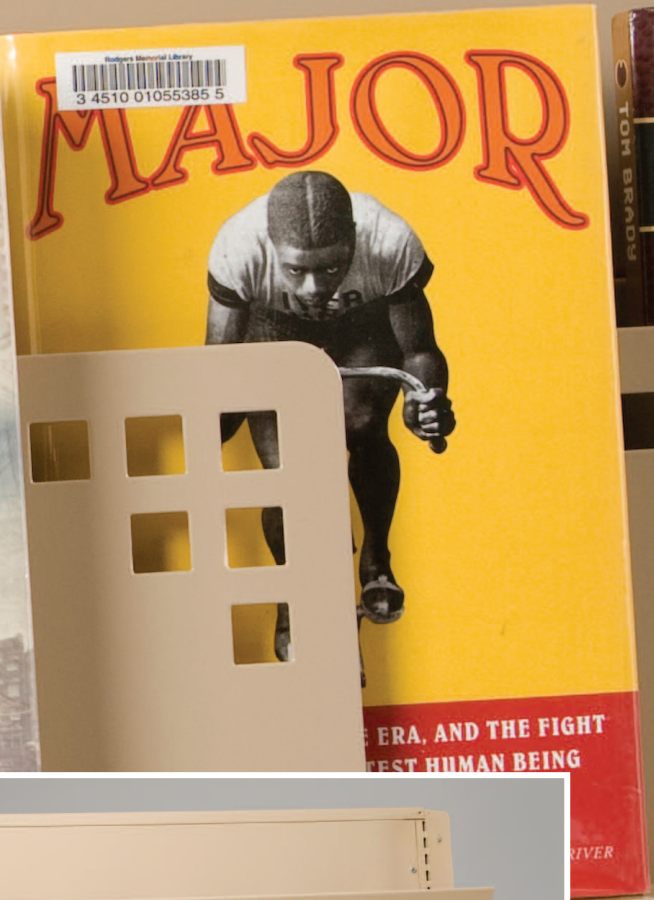



The Aurora MJ Library Advantages

- Prominent display of CD's, DVD's, periodicals and new books.
- Easy accessibility of visual media due to the sloping nature of the shelving.
- All units are mounted on casters so they can be easily moved to create different spaces in the library.
- Sleek smooth design lends itself to today's libraries.
- Component parts can be easily added and displayed at the ends of the ranges.
- Our state-of-the-art powder coating paint system gives us the most durable paint finish in the industry. Special colors can be matched to please even the most discriminating eye.
- On time delivery. Most deliveries can be made in eight to ten weeks after receipt of order.
- All this and you still get the quality that has become synonymous with the Aurora MJ Library name.

We have a nationwide sales organization which is fully trained to assist you with your library planning. Contact Aurora Storage Products at **1-800-277-1699** for the name of your local dealer.



Single Faced Base

44" High X 13³/₁₆" Deep

Basic body only. Shelves sold separately.

CATALOG NUMBER	WIDTH	WEIGHT LBS.
ESBODY391344-S	39 ¹ / ₂ "	64
ESBODY391344-A	39 ³ / ₈ "	54

56¹/₄" HIGH X 15⁷/₈" DEEP

Basic body only. Shelves sold separately.

CATALOG NUMBER	WIDTH	WEIGHT LBS.
ESBODY391656-S	39 ¹ / ₂ "	85
ESBODY391656-A	39 ³ / ₈ "	71

68³/₄" High X 18¹/₂" Deep

Basic body only. Shelves sold separately.

CATALOG NUMBER	WIDTH	WEIGHT LBS.
ESBODY391869-S	39 ¹ / ₂ "	102
ESBODY391869-A	39 ³ / ₈ "	86

Double Faced Base

44" High X 26³/₄" Deep

Basic body only. Shelves sold separately.

CATALOG NUMBER	WIDTH	WEIGHT LBS.
ESBODY392744-S	39 ¹ / ₂ "	120
ESBODY392744-A	39 ³ / ₈ "	104

56¹/₄" High X 32¹/₄" Deep

Basic body only. Shelves sold separately.

CATALOG NUMBER	WIDTH	WEIGHT LBS.
ESBODY393256-S	39 ¹ / ₂ "	150
ESBODY393256-A	39 ³ / ₈ "	132

68³/₄" High X 37¹/₂" Deep

Basic body only. Shelves sold separately.

CATALOG NUMBER	WIDTH	WEIGHT LBS.
ESBODY393869-S	39 ¹ / ₂ "	184
ESBODY393869-A	39 ³ / ₈ "	162

Starter unit includes two side supports, back panels, and kick plate. Adder unit is the same except only one side support. All shelves must be bought separately.



Shelves and Accessories



CATALOG NUMBER	TYPE	WEIGHT LBS.
ES-AS3908	Flat Shelf	8#

3 Shelves per face for 44" high, 4 per face on 56" high, 5 per face for 69" high.

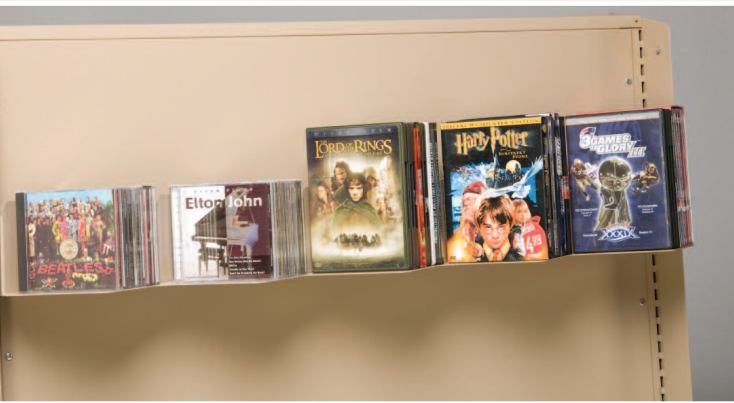

CATALOG NUMBER	TYPE	WEIGHT LBS.
ES-ZIGZAG39	Zig-Zag	8#

Storage for CD's is as follow:
5 Shelves per face on 44" high, 7 per face on 56" high, 9 per face on 69" high. Each zigzag shelf has 5 compartments and each shelf will hold 60.

Storage for DVD's is as follows:
4 Shelves per face on 44" high, 6 per face on 56" high, 7 per face on 69" high. Each zigzag shelf has 5 compartments and each shelf will hold 45.



CATALOG NUMBER	TYPE	WEIGHT LBS.
ES-BOOKDIS3905	Book Shelf	9#

New Book display shelf has 5 compartments for displaying new books.

CATALOG NUMBER	TYPE	WEIGHT LBS.
ES-BROWSE3908	CD Browsing	5#

Storage for CD's is as follows:
5 Shelves per face on 44" high, 7 per face on 56" high, 9 per face on 69" high. Each browsing shelf has 6 compartments and each shelf will hold 78.



Storage for DVD's is as follows:
4 Shelves per face on 44" high, 6 per face on 56" high, 7 per face on 69" high. Each browsing shelf has 6 compartments and each shelf will hold 60.



CATALOG NUMBER	TYPE	WEIGHT LBS.
ES-PERDIS3905	Periodicl Shelf	10#

Periodical shelf has 8 compartments for displaying periodicals.

