

Eliminator Fume Hood Series

product catalog



 **Material Handling USA**
800-326-4403
<https://www.mh-usa.com/>





Since 1975, Air Master Systems has manufactured chemical fume hoods, filtration hoods, and laboratory furniture for the R&D, institutional, industrial, government and biotech markets.

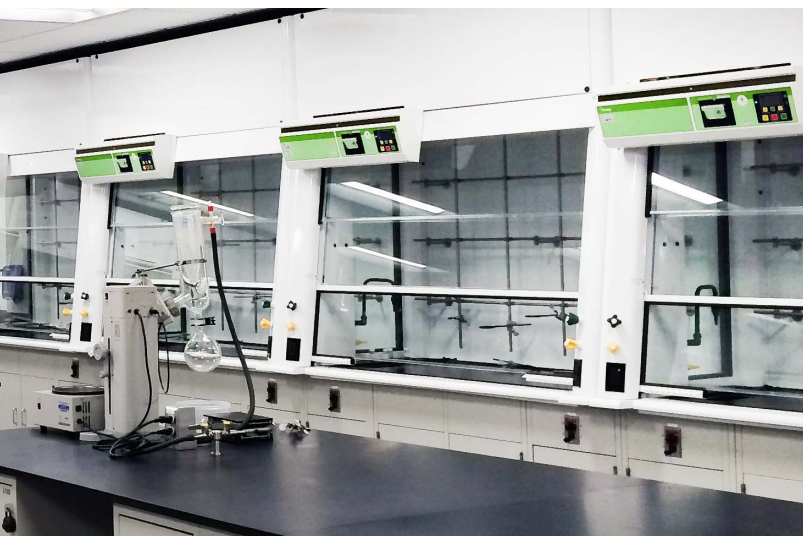

Contents

The Green Solution Hood (Chemical Filtration)	4
Eliminator Series	8
Eliminator HP Series High Performance Energy Efficient Hood	8
Eliminator 100 Series Airfoil Fume Hood	10
Eliminator 200 Series Double Faced 100 Series Hood	12
Eliminator 300 Series Thin Wall Hood	14
Eliminator 400 Series Floor Mounted Hood	16
Eliminator 500 Series ADA Hood (Barrier Free Design)	18
Eliminator 600 Series Radio Isotope Hood	20
Eliminator 700 Series Perchloric Acid Hood	22
Eliminator 800 Series Flat Front Hood	24
Eliminator 900 Series Demonstration Hood	26
Eliminator Paint (Spray) Booth	28
Portable Hood	30
Canopy Hoods	31
Updraft/Downdraft Hoods	32
Air Monitor Alarms	33
Ceiling Enclosures and Finished Backs	34
Plumbing Accessories	35
Electrical Accessories and Specifications	36
Base Cabinets	37
Flammable and Acid Storage Cabinets	38
Vacuum Pump Cabinet	39
Hood Base Frame	39
Sash Options	40
Epoxy Resin and Stainless Steel Surfaces	42
Custom Stainless Steel Countertops	45
Knock Down Hoods	46
Fume Hood General Design Requirements	47
Glossary	51

Note:

Images in this catalog are for representation only. For complete product specifications, contact your AMS representative.



800-326-4403

222 S. Main St. 5th Floor, Salt Lake City, UT 84101

| <https://www.mh-usa.com/> | 800-362-4403

The Green Solution Hood

***The Green Solution Hood with proprietary Neutrodine® Filtration Technology:
Save energy without compromising usage, performance or safety.***

With the breakthrough Neutrodine® system by ErLab®—offers a revolutionary turnkey solution providing a variety of installation, operational and environmental benefits to virtually any laboratory. Compared to traditional fume hoods in operation today, The Green Solution Hood with Neutrodine® Technology enables labs to:

- ❑ Add a fume hood without affecting building HVAC.
- ❑ Save Energy while maintaining 100 fpm face velocity.
- ❑ Cut energy costs by 96% and reduce operating costs by 70%.
- ❑ Handle liquids and solids (Including acids, bases, solvents and powders)—individually or together—with a single hood.
- ❑ Virtually eliminate installation costs.
- ❑ Operate safely without polluting and contaminating the environment.
- ❑ Maintain productivity without changing the way lab technicians work.
- ❑ All hoods commissioned by factory personnel.
- ❑ All fume hoods are certified with a Life Cycle Payback. This certification by out lab assures researcher safety as well as economic feasibility.



The Green Solution Hood

CHALLENGING PRECONCEIVED IDEAS

1 All manufacturers' products are similar.

Not any more: The Green Solution Hood is a filtering fume hood that uses multitask Neutrodine® filtration technology instead of standalone carbon filtration commonly found in application-specific products known as ductless fume hoods. Furthermore, The Green Solution Hood combines the highly versatile proprietary Neutrodine® filtration technology with the revolutionary gGuard monitoring package to offer a much larger usage spectrum than has ever been available before. Neutrodine®—which is in compliance with the ASHRAE 110-1995 and AFNOR NF X 15-211 filtration standards—enables The Green Solution Hood to exhaust 100 times less toxic contaminants than are allowed by the official TLV while maintaining the industry's preferred 100 fpm face velocity at various working sash heights. In addition, gGuard gives The Green Solution Hood owners total control and an unprecedented level of safety.

2 There are a great variety of chemicals in the lab and carbon filters are too specific.

Not any more: Neutrodine® can handle the majority of chemicals traditionally used in laboratories. Furthermore, thanks to the world's first Adaptable Modular Filtration Column (AMFC), The Green Solution Hood can handle liquids and powders—either individually or together—even in a cleanroom environment.

3 Heavier molecules can push out lighter molecules.

Not any more: This problem only occurs with low quality carbons or carbons that are specifically designed to desorb such as the carbon used in industrial filters to recover solvents. Neutrodine® filtration technology uses a proprietary high quality carbon with a plurality of pores so large and diverse that both light and heavy molecules are retained independent of one another.

If high quality carbon were able to desorb, military gas masks would be rendered useless by an enemy simply releasing a heavier gas. Obviously this isn't the case. High quality carbon is trusted in applications worldwide, even when—as in this example—reliability is a matter of life and death.

4 In the event of a spill, carbon filtration has limited capacity for containing large concentrations of chemicals.

Not any more: The Green Solution Hood uses Neutrodine® Technology instead of the standalone carbon filters found in limited application ductless fume hoods. Test reports show that The Green Solution Hood with Neutrodine® Technology delivers back-up redundancy capabilities capable of containing chemical spills in excess of 1 gallon.

5 Carbon filtration requires controlled conditions, operator intervention and constant monitoring. Ducted fume hoods are much simpler to use.

Not any more: Unlike application-specific products that require operator intervention, The Green Solution Hood with Neutrodine® Technology is very simple to use. Activating an on/off switch is the only responsibility required from the operator. All other functions are controlled and monitored with the help of the gGuard management package. This system—which uses proprietary software developed with Microsoft® technologies—makes The Green Solution Hood with Neutrodine® Technology easier to use since safety-related functions are taken out of the hands of the operator and handled remotely, and constantly, by the person(s) in charge of safety. The Green Solution Hood with Neutrodine® Technology also features a series of innovative detectors and monitors that provide a wealth of operational information and management capabilities never before seen in a laboratory fume hood.

6 Filters are expensive and difficult to change.

Not any more: Unlike previous generations of filters, we are able to estimate the life of your filters with our Life Cycle Payback. Simply fill out our questionnaire to find out if our system is not only safe for your application, but economical as well. When it comes time to change the filters, no special tools are required and you will be back up and running within an hour.

The Green Solution Hood

The Green Solution Hood and its patented Neutrodine® filtration system by ErLab® use molecular adsorption to handle fumes from acids, solvents, liquids, and even powders with the use of a HEPA filter accessory, together or individually all under the same hood.

THE GREEN SOLUTION HOOD

Unprecedented safety in a hood that uses 96% less energy than standard hoods and has an operating cost 70% lower.

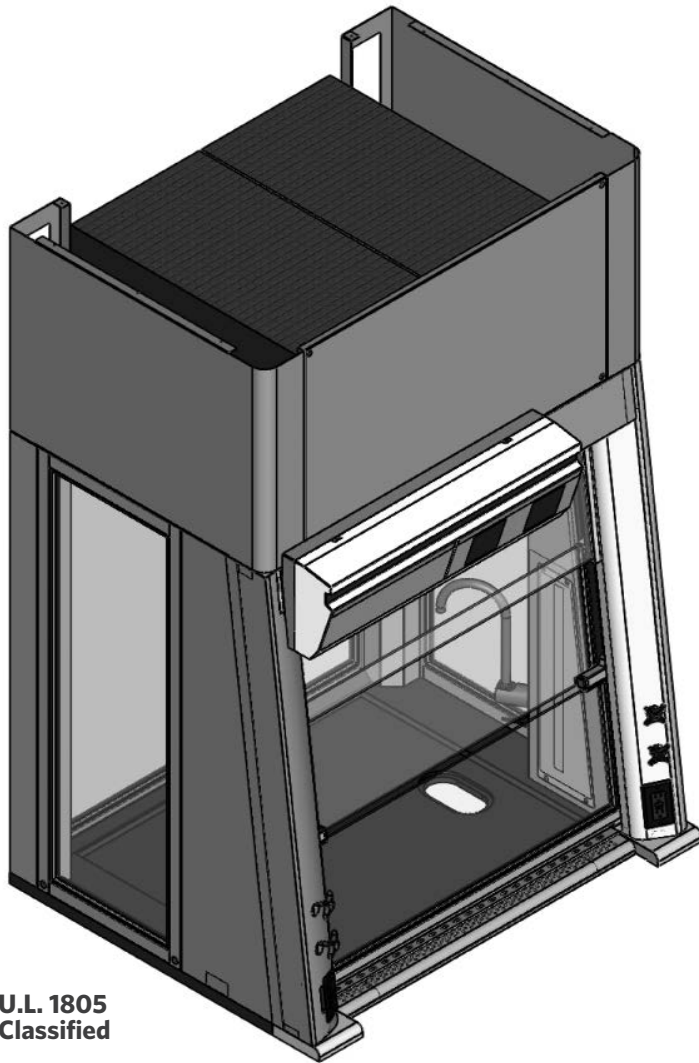

**U.L. 1805
Classified**

- 360 degree viewing
- Powder coat finish
- Flush-mount airfoil/trough
- Integral sash counterbalance
- Epoxy top
- Sliding pass-by sashes
- Interior access to plumbing
- Front mount service fixtures
- Plumbing outlets within arm's reach
- Full 28" hood opening
- GFI receptacles

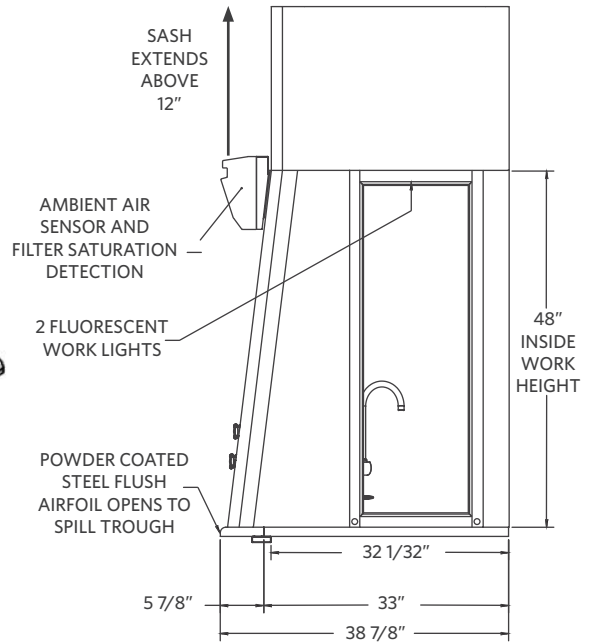

Part Number	Superstructure			Worktop			Hood Opening		Shipping Weight
	W	H	D	W	H	D	W	H	
SFH-482	48"	71-7/16"	38-7/8	48"	1-1/4"	33"	38"	28"	375
SFH-602	60"	71-7/16"	38-7/8	60"	1-1/4"	33"	50"	28"	425
SFH-724	72"	71-7/16"	38-7/8	72"	1-1/4"	33"	62"	28"	475
SFH-962	96"	71-7/16"	38-7/8	96"	1-1/4"	33"	86"	28"	575

100fpm @ 12" open; 60fpm @ 18" open

The Green Solution Hood

The Green Solution Hood can be remotely accessed with the use of a gGuard Onsite with a PC/pocket device or gGuard online which provides both monitoring and maintenance services via the Internet. gGuard will tell you real-time filter condition, sash position, blower motor speed, filter saturation level, ambient laboratory air, enclosure temperature, energy savings data and usage time. Hoods can also be incorporated into a building automation system.

THE GREEN SOLUTION HOOD

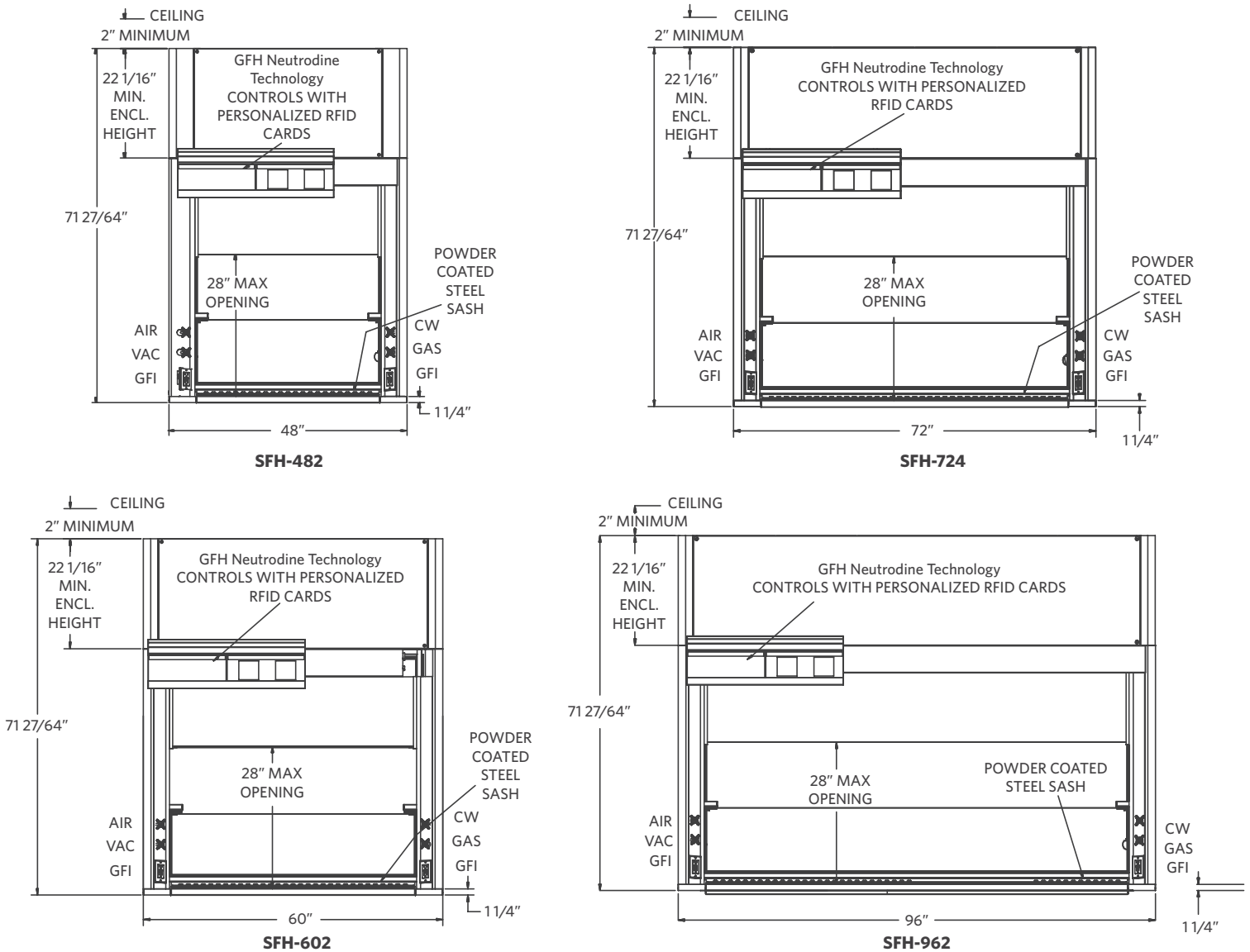

The Eliminator HP Series

The Eliminator HP hood comes standard with all the same features as other Eliminator models, along with some additional innovations to set this hood apart from its competitors.

THE ELIMINATOR HP SERIES

High Performance/Energy Efficient - A Green Alternative



- Powder coat finish
- Full frame construction
- Shaft drive sash
- U.L. listed poly resin liner
- Flush-mount airfoil
- Knock down capability
- T-8 fluorescent light with bulbs
- Full-length finger lift
- Sash sweep
- 25.5" interior working depth
- LED light available

U.L. 1805 Classified

- 60 PFM
- Fits through standard door
- 30" Countertop

The HP Eliminator is THE hood for remodeling, new construction, or retrofitting.

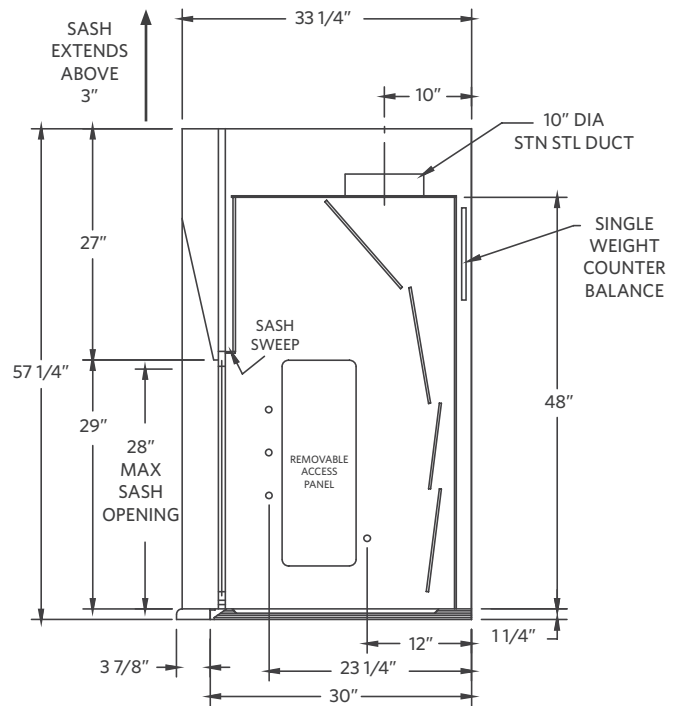

Part Number	Superstructure			Worktop			Hood Opening		CFM @ 28"*	CFM @ 18"*	SP	Blower Model #	Shipping Weight
	W	H	D	W	H	D	W	H					
EH-HP-48	48"	56"	33-1/4"	48"	1-1/4"	30"	38"	28"	469	313	.25	BL-HP-48	415
EH-HP-60	60"	56"	33-1/4"	60"	1-1/4"	30"	50"	28"	619	413	.34	BL-HP-60	490
EH-HP-72	72"	56"	33-1/4"	72"	1-1/4"	30"	62"	28"	769	513	.34	BL-HP-72	535
EH-HP-96	96"	56"	33-1/4"	96"	1-1/4"	30"	86"	28"	1069	713	.34	BL-HP-96	570

*Height of open sash; CFM calculated at 60 FPM
For High Performance VAV Hoods, add -VAV to the part number.

The Eliminator HP Series

The HP model is designed to operate economically while creating a safe work environment without compromising containment. By operating at 60 FPM, air flow across the sash opening results in a 40% savings in fume hood operation costs. Features of the HP Series include:

- Passed ASHRAE 110 AM testing with sash in full open position.
- Standard 30" deep work surface for zero work space loss in your lab. Other depths available.

THE ELIMINATOR HP SERIES

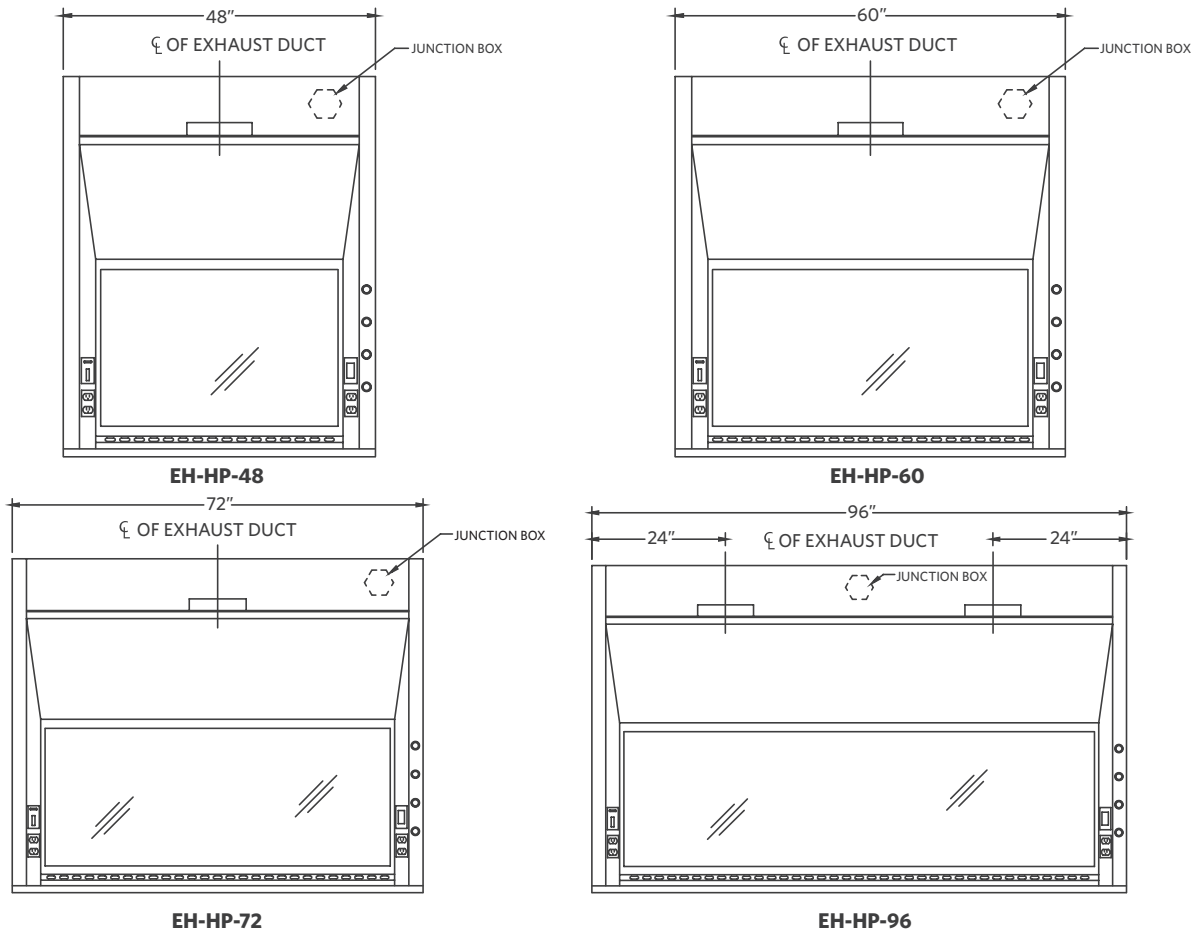

Accessories

ITEM	AMS PT#	PAGE #	ITEM	AMS PT#	PAGE #
Ceiling Enclosures	CE	33	Sash Stops	SASHSTOP	38
Plumbing Accessories		34	Chain and Sprocket Drive	CHNSPK	CALL
Electrical Accessories		35	Stainless Steel Sash	SS SASH	38
Epoxy Tops	ET	39	Stainless Steel Airfoil	SS AF	
Alarms	ALARM	32	Push Button Sash	PUSH BUTTON	38
Base Cabinets	BC	36	Combination Sash	H&V	38
Blowers	BL	CALL	Lattice Assembly	LATTICE	CALL
Pre-Plumbing	PREP		Auto Sash Return		38
Pre-Wiring	PREW				

The Eliminator 100 Series

The EH-100 series airfoil-type fume hood features a 45-degree angle around the fascia and a flush-mount radiused airfoil across the bottom, which results in minimized turbulence and increased performance. Like the exterior of the hood, the airfoil is made from chemical-resistant, powder-coated, 16-gauge cold rolled steel. A stainless steel airfoil is available as an option. Posts are 5" (127 mm) wide.

Five standard sizes offer design flexibility, or we'll customize to your specific needs.

ELIMINATOR 100 SERIES - AIRFOIL FUME HOOD

Airfoil Fume Hood - Minimized Turbulence, Increased Performance



**U.L. 1805
Classified**

- Powder coat finish
- Full frame construction
- Shaft drive sash
- U.L. listed poly resin liner
- T-8 fluorescent light with bulbs
- Flush-mount airfoil
- Knock down capability
- Full-length finger lift
- Louvered front for by-pass
- 10" round S/S duct collar

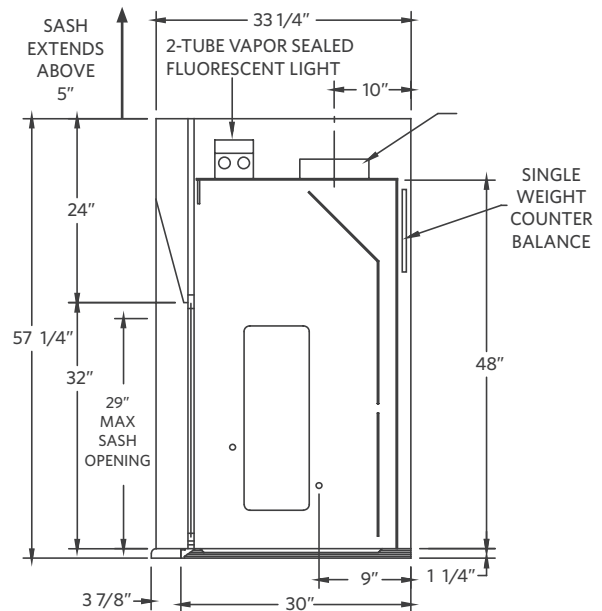

Part Number	Superstructure			Worktop			Hood Opening		CFM @ 29"*	CFM @ 18"*	SP	Blower Model #	Shipping Weight
	W	H	D	W	H	D	W	H					
EH-111-36	36"	56"	33-1/4"	36"	1-1/4"	30"	26"	29"	567	354	.25	BL-100-36	320
EH-111-48	48"	56"	33-1/4"	48"	1-1/4"	30"	38"	29"	833	521	.25	BL-100-48	385
EH-111-60	60"	56"	33-1/4"	60"	1-1/4"	30"	50"	29"	1100	688	.34	BL-100-60	450
EH-111-72	72"	56"	33-1/4"	72"	1-1/4"	30"	62"	29"	1367	854	.34	BL-100-72	510
EH-111-96	96"	56"	33-1/4"	96"	1-1/4"	30"	86"	29"	1900	1188	.40	BL-100-96	630

The Eliminator 100 Series

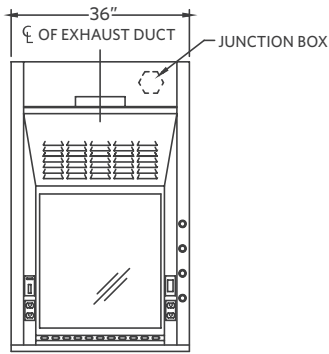

EH-111-36

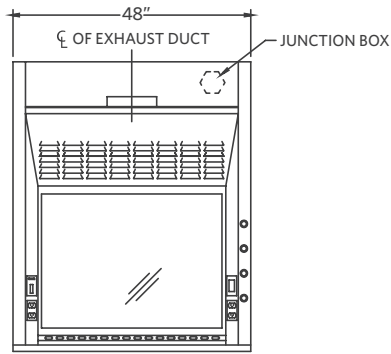

EH-111-48

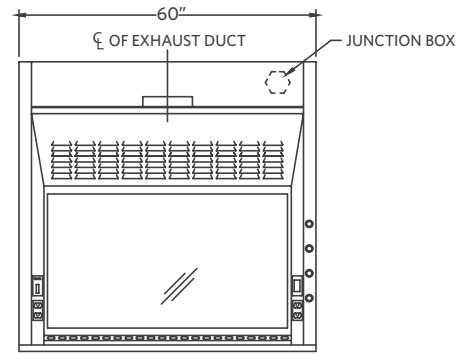

EH-111-60

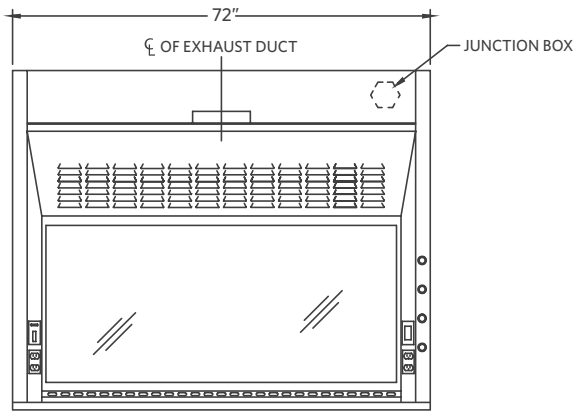

EH-111-72

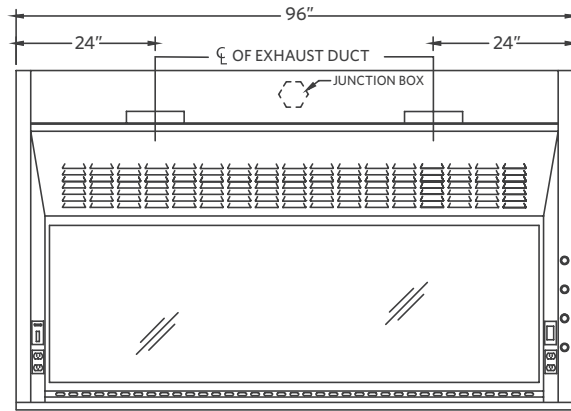

EH-111-96

Accessories

ITEM	AMS PT#	PAGE #	ITEM	AMS PT#	PAGE #
Ceiling Enclosures	CE	33	Sash Stops	SASHSTOP	38
Plumbing Accessories		34	Chain and Sprocket Drive	CHNSPK	CALL
Electrical Accessories		35	Stainless Steel Sash	SS SASH	38
Epoxy Tops	ET	39	Stainless Steel Airfoil	SS AF	
Alarms	ALARM	32	Push Button Sash	PUSH BUTTON	38
Base Cabinets	BC	36	Combination Sash	H&V	38
Blowers	BL	CALL	Lattice Assembly	LATTICE	CALL
Pre-Plumbing	PREP		Auto Sash Return	AUTO RETURN	38
Pre-Wiring	PREW				

The Eliminator 200 Series

The Eliminator 200 series provides the same aerodynamic design features as the EH-100 airfoil hood series, with entrance from two sides. This makes it ideal for use in classroom or prep room settings or whenever demonstration of experiments is desired. A 45-degree angle around the fascia and a flush-mount radiused airfoil across the bottom provide minimized turbulence and increased performance.

ELIMINATOR 200 - DOUBLE-SIDED 100 SERIES

Double-Sided 100 Series - Dual Access



**U.L. 1805
Classified**

- Powder coat finish
- Full frame construction
- U.L. listed poly resin liner
- Flush-mount airfoil
- Knock down capability
- T-8 fluorescent light with bulbs
- Full-length finger lift
- Louvered front for by-pass
- 10" round S/S duct collar

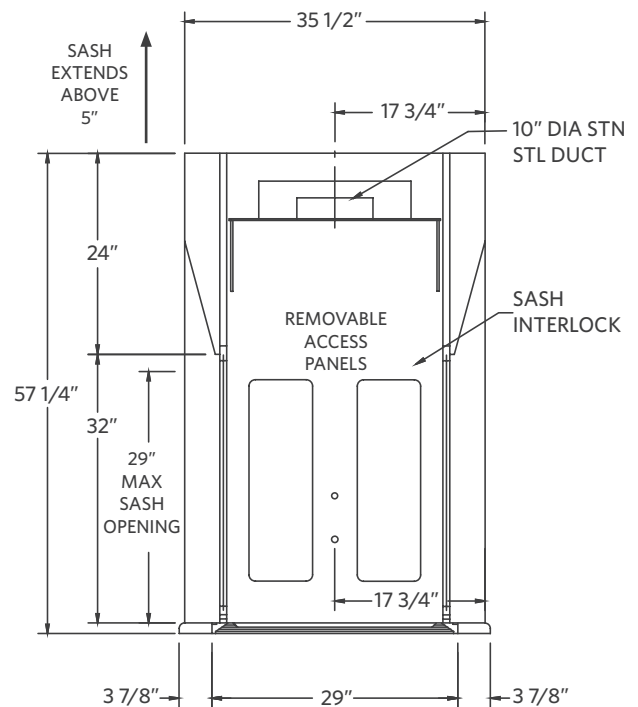

Part Number	Superstructure			Worktop			Hood Opening		CFM @ 29"*	CFM @ 18"*	SP	Blower Model #	Shipping Weight
	W	H	D	W	H	D	W	H					
EH-211-36	36"	56"	35-1/2"	36"	1-1/4"	29"	26"	29"	567	354	.25	BL-100-36	400
EH-211-48	48"	56"	35-1/2"	48"	1-1/4"	29"	38"	29"	833	521	.33	BL-100-48	450
EH-211-60	60"	56"	35-1/2"	60"	1-1/4"	29"	50"	29"	1100	688	.34	BL-100-60	500
EH-211-72	72"	56"	35-1/2"	72"	1-1/4"	29"	62"	29"	1367	854	.34	BL-100-72	550
EH-211-96	96"	56"	35-1/2"	96"	1-1/4"	29"	86"	29"	1900	1188	.40	BL-100-96	650

The Eliminator 200 Series

The EH-200 features standard 5" (127 mm) posts to allow for electrical and remote control plumbing services on both sides, and these can be configured to your exact specifications.

Five standard sizes and an array of options make this one of the most flexible fume hoods available anywhere.

ELIMINATOR 200 - DOUBLE-SIDED 100 SERIES

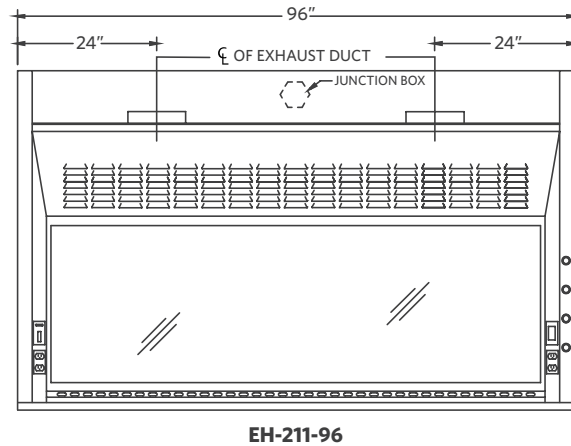
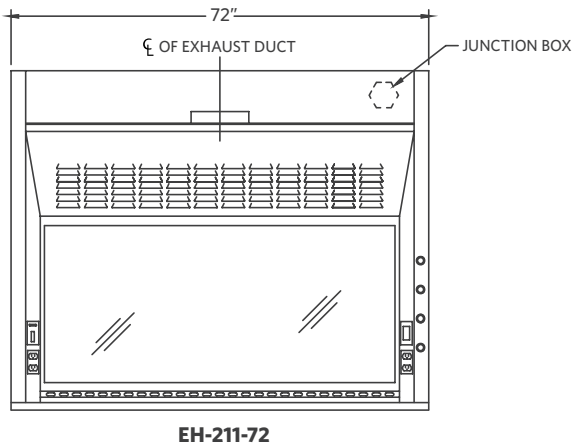
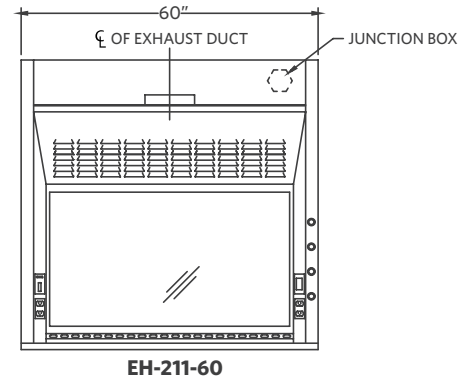
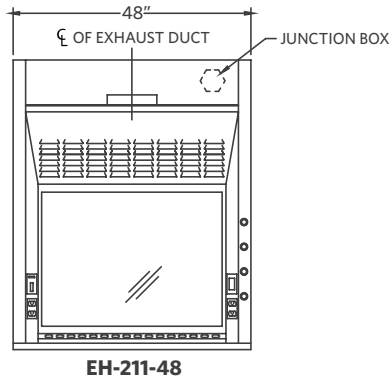
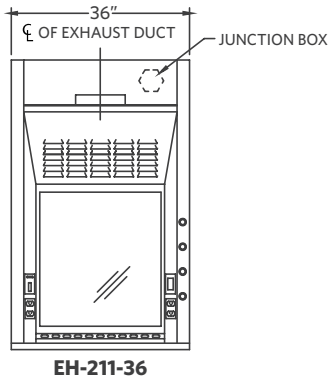

Accessories

ITEM	AMS PT#	PAGE #	ITEM	AMS PT#	PAGE #
Ceiling Enclosures	CE	33	Sash Stops	SASHSTOP	38
Plumbing Accessories		34	Chain and Sprocket Drive	CHNSPK	CALL
Electrical Accessories		35	Stainless Steel Sash	SS SASH	38
Epoxy Tops	ET	39	Stainless Steel Airfoil	SS AF	
Alarms	ALARM	32	Push Button Sash	PUSH BUTTON	38
Base Cabinets	BC	36	Combination Sash	H&V	38
Blowers	BL	CALL	Lattice Assembly	LATTICE	CALL
Pre-Plumbing	PREP		Auto Sash Return	AUTO RETURN	38
Pre-Wiring	PREW				

The Eliminator 300 Series

The Eliminator 300 series is a thin-wall fume hood with slimmer front posts to expand the workspace. Posts are 2-1/2" (64 mm) wide.

Because the slimmer posts remove the option for wiring and plumbing in the posts, plumbing services must be deck mounted. Optional light and blower switches can be mounted on the post.

Five standard widths with unlimited heights and depths are available, making this one of the most flexible fume hoods available anywhere.

ELIMINATOR 300 - THIN WALL

Thin Wall - Expanded Workspace



**U.L. 1805
Classified**

- Powder coat finish
- Full frame construction
- Shaft drive sash
- U.L. listed poly resin liner
- T-8 fluorescent light with bulbs
- Knock down capability
- Full-length finger lift
- Louvered front for by-pass

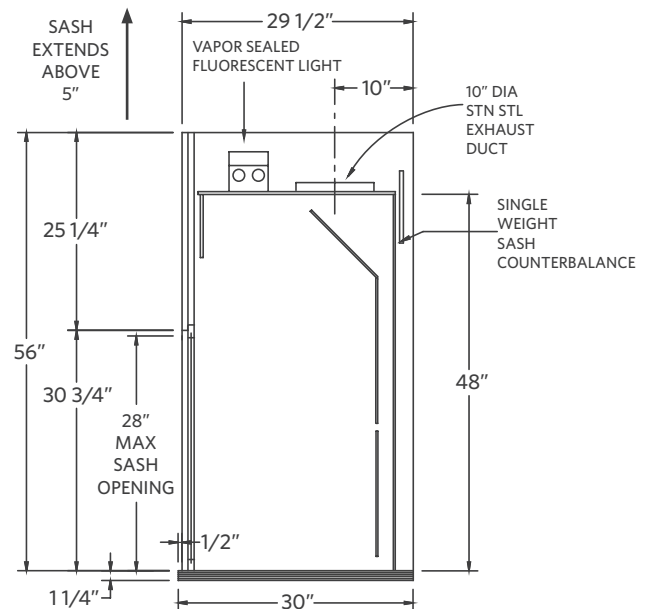

Part Number	Superstructure			Worktop			Hood Opening		CFM @ 28"*	CFM @ 18"*	SP	Blower Model #	Shipping Weight
	W	H	D	W	H	D	W	H					
EH-311-36	36"	56"	29-1/2"	36"	1-1/4"	30"	26"	28"	646	431	.25	BL-300-36	190
EH-311-48	48"	56"	29-1/2"	48"	1-1/4"	30"	43"	28"	896	597	.25	BL-300-48	175
EH-311-60	60"	56"	29-1/2"	60"	1-1/4"	30"	55"	28"	1146	764	.39	BL-300-60	200
EH-311-72	72"	56"	29-1/2"	72"	1-1/4"	30"	67"	28"	1417	944	.37	BL-300-72	250
EH-311-96	96"	56"	29-1/2"	96"	1-1/4"	30"	91"	28"	1896	1264	.43	BL-300-96	275

The Eliminator 300 Series

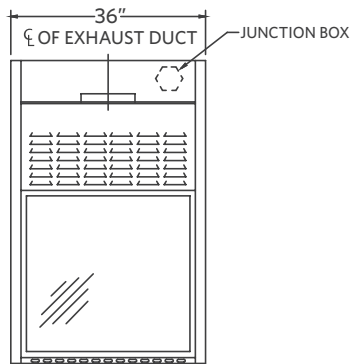

EH-311-36

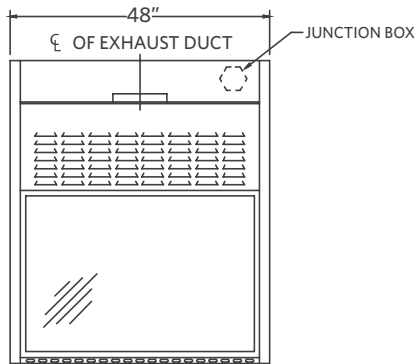

EH-311-48

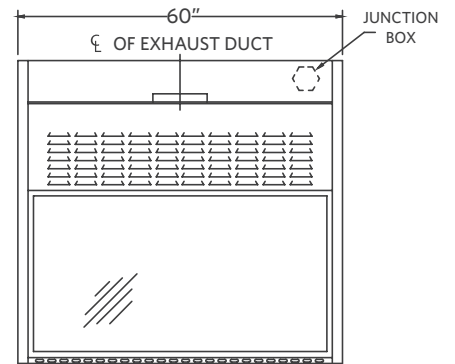

EH-311-60

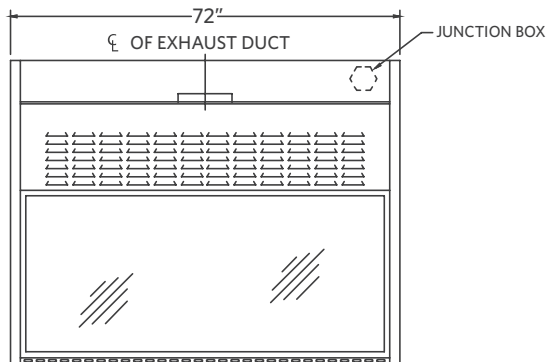

EH-311-72

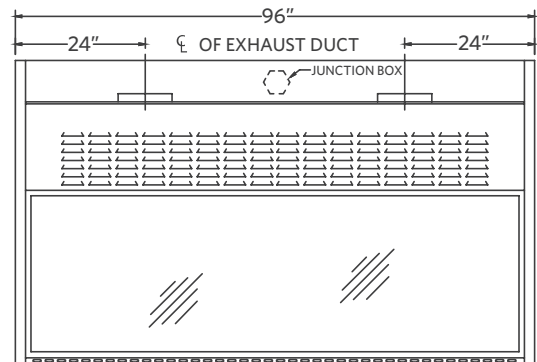

EH-311-96

Accessories

ITEM	AMS PT#	PAGE #	ITEM	AMS PT#	PAGE #
Ceiling Enclosures	CE	33	Sash Stops	SASHSTOP	38
Plumbing Accessories		34	Chain and Sprocket Drive	CHNSPK	CALL
Electrical Accessories		35	Stainless Steel Sash	SS SASH	38
Epoxy Tops	ET	39	Combination Sash	H&V	38
Alarms	ALARM	32	Lattice Assembly	AUTO RETURN	CALL
Base Cabinets	BC	36	Auto Sash Return	LATTICE	38
Blowers	BL	CALL			

The Eliminator 400 Series

The Eliminator 400 series, with a double-hung sash configuration and 72" high opening, is designed to accommodate a large-apparatus application, up to 85" in height. Posts are 5" (127 mm) wide. **Many heights and depths are available.** Contact AMS to find the right size hood for your application.

And with the AMS exclusive knock-down ability, even a hood this big is a breeze to install, maintain, repair and move.

ELIMINATOR 400 - FLOOR MOUNTED

Floor Mounted Hoods - For Those Tall Experiments



**U.L. 1805
Classified**

- Powder coat finish
- Full frame construction
- Shaft drive sash
- U.L. listed poly resin liner
- T-8 fluorescent light with bulbs
- Knock down capability
- Full-length finger lift
- Louvered front for by-pass

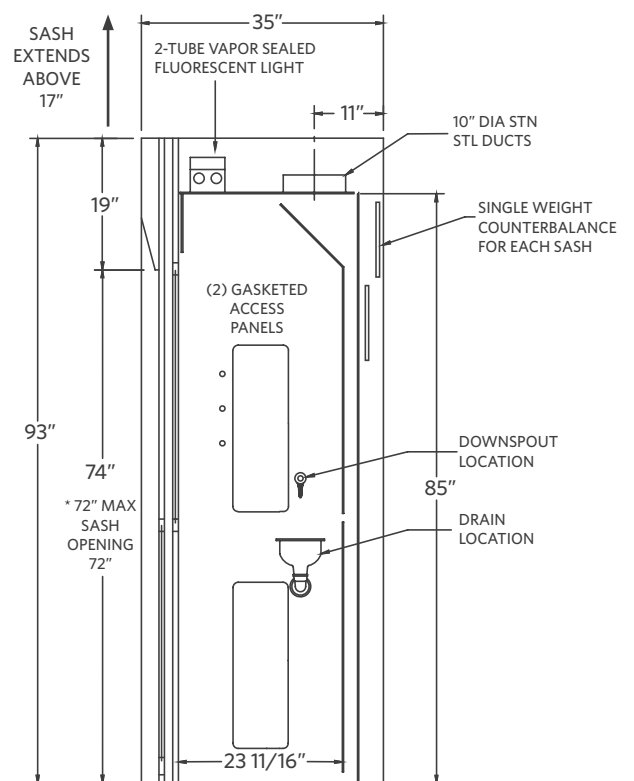

Part Number	Superstructure			Hood Opening		CFM@18"	CFM @ 36"*	CFM @ 72"*	SP	Blower Model #	Approx. Shipping Weight
	W	H	D	W	H						
EH-411-48	48"	93"	35"	38"	72"	445	990	1979	.25	BL-400-48	560
EH-411-60	60"	93"	35"	50"	72"	653	1306	2613	.34	BL-400-60	675
EH-411-72	72"	93"	35"	62"	72"	812	1623	3246	.50	BL-400-72	790
EH-411-96	96"	93"	35"	86"	72"	1128	2256	4513	.34	BL-400-96	1025
EH-411-120	120"	93"	35"	108"	72"	1444	2889	5780	.58	BL-400-120	2500

The Eliminator 400 Series

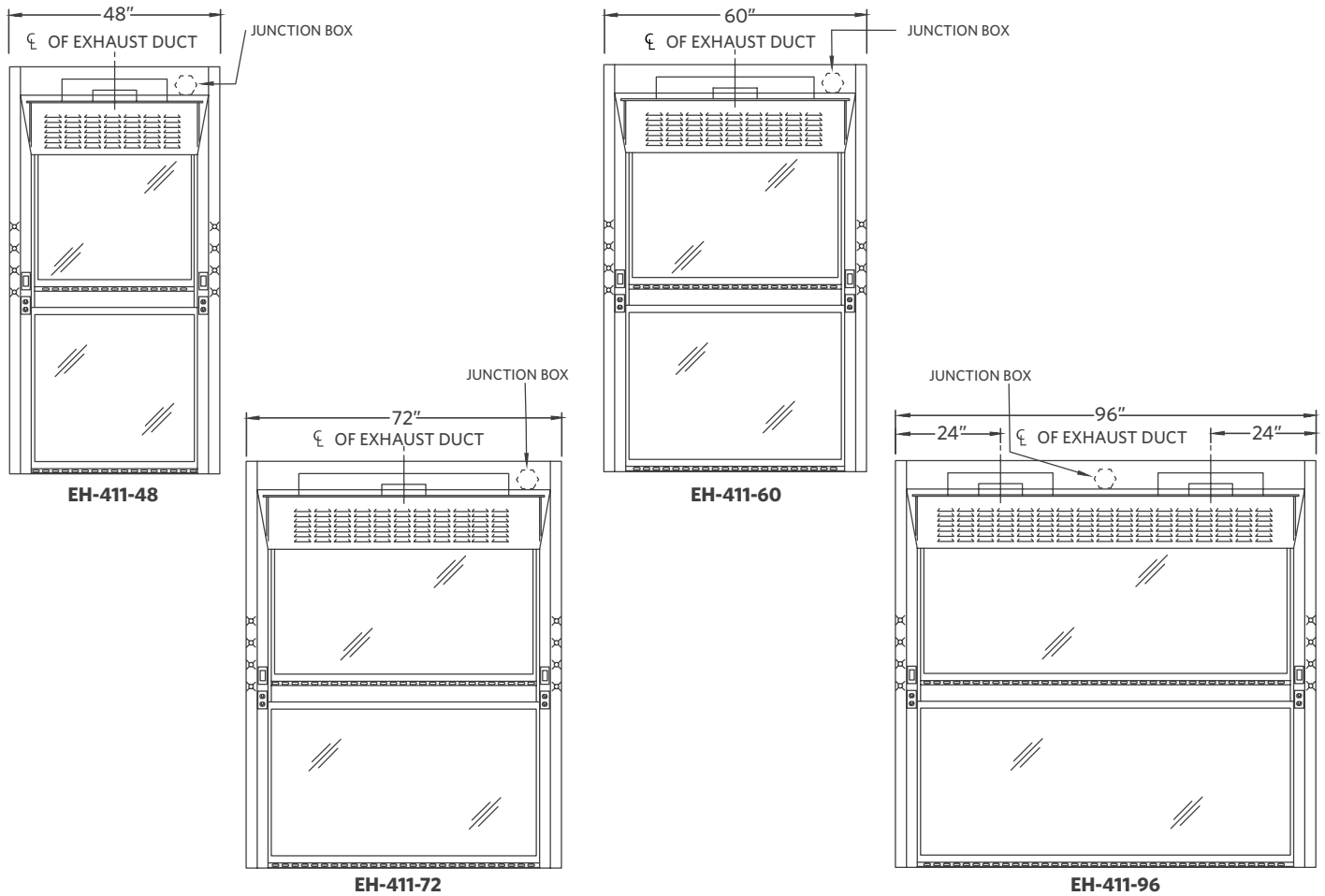

Accessories

ITEM	AMS PT#	PAGE #	ITEM	AMS PT#	PAGE #
Ceiling Enclosures	CE	33	Sash Stops	SASHSTOP	38
Plumbing Accessories		34	Chain and Sprocket Drive	CHNSPK	CALL
Electrical Accessories		35	Stainless Steel Sash	SS SASH	38
Alarms	ALARM	32	Horizontal Hanging Doors	HHD	38
Blowers	BL	CALL	Combination Sash	H&V	38
Pre-Plumbing	PREP		Lattice Assembly	LATTICE	CALL
Pre-Wiring	PREW		SS Ramp	RAMP	CALL

The Eliminator 500 Series

The Eliminator 500 series is an airfoil-type fume hood designed to meet ADA dimensional guidelines. A 45-degree angle around the fascia and a flush-mount radiused airfoil across the bottom result in minimized turbulence and increased performance. The ADA hood's airfoil flips back out of the way for cleanup. Under the airfoil is a containment trough to capture accidental spills that may flow over the dished work surface.

ELIMINATOR 500 - ADA DESIGN

ADA Design - Meets ADA Dimensional Guidelines

- Powder coat finish
- Full frame construction
- Shaft drive sash
- U.L. listed poly resin liner
- T-8 fluorescent light with bulbs
- Flush-mount airfoil
- Knock down capability
- Full-length finger lift
- Louvered front for by-pass
- Painted steel trough assembly
- Sash stop
- 1/4 turn ball valves



**U.L. 1805
Classified**

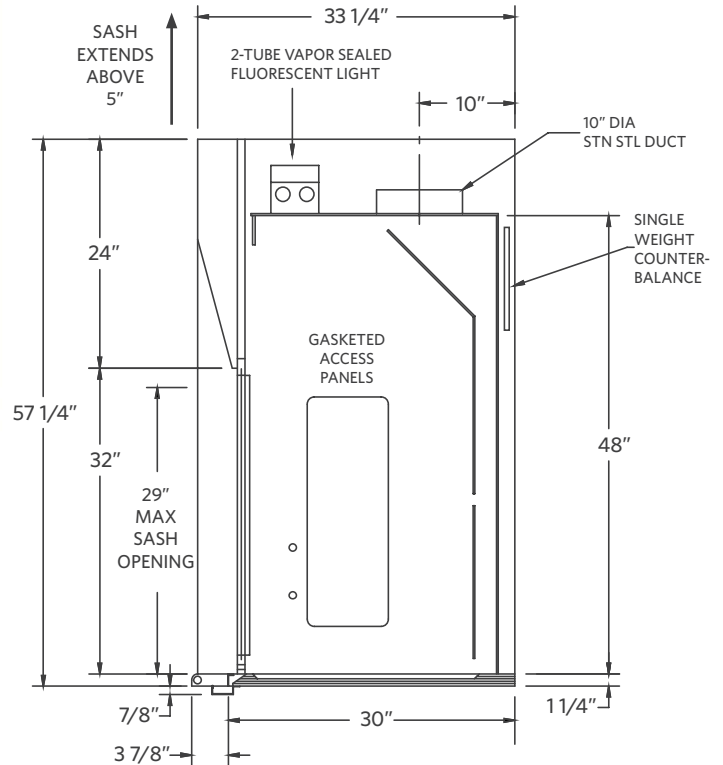

Part Number	Superstructure			Worktop			Hood Opening		CFM @ 29"*	CFM @ 18"*	SP	Blower Model #	Shipping Weight
	W	H	D	W	H	D	W	H					
EH-511-48	48"	56"	33-1/4"	48"	1-1/4"	30"	38"	29"	833	521	.25	BL-500-48	395
EH-511-60	60"	56"	33-1/4"	60"	1-1/4"	30"	50"	29"	1100	688	.34	BL-500-60	450
EH-511-72	72"	56"	33-1/4"	72"	1-1/4"	30"	62"	29"	1367	854	.34	BL-500-72	525
EH-511-96	96"	56"	33-1/4"	96"	1-1/4"	30"	86"	29"	1900	1188	.40	BL-500-96	630

222 S. Main St. 5th Floor, Salt Lake City, UT 84101 | <https://www.mh-usa.com/> | 800-362-4403

The Eliminator 500 Series

The trough assembly is fabricated from chemical-resistant 16-gauge cold rolled steel. ADA kneespace-configured base cabinets, pictured at right, are available. See page 33 for cabinet options.

ELIMINATOR 500 - ADA DESIGN

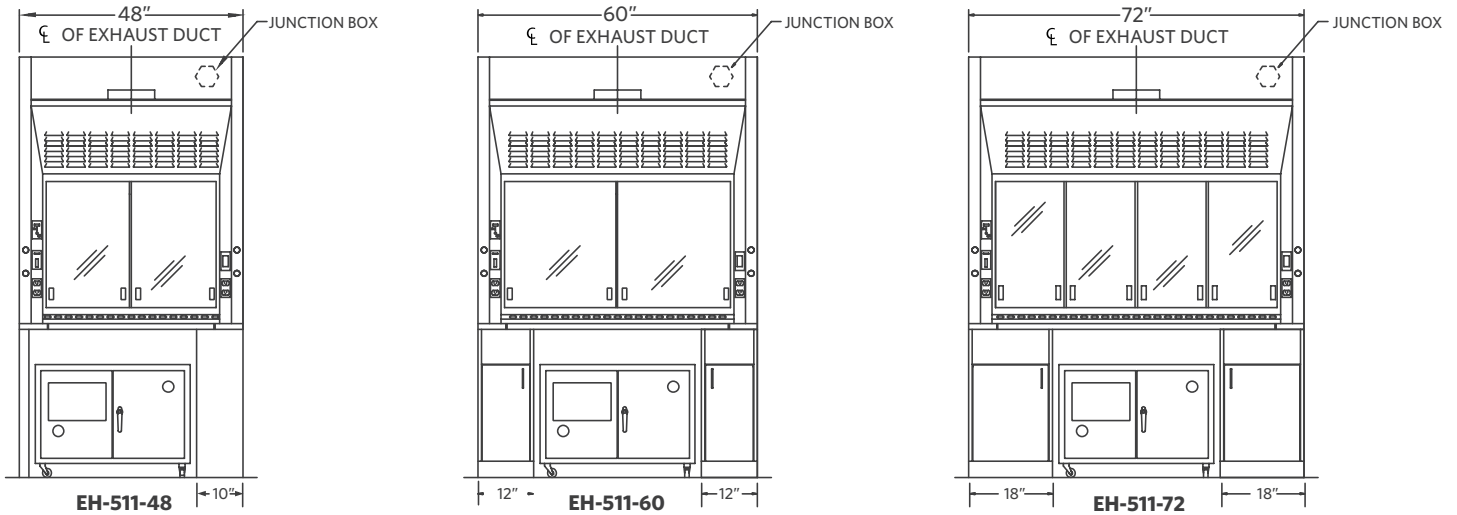

* Optional combination sashes shown in drawings. Base frames and cabinets sold separately.

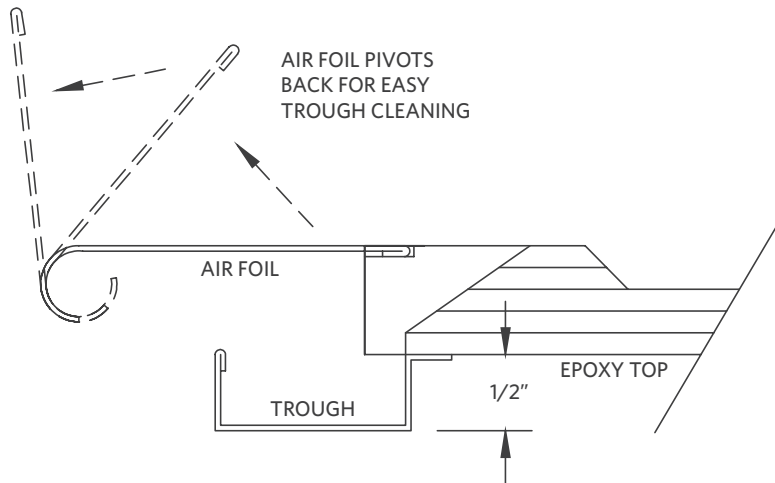

Accessories

ITEM	AMS PT#	PAGE #	ITEM	AMS PT#	PAGE #
Ceiling Enclosures	CE	33	Pre-Wiring	PREW	
Plumbing Accessories		34	Chain and Sprocket Drive	CHNSPK	CALL
Electrical Accessories		35	Stainless Steel Sash	SS SASH	38
Epoxy Tops	ET	39	Stainless Steel Airfoil	SS AF	
Alarms	ALARM	32	Push Button Sash	PUSH BUTTON	38
Base Cabinets	BC	36	Auto Sash Return	AUTO RETURN	38
Roll Out Base	ROB	CALL	Lattice Assembly	LATTICE	CALL
Blowers	BL	CALL	LED Lights	LED	
Pre-Plumbing	PREP		Base Frames and Cabinets		36

The Eliminator 600 Series

The Eliminator 600 Radio Isotope Hood is specifically engineered and built to handle applications involving radiochemicals. It has the same aerodynamic design as the standard airfoil hood, with the added feature of a one-piece stainless steel liner and countertop with radius construction to prevent absorption of radioactive and corrosive chemicals.

ELIMINATOR 600 - RADIO ISOTOPE HOOD

Radio Isotope Hood - For Safe Handling of Radiochemicals.

- Powder coat finish
- Full frame construction
- Shaft drive sash
- T-8 fluorescent light with bulbs
- Flush-mount airfoil
- Interior access to light
- Full-length finger lift
- Louvered front for by-pass
- 304 stainless steel one-piece integral work surface and liner.
- Stainless steel sash
- Stainless steel airfoil



**U.L. 1805
Classified**

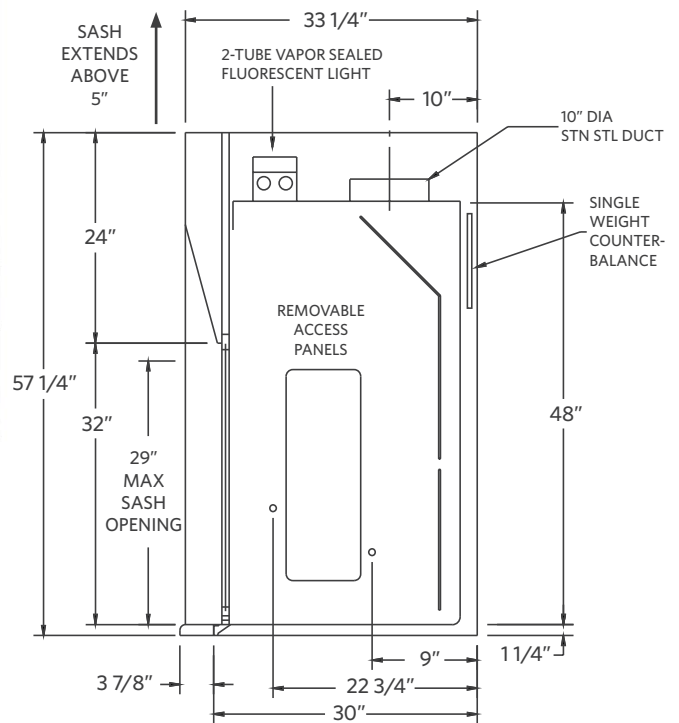

Part Number	Superstructure			Integral Worktop			Hood Opening		CFM @ 29"*	CFM @ 18"*	SP	Blower Model #	Shipping Weight
	W	H	D	W	H	D	W	H					
EH-613-36	36"	56"	33-1/4"	36"	1-1/4"	30"	26"	29"	567	354	.25	BL-600-36	190
EH-613-48	48"	56"	33-1/4"	48"	1-1/4"	30"	38"	29"	833	521	.25	BL-600-48	560
EH-613-60	60"	56"	33-1/4"	60"	1-1/4"	30"	50"	29"	1100	688	.34	BL-600-60	675
EH-613-72	72"	56"	33-1/4"	72"	1-1/4"	30"	62"	29"	1367	854	.34	BL-600-72	790
EH-613-96	96"	56"	33-1/4"	96"	1-1/4"	30"	86"	29"	1900	1188	.40	BL-600-96	1025

The Eliminator 600 Series

The interior of the hood and integral countertop are fabricated of 304 stainless steel, buffed and polished to a smooth #4 finish. This reduces the chance of chemical buildup and simplifies decontamination. The flush-mount radiused airfoil is also type 304 stainless steel, as is the standard vertical rising sash. A combination sash is available as an option. Five available sizes and many optional accessories meet all your design needs and the end user's application requirements.

ELIMINATOR 600 - RADIO ISOTOPE HOOD

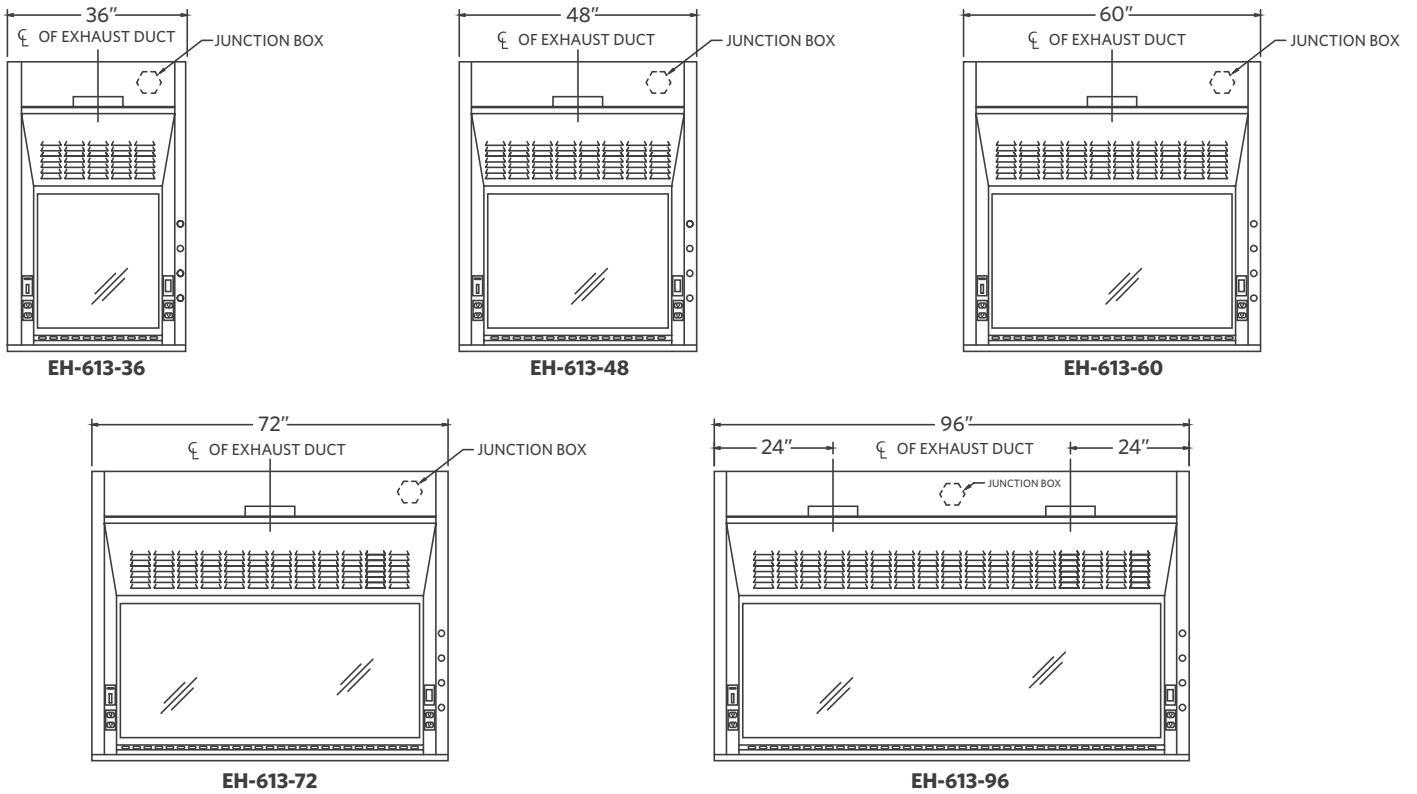

Accessories

ITEM	AMS PT#	PAGE #	ITEM	AMS PT#	PAGE #
Ceiling Enclosures	CE	33	Pre-Wiring	PREW	
Plumbing Accessories		34	Sash Stops	SASHSTOP	38
Electrical Accessories		35	Chain and Sprocket Drive	CHNSPK	CALL
Alarms	ALARM	32	Push Button Sash	PUSH BUTTON	38
Base Cabinets	BC	36	Combination Sash	H&V	38
Blowers	BL	CALL	Lattice Assembly	LATTICE	CALL
Pre-Plumbing	PREP		Auto Sash Return	AUTO RETURN	38

The Eliminator 700 Series

The Eliminator 700 Perchloric Acid Hood has the same aerodynamic design as the 100 series, with a 45-degree angle around the fascia and a flush-mount radiused airfoil across the bottom to minimize turbulence and provide increased performance.

ELIMINATOR 700 - PERCHLORIC ACID HOOD

Perchloric Acid Hood - For Safe Handling of Perchloric Acid



**U.L. 1805
Classified**

- Powder coat finish
- Full frame construction
- Shaft drive sash
- T-8 fluorescent light with bulbs
- Flush-mount airfoil
- Full-length finger lift
- Louvered front for by-pass
- 316 stainless steel one-piece integral work surface and liner.
- Built-in trough
- Manual washdown
- Stainless steel sash
- Stainless steel airfoil

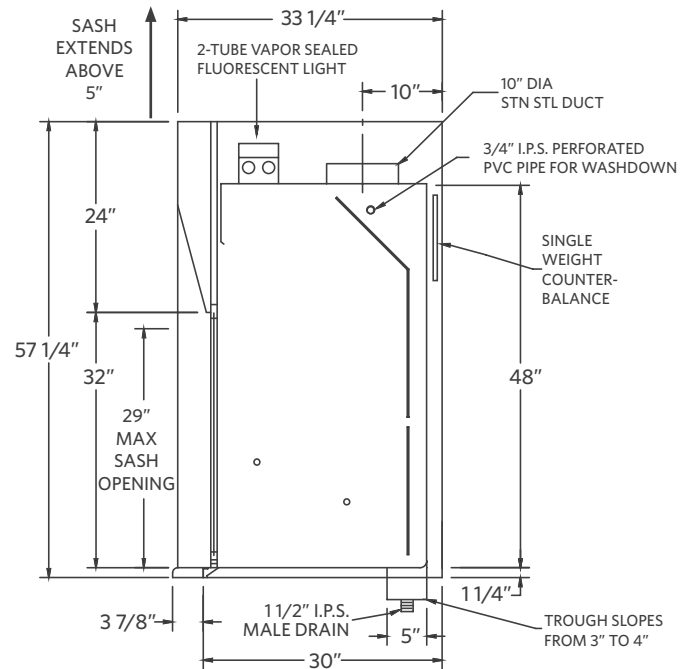

Part Number	Superstructure			Integral Worktop			Hood Opening		CFM @ 29"*	CFM @ 18"*	SP	Blower Model #	Shipping Weight
	W	H	D	W	H	D	W	H					
EH-716-36	36"	56"	33-1/4"	36"	1-1/4"	30"	26"	29"	567	354	.25	BL-700-36	190
EH-716-48	48"	56"	33-1/4"	48"	1-1/4"	30"	38"	29"	833	521	.33	BL-700-48	560
EH-716-60	60"	56"	33-1/4"	60"	1-1/4"	30"	50"	29"	1100	688	.34	BL-700-60	675
EH-716-72	72"	56"	33-1/4"	72"	1-1/4"	30"	62"	29"	1367	854	.34	BL-700-72	790
EH-716-96	96"	56"	33-1/4"	96"	1-1/4"	30"	86"	29"	1900	1188	.40	BL-700-96	1025

The Eliminator 700 Series

This hard-working hood also features a built-in trough to capture runoff in washdown procedures where perchloric acid is in use. In addition, there is a manual washdown feature for the areas behind the baffles as well as the duct-collar areas. The interior is fabricated of type 316 stainless steel, integrally welded to a 316 stainless steel work surface, then buffed and polished to a #4 finish. The top is 1-1/4" with a 1/4" dish to retain spills. The airfoil and sash are also made of 316 stainless steel.

The EH-700 is built tough to withstand the daily use of perchloric acid, while keeping the workplace safe.

ELIMINATOR 700 - PERCHLORIC ACID HOOD

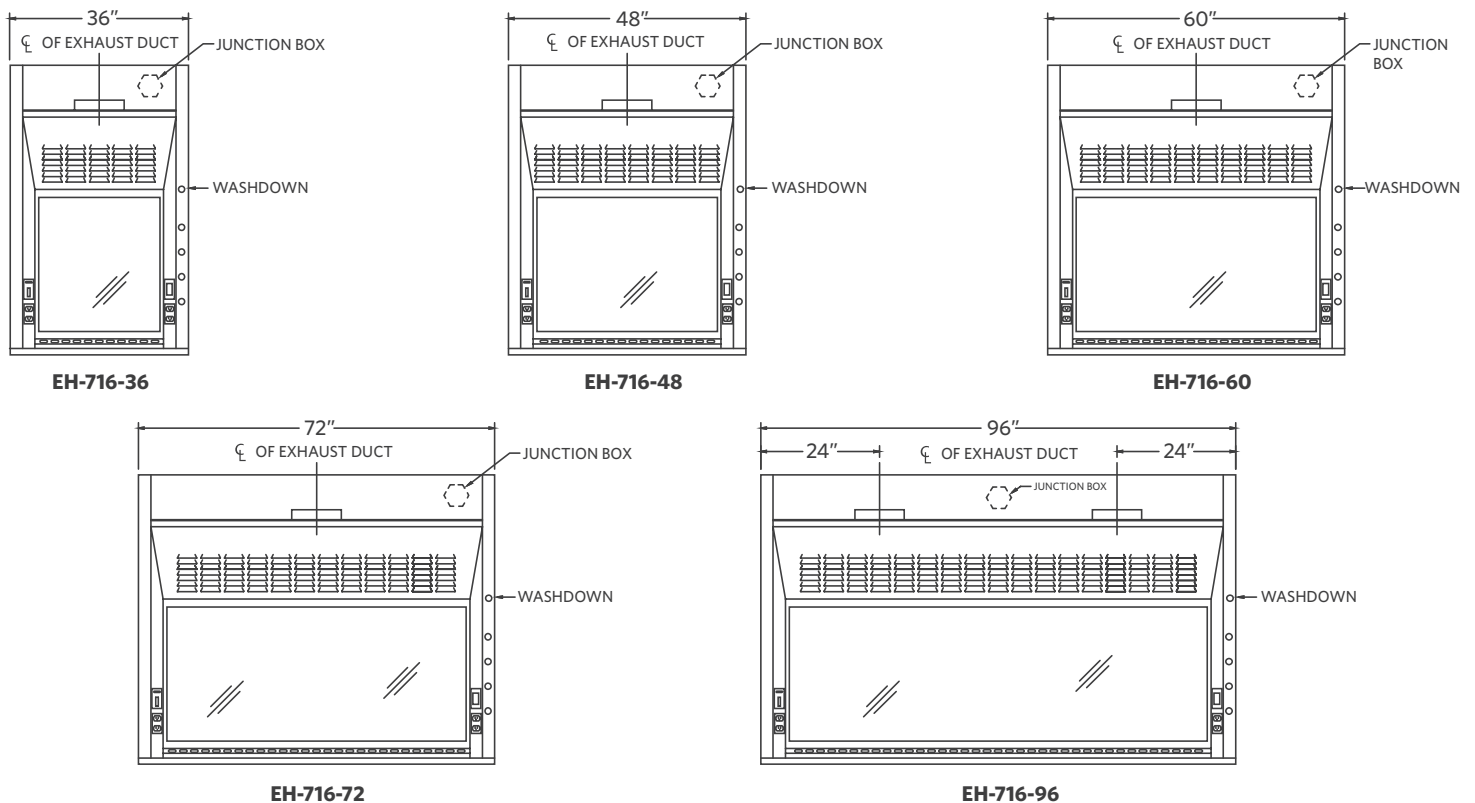

Accessories

ITEM	AMS PT#	PAGE #	ITEM	AMS PT#	PAGE #
Ceiling Enclosures	CE	33	Pre-Wiring	PREW	
Plumbing Accessories		34	Sash Stops	SASHSTOP	38
Electrical Accessories		35	Chain and Sprocket Drive	CHNSPK	CALL
Alarms	ALARM	32	Push Button Sash	PUSH BUTTON	38
Base Cabinets	BC	36	Combination Sash	H&V	38
Blowers	BL	CALL	Lattice Assembly	LATTICE	CALL
Pre-Plumbing	PREP		Auto Sash Return	AUTO RETURN	38

The Eliminator 800 Series

A basic fume hood for K-12 educational applications, the EH-800 series is similar in design and construction to the EH-300 (Thin Wall) hood, but with 5" (127 mm) posts to provide plumbing and electrical fixtures on the face of the hood. This hood has many of the same features found in other AMS hoods, but it is economically priced for secondary school budgets.

ELIMINATOR 800 - FLAT FRONT

Flat Front - Economical School Hood

- Powder coat finish
- Full frame construction
- Shaft drive sash
- U.L. listed poly resin liner
- T-8 fluorescent light with bulbs
- Knock down capability
- Full-length finger lift
- Louvered front for by-pass
- 10" round S/S duct collar



**U.L. 1805
Classified**

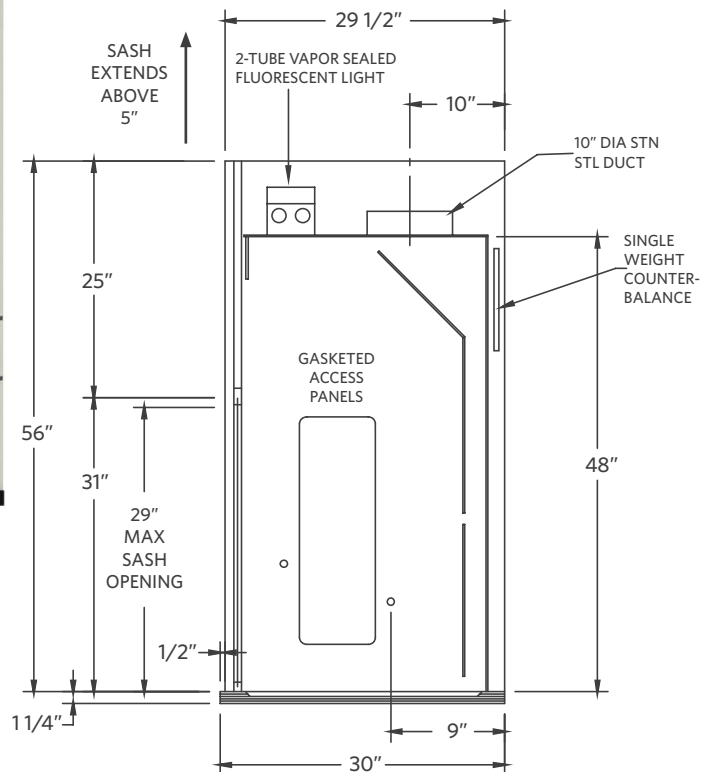

Part Number	Superstructure			Worktop			Hood Opening		CFM @ 29"*	CFM @ 18"*	SP	Blower Model #	Shipping Weight
	W	H	D	W	H	D	W	H					
EH-811-36	36"	56"	29-1/2"	36"	1-1/4"	30"	26"	29"	567	354	.25	BL-100-36	300
EH-811-48	48"	56"	29-1/2"	48"	1-1/4"	30"	38"	29"	833	521	.33	BL-100-48	360
EH-811-60	60"	56"	29-1/2"	60"	1-1/4"	30"	50"	29"	1100	688	.34	BL-100-60	440
EH-811-72	72"	56"	29-1/2"	72"	1-1/4"	30"	62"	29"	1367	854	.34	BL-100-72	520
EH-811-96	96"	56"	29-1/2"	96"	1-1/4"	30"	86"	29"	1900	1188	.40	BL-100-96	680

The Eliminator 800 Series

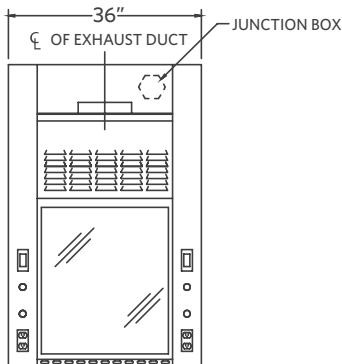

EH-811-36

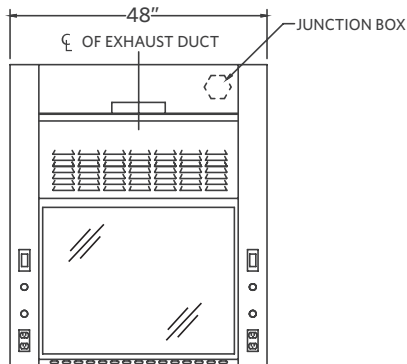

EH-811-48

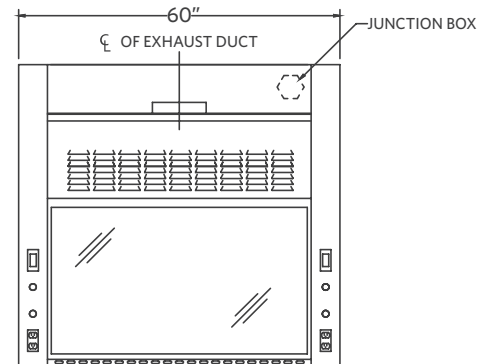

EH-811-60

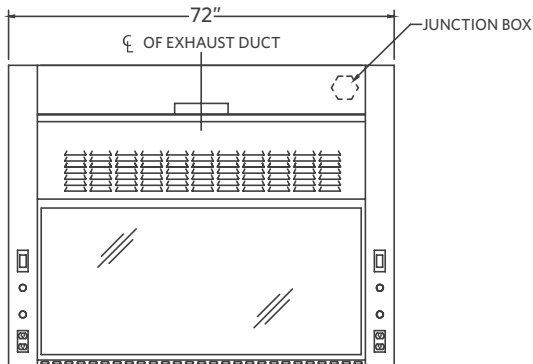

EH-811-72

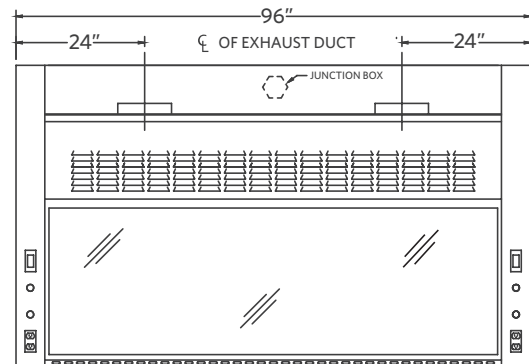

EH-811-96

Accessories

ITEM	AMS PT#	PAGE #	ITEM	AMS PT#	PAGE #
Ceiling Enclosures	CE	33	Pre-Wiring	PREW	
Plumbing Accessories		34	Sash Stops	SASHSTOP	38
Electrical Accessories		35	Chain and Sprocket Drive	CHNSPK	CALL
Epoxy Tops	ET	39	Stainless Steel Sash	SS SASH	38
Alarms	ALARM	32	Push Button Sash	PUSH BUTTON	38
Base Cabinets	BC	36	Combination Sash	H&V	38
Blowers	BL	CALL	Auto Sash Return	AUTO RETURN	38
Pre-Plumbing	PREP		Lattice Assembly	LATTICE	CALL

The Eliminator 900 Series

The EH-900 series is an educational viewing fume hood with one slimmed down (2" or 51 mm) front post and one standard (5" or 127 mm) post to allow for more workspace and electrical services. Plumbing service must be deck mounted.

The EH-900 is available in either right-hand or left-hand orientation. This hood features a two-sash configuration and a third (end) viewing window, making it ideal for use in high schools or any environment where demonstration of experiments is desired. The end window may be eliminated for through-wall installations.

ELIMINATOR 900 - DEMONSTRATION HOOD

Demonstration Hood- Three Windows for Optimum Viewing

- Powder coat finish
- Full frame construction
- U.L. listed poly resin liner
- T-8 fluorescent light with bulbs
- Knock down capability
- Full-length finger lift
- Louvered front for by-pass
- 10" round S/S duct collar
- Sash interlock



**U.L. 1805
Classified**

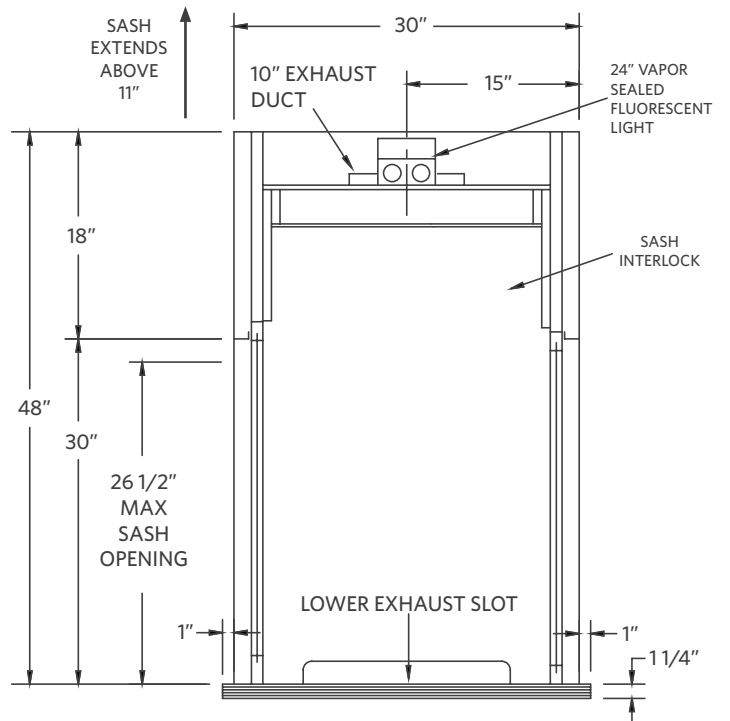

Part Number	Superstructure			Worktop			Hood Opening		CFM @ 26.5"*	CFM @ 18"*	SP	Blower Model #	Shipping Weight
	W	H	D	W	H	D	W	H					
EH-911-60	60"	48"	30"	60"	1-1/4"	32"	53"	26.5"***	1030	722	.75	BL-900-60	500

The Eliminator 900 Series

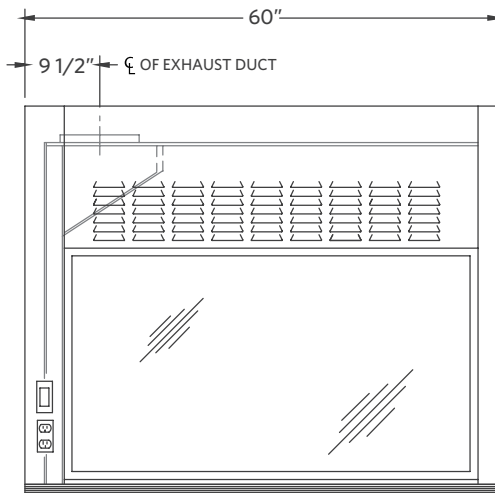

EH-911-60L (switches on left as shown)
EH-911-60R (switches on right; not shown)

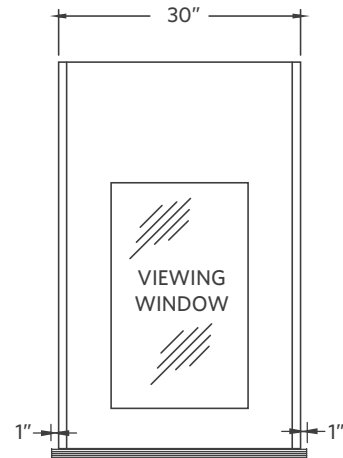

To order without a viewing window, please add -OEW to the part number

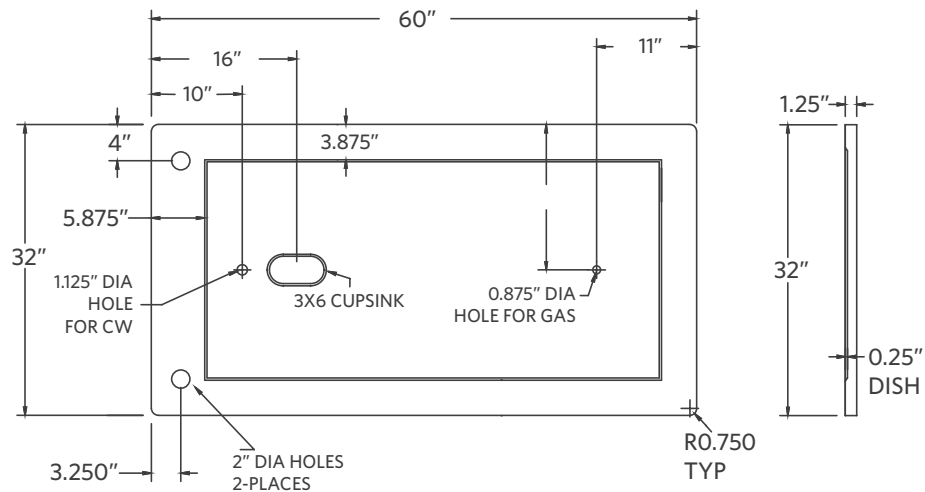

Accessories

ITEM	AMS PT#	PAGE #	ITEM	AMS PT#	PAGE #
Ceiling Enclosures	CE	33	Pre-Wiring	PREW	
Plumbing Accessories		34	Sash Stops	SASHSTOP	38
Electrical Accessories		35	Stainless Steel Sash	SS SASH	38
Epoxy Tops	ET	39	Push Button Sash	PUSH BUTTON	38
Alarms	ALARM	32	Combination Sash	H&V	38
Base Cabinets	BC	36	Auto Sash Return	AUTO RETURN	38
Blowers	BL	CALL	Lattice Assembly	LATTICE	CALL
Pre-Plumbing	PREP				

The Eliminator Paint (Spray) Booth

The AMS Paint Booth is fabricated of 18-gauge steel with a corrosion resistant, powder coat baked epoxy finish. The upper booth enclosure includes a standard vapor-proof light as well as two filters set in an easy-to-change flange bracket system. The globed interior light is mounted with bulb included.

ELIMINATOR PAINT (SPRAY) BOOTH

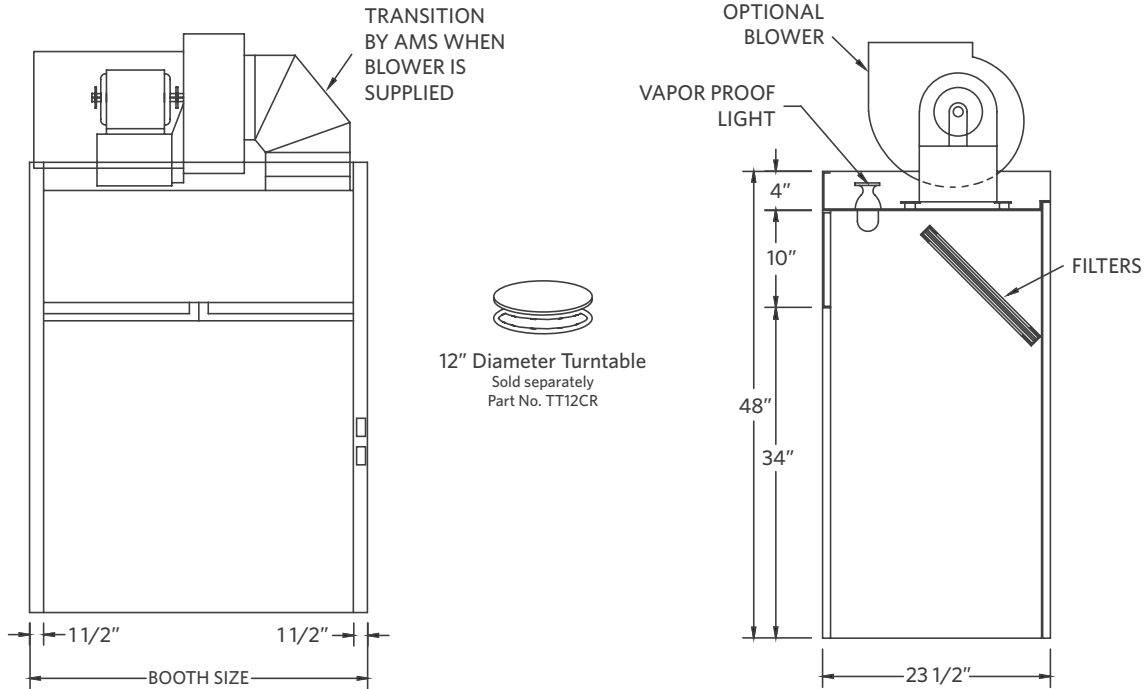

Paint (Spray) Booth

Part Number	Description	CFM @ 100 FPM
AMS-24-PB	24" Paint (Spray) Booth	472
AMS-30-PB	30" Paint (Spray) Booth	613
AMS-36-PB	36" Paint (Spray) Booth	755
AMS-48-PB	48" Paint (Spray) Booth	1040
AMS-60-PB	60" Paint (Spray) Booth	1322

Explosion-Proof Options

Part Number	Description	CFM @ 100 FPM
AMS-24-XPB	24" Booth w/X-P Light	472
AMS-30-XPB	30" Booth w/X-P Light	613
AMS-36-XPB	36" Booth w/X-P Light	755
AMS-48-XPB	48" Booth w/X-P Light	1040
AMS-60-XPB	60" Booth w/X-P Light	1322

Paint (Spray) Booth w/ Blower

Part Number	Description	CFM @ 100 FPM
AMS-24-PBW	24" Booth and Blower	472
AMS-30-PBW	30" Booth and Blower	613
AMS-36-PBW	36" Booth and Blower	755
AMS-48-PBW	48" Booth and Blower	1040
AMS-60-PBW	60" Booth and Blower	1322

Paint (Spray) Booth w/ Explosion-Proof Light/Blower

Part Number	Description	CFM @ 100 FPM
AMS-24-XPBW	24" Booth w/X-P Light and Blower	472
AMS-30-XPBW	30" Booth w/X-P Light and Blower	613
AMS-36-XPBW	36" Booth w/X-P Light and Blower	755
AMS-48-XPBW	48" Booth w/X-P Light and Blower	1040
AMS-60-XPBW	60" Booth w/X-P Light and Blower	1322

The Eliminator Paint (Spray) Booth

The optional blower motor operates at an RPM designed to provide 100 LFM and approximately 3/4" of static pressure. If the blower is ordered, it will be mounted on the booth and wired to the common junction box with the light. The transition piece from the booth to blower will be provided and connected. Both the light and the blower can be pre-wired to switches in the front post area of the booth when required.

ELIMINATOR PAINT (SPRAY) BOOTH

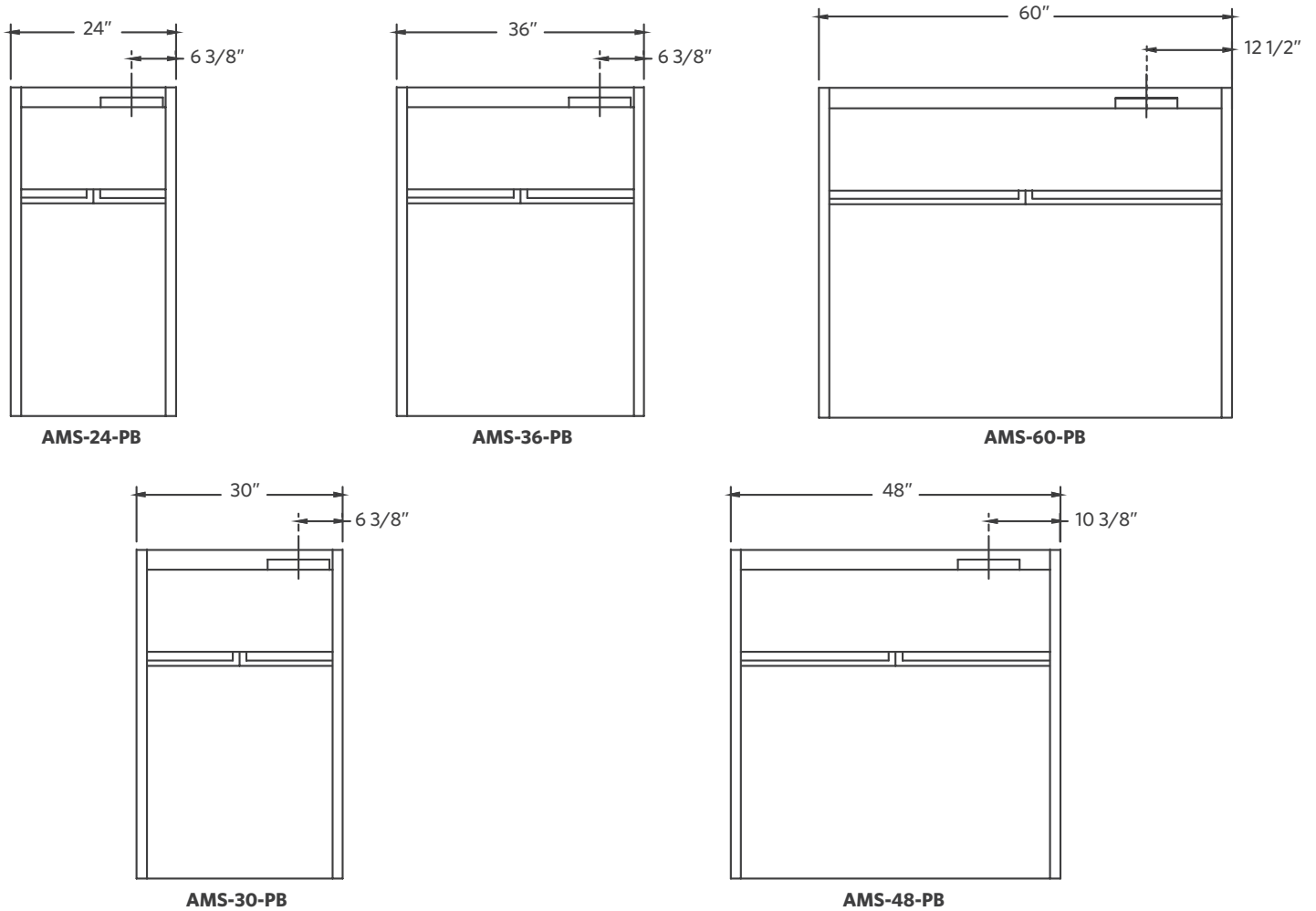

NOTE: Explosion-proof (X-P) switches must mount on the exterior of booth or be shipped loose for remote operation.

Accessories

ITEM	AMS PT#	PAGE #	ITEM	AMS PT#	PAGE #
Light Switch	LTSW	35	Galvanized Top		CALL
Blower Switch	BLSW	35	Pre-Wire Service	PREWIRE	
Stainless Steel Top		39			

Portable Hoods

This AMS hood is portable, but must be connected to an HVAC system. The backward-curved 120 volt blower has a variable speed control to maximize efficiency and minimize motor noise. The blower unit sits atop a fully welded tube chamber with plexiglas windows for viewing from all four sides. The front has a fold-up door to allow for loading and unloading of apparatus and experiments.

PORTABLE HOODS

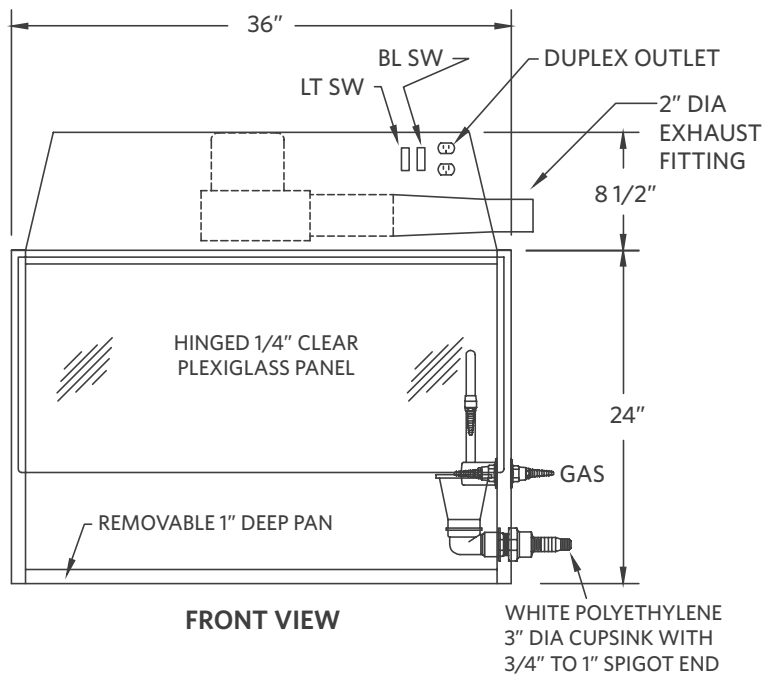

Part Number	Description
AMS-36-CRPH	Hood Only
AMS-36-CRPHT	Hood with Epoxy Top
AMS-36-CRPHTC	Hood with Epoxy Top & Cart

*For Stainless Steel Construction use the prefix -SS

Portable Hood Adapter Option

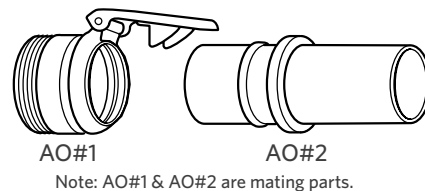

- Painted steel construction
- Energy-saving LED light fixture
- Combination light/blower switch
- GFI duplex outlet
- Pre-wired
- 8' Power Cord
- 2" dia. x 48" flex exhaust duct.

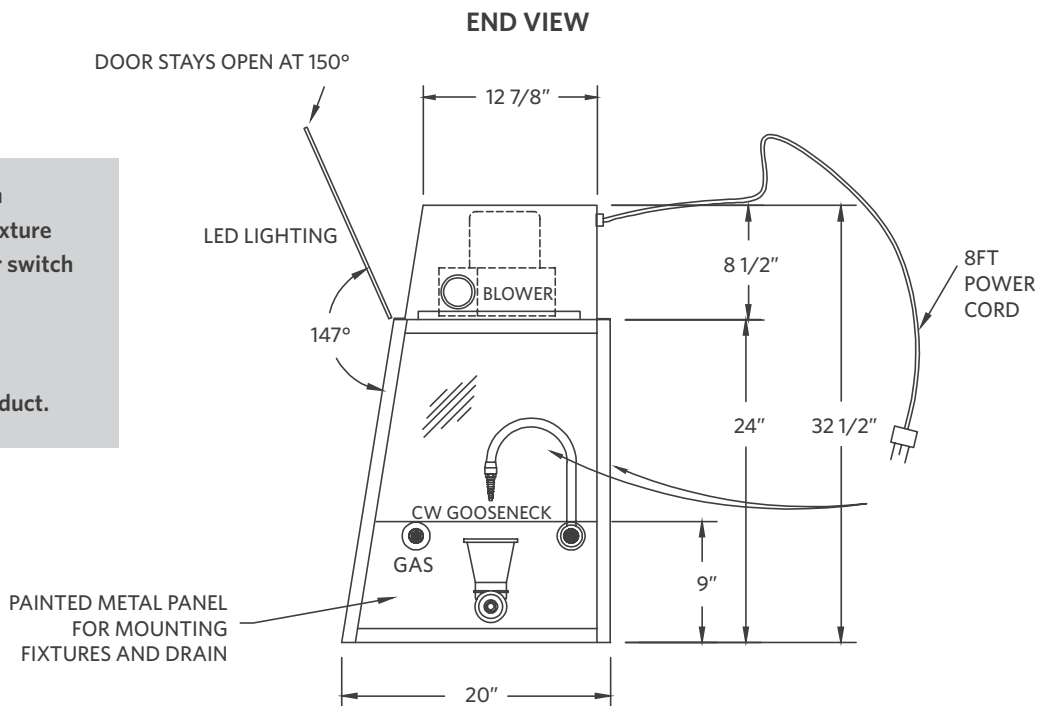

Canopy Hoods

AMS canopy hoods are designed to collect and exhaust heat, steam and odors when mounted above hot plates, water baths or portable equipment. They are available in three different models as pictured here and in six standard widths: 24", 30", 36", 48", 60", and 72". Custom sizes are also available.

Standard canopy hoods are available in 18-gauge cold rolled steel, finished with acid wash and powder coat epoxy paint. (See inside back cover for available standard colors.) Stainless canopy hoods are fabricated of 18-gauge 304 stainless steel with a #4 smooth grain finish. Two stainless steel threaded rods come with FS and SE models; four are supplied with IL models.

CANOPY HOODS

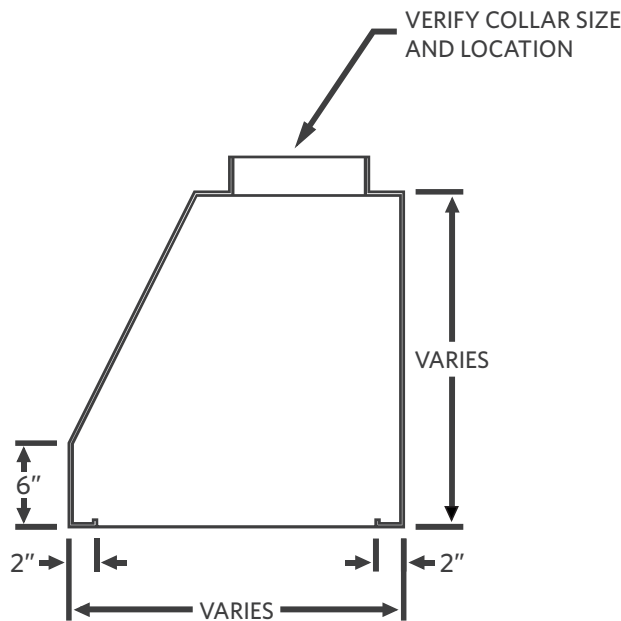

Ordering Canopy Hoods:

Part Number	Description
CH-FS	Flat back & flat sides
CH-IL	Center style
CH-SE	Flat back and sloped sides

*For Stainless Steel Construction use the prefix -SS

Example:

Flat Back & Sides Depth
CH-FS-4824-SS
 Width Stainless Steel

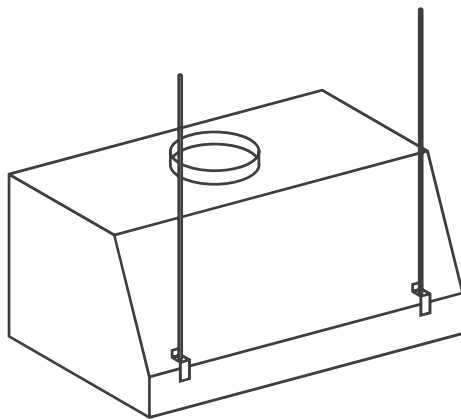

CANOPY HOOD w/
FLAT BACK & FLAT SIDES - "FS" STYLE

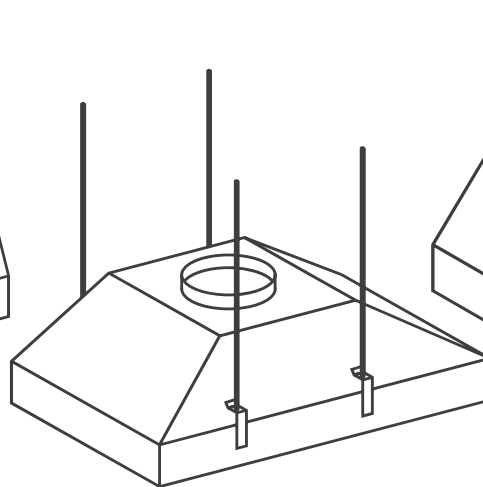

CENTER CANOPY HOOD - ISLAND "IL" STYLE

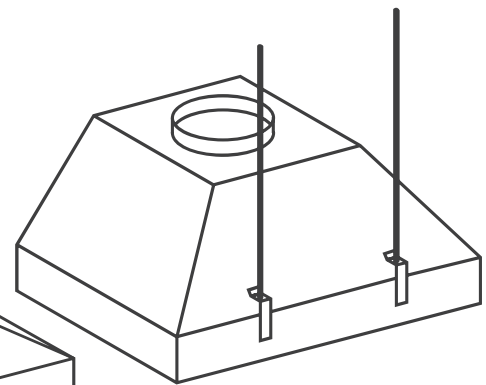

CANOPY HOOD - "SE" STYLE

Updraft/Downdraft Hoods

Inexpensive hoods designed to increase operator safety by ridding fumes such as formalin, smoke or any other non-hazardous media. Many sizes are available; please contact your Air Master Systems representative for further information.

SINGLE-SIDED DOWNDRAFT HOOD

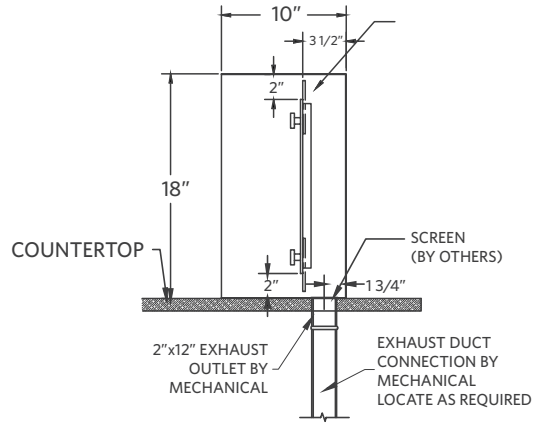
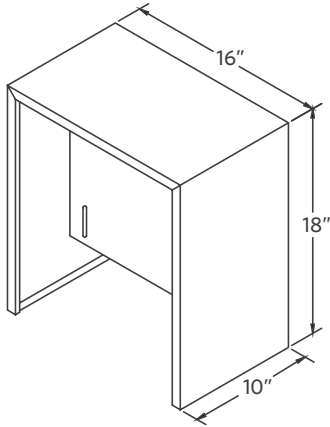

DOUBLE-SIDED DOWNDRAFT HOOD

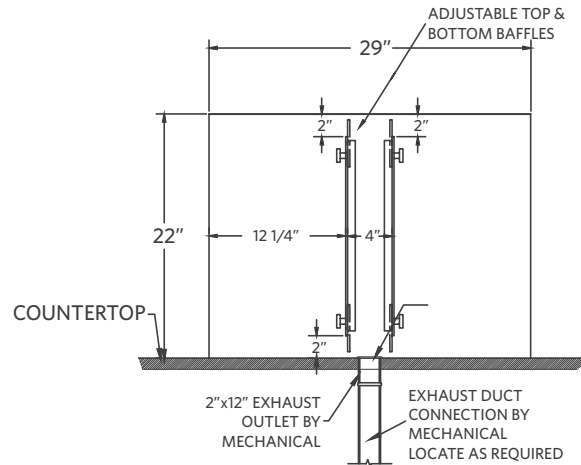
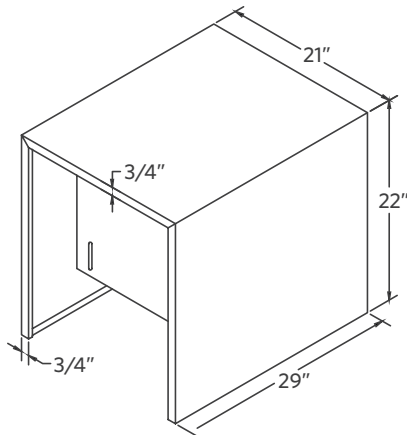

SINGLE-SIDED UPDRAFT HOOD

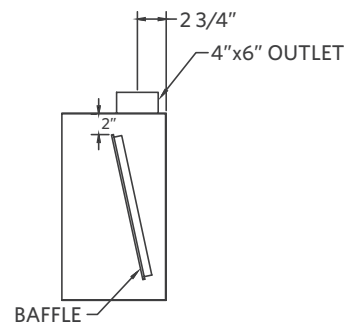
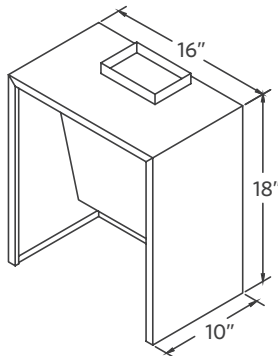

Air Monitor Alarms

AFA 500 MK3 FUME HOOD AIRFLOW MONITOR



Alarm Range	30-400 fpm (.15 - 2.0 m/s)
Accuracy	Face velocity accuracy +/- 10%
Airflow Sensor	On-board or remote sensor
Calibration	Single or 2-point (Installer Selectable)
Low Air Alarm Delay	Fixed 5 seconds
Relay Output	1 --(Low Air Alarm)
Analog Output	Not Available
Relay Input	2 - Night setback and sash high
Comm. Port	RS232 - Can be connected via serial interface to LAN network (Full hood performance software reporting available)
Sash Height Indication	Yes - using a micro switch or Proximity switch input. With repeat alarm feature factory set to 5 minutes. (Can be adjusted via laptop up to 30 min.)
Night Setback	Yes - using a relay input
External Alarm Indication	Not available
Power Requirement	Input - 120VAC, 60Hz / Output - 15VDC, 500ma
Display - Visual	LED: red, alarm; green, normal
Alarm Indication	Red LED and audible alarm
Horn Silence	Yes - temporary
Mounting	Semi Flush
Operating Temperature	55-86 F (13-30 C)
Storage Temperature	-40-150 F (-40-65 C)
Instrument Dimensions	Instrument Case: 5.2" H x 3.19" W x 1.97" D (132mm H x 81mm W x 50mm D)
Agency Listings	UL and CE

AFA 1000/1 MK3 FUME HOOD AIRFLOW MONITOR



Display Range	0-999 fpm (0 - 5.0 m/s)
Alarm Range	0-999 fpm (0 - 5.0 m/s)
Field Set-Up	2-point velocity calibration (with on-screen instructions)
Accuracy	Sensor / Display Resolution 1 fpm / Face Velocity Accuracy +/-10%
Alarm Delays	User Configurable - 0 to 60 seconds
Relay Output	4 (1 on board - 3 on optional plug in relay interface unit)
Analog Output	0-10V Output, Directly proportional to velocity (Optional)
Relay Input	3
Comm. Port	RS232 - Can be connected via Serial Interface to LAN network (Full Software Available)
Sash High Indication	Yes, with separate plug-in connection
Night Setback	Yes
External Alarm Indication	Yes
Power Requirement	Input-120VAC, 60Hz
Units	Output-15VDC, 500ma
Display-Visual	English and Metric (user selectable)
Alarm Indication	Analog bar graph or Fault Timeline / LEDs: red, alarm; yellow, caution; green, normal / Digital display of velocity reading (can be turned off)
Horn Silence	Yes (temporary / permanent / automatic depending on type of alarm or external input)
Mounting	Semi Flush
Operating Temperature	55-86 F (13-30 C)
Storage Temperature	-40-150 F (-40-65 C)
Instrument Dimensions	Instrument Case: 5.2" H x 3.19" W x 1.14" D (132mm H x 81mm W x 29mm D)
Agency Listings	UL and CE

Ceiling Enclosures & Finished Backs

Air Master Systems Corporation offers ceiling enclosures and finished backs to provide a professional, finished design in any setting. Ceiling enclosures and finished backs are fabricated of cold rolled steel and finished to match the fume hood superstructure.

CEILING ENCLOSURES

The ceiling enclosures are available in two types: for standard fume hoods and also for those fume hoods utilizing the optional Air Chamber. Both enclosures conceal and protect the hood ductwork, electrical conduit and other supply lines.

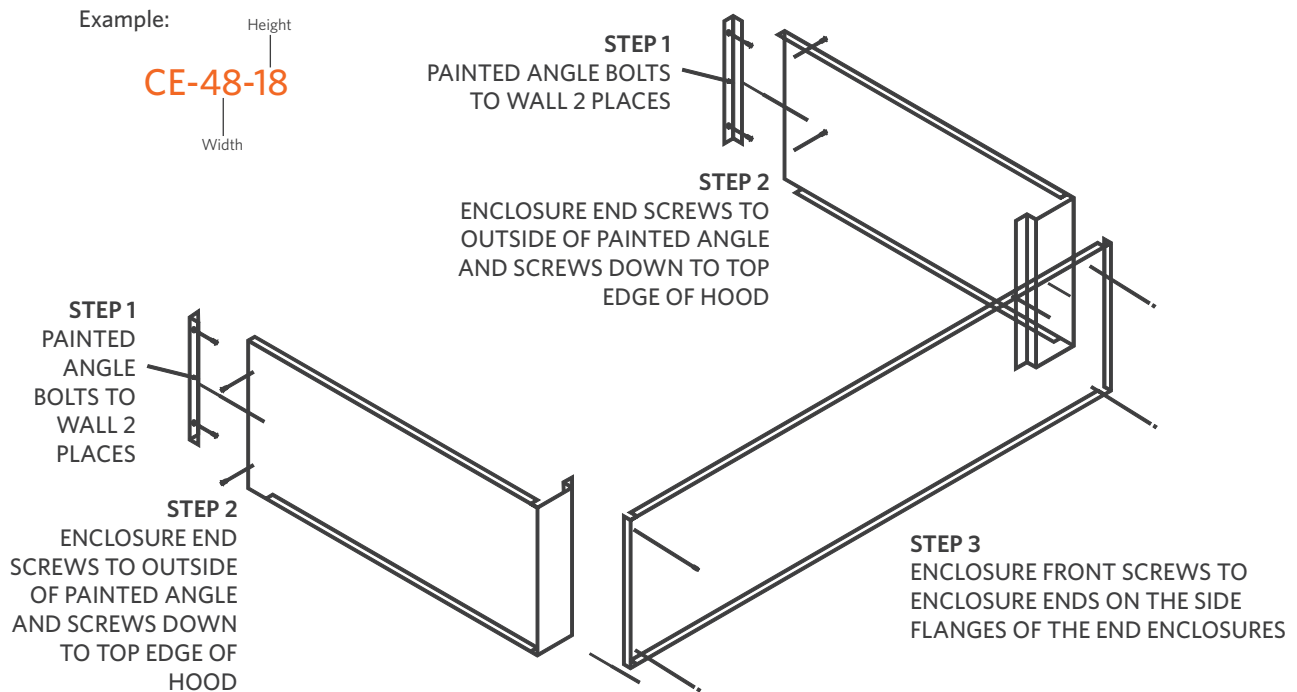

FINISHED BACKS

Finished backs are used to close off the back of the fume hood, giving it a finished look when located in the center of a room.

Example:

FINBACK-48

Width

Plumbing Accessories

All Air Master Systems Corporation remote-operated fixtures come standard with four-prong handles, baked color-coded epoxy upper assemblies and control rods cut to length. Chrome and other styles are available upon request. Preplumbed services are 3/8"OD-1/4"ID polypropylene tubing for water, air and vacuum; 1/2"OD flexible stainless steel tubing for burning gas services.

PLUMBING ACCESSORIES

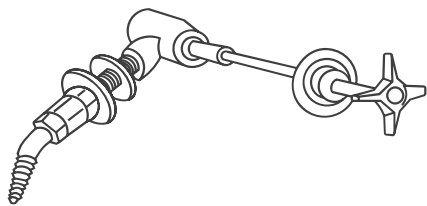

Remote Control Fixtures

Part Number	Description
FXTGAS	Gas
FXTAIR	Air
FXTVAC	Vacuum
FXTNIT	Nitrogen
FXTCW	Cold Water

*Others available upon request

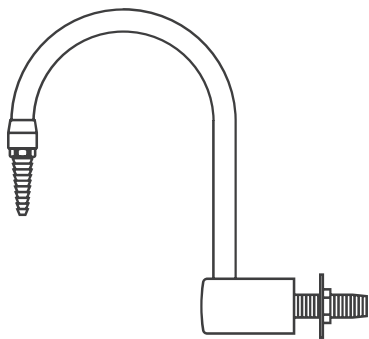

Gooseneck Faucet
Part # FXTGN
Specify Hot or Cold

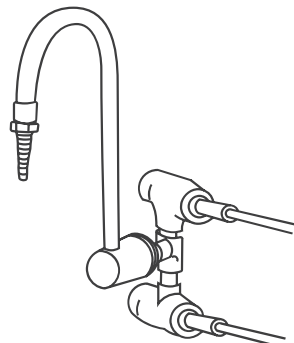

Hot and Cold Water Mixing
Part # FXTCWM

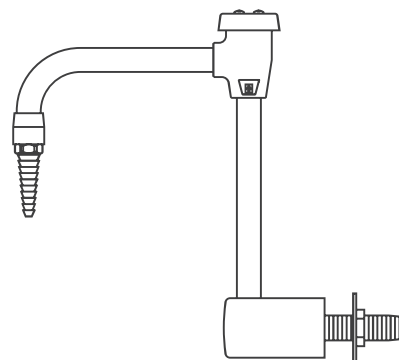

Gooseneck Faucet with Vacuum Breaker
Part # FXTGNWVB
Specify Hot or Cold

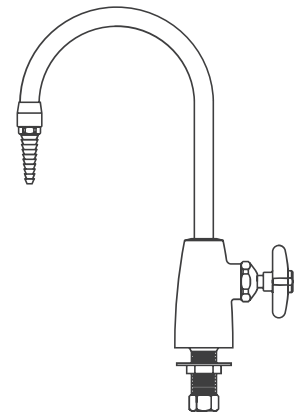

Deck Mount Water
Part # FXTDMW

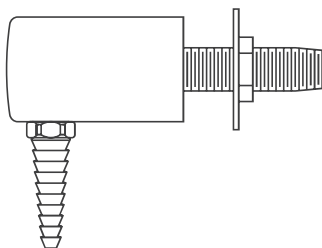

90° Water Faucet
Part # FXTDS

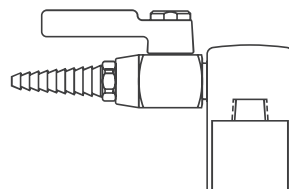

Deck Mount Gas Single Outlet
Part # FXTDMG1

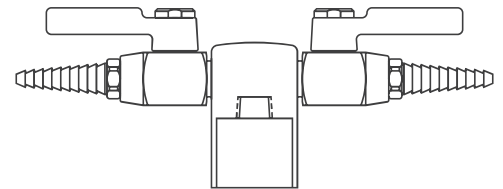

Deck Mount Gas Double Outlet
Part # FXTDMG2

Electrical Accessories & Specifications

Pre-Wire service is completed in accordance with NEC and UL-1805 standards

Note: If the fume hood is not pre-wired, wiring in the field must be accomplished using UL listed electrical fixtures while observing NEC standards and local electrical codes.

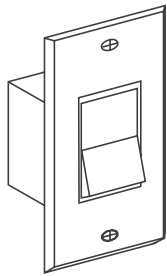
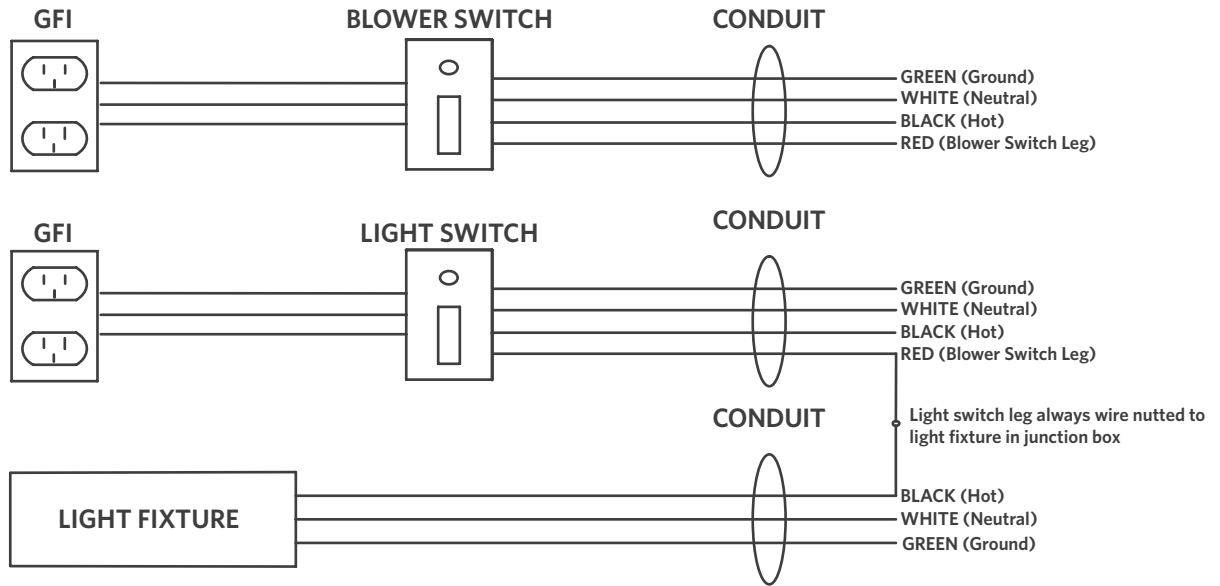

**Single Pole
15 Amp Light Switch**
Standard Black Color
and Cover Plate
Part # LSW

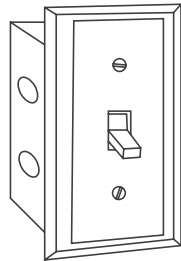

**Red Illuminated
Toggle Switch**
with Black Cover Plate
Part # BLSW

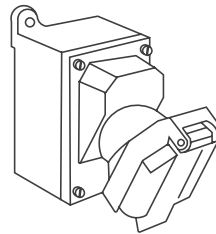

Explosion Proof Outlet
Class 1, Group 1
Part # XPO

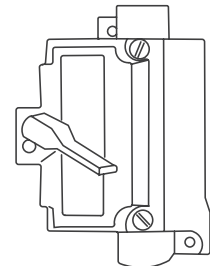

Explosion Proof Switch
Class 1, Group 1
Part # XSW

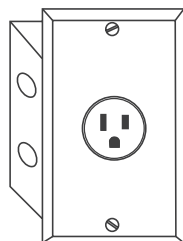

**208 Volt, 20 Amp
Single Pole Receptacle**
230, 277 or other
available upon request
Part # 208

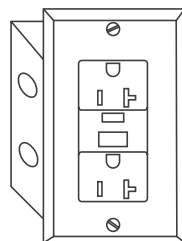

**120 Volt, 20 Amp Ground Fault
Interrupter (GFI)**
Duplex Outlet
Standard Black color with cover
Part # GFI



Explosion Proof Light
Class 1, Group 1
Available in
Incandescent or fluorescent
Part # XPL

Base Cabinets

Although AMS is your fume hood expert, we do offer a selection of inset metal wall and base cabinets in 29", 32" and 35" heights. When a large quantity of standard laboratory cabinets is required, please contact us for an approved distributor.

AMS fume hood base cabinets conform to the method of testing and performance requirements set forth in the Scientific Equipment Furniture Association (SEFA). All ADA and hood base cabinets can be manufactured in stainless steel.



SB3512-100R



SB3212-100R



SB2912-100R

*For a wider variety of configurations, part numbers, and sizes, refer to Air Master Systems Casework Catalog.

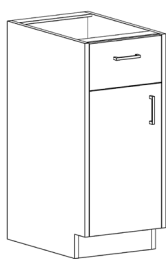

Flammable, Acid, Vacuum Cabinets

The Flammable Liquid Storage Cabinet is a “cabinet-within-a-cabinet” design with fully welded 18ga interior and exterior units. Both cabinets are completely powder coated inside and out, offering greater protection against corrosion than the standard double panel construction. This design creates a 1.5” airspace on all four sides as well as top and bottom for heat resistance up to 2400 degrees F.

The interior of the cabinet contains one fully adjustable shelf and a 2” deep removable drip pan to capture any spills or leaks inside the cabinet. Exterior depth of the cabinet is 18” and interior depth is 14”. A 2” x 2” 12ga support angle is shipped with each cabinet for countertop installation.

FLAMMABLE STORAGE CABINET

Flammable storage cabinets can be painted any standard color or safety yellow. For synchronized self-closing doors, add -SCC to the part number. For 22” deep, replace -200 with -220. For mobile cabinets, contact your AMS representative.

height depth vent kit
SFSB3518-22R-VK
width right hinge



SFSB2930-18

*For more part numbers and sizes, refer to Air Master Systems Casework Catalog.

ACID STORAGE CABINET

Acid cabinet can be painted any standard color or safety blue. Add Suffix “VK” if Vent Kit is required.

height depth vent kit
SASB3518-22R-VK
width right hinge



SASB3530-18

*For more part numbers and sizes, refer to Air Master Systems Casework Catalog.

Flammable, Acid, Vacuum Cabinets

Doors have a continuous hinge and lever type handles with a hidden 3-point lock mechanism. If a self-closing feature is required, a hydraulic closure will be attached to the doors and a custom closing system attached to the interior cabinet. The back of the cabinet has two venting holes that are plugged with 2" barrel bungs.

AMS Flammable Liquid Storage Cabinets are constructed in accordance with OSHA and NFPA 30, and are UL listed.

VACUUM PUMP CABINET

Additional insulation materials for noise reduction available upon request.



SB2930-20V

*For more part numbers and sizes, refer to Air Master Systems Casework Catalog.

HOOD BASE FRAMES



Left Hand Side Chase
(HBF-3248-LH shown)

Height	Part Number
30"	HBF-3048-LH
32"	HBF-3248-LH
35"	HBF-3548-LH



Right Hand Side Chase
(HBF-3248-RH shown)

Height	Part Number
30"	HBF-3048-RH
32"	HBF-3248-RH
35"	HBF-3548-RH



No Side Chase
(HBF-3248-NC shown)

Height	Part Number
30"	HBF-3048-NC
32"	HBF-3248-NC
35"	HBF-3548-NC

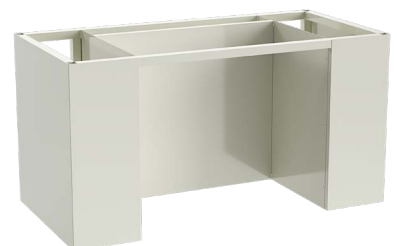

60" with Two 12" Chases
(HBF-3248 shown)

Height	Part Number
30"	HBF-3060
32"	HBF-3260
35"	HBF-3560

Sash Options

To order these optional sashes, please refer to the Ordering Guide on the back cover of this catalog. The large, underlined number in each of the part numbers below is the Sash Style number to use when ordering.

COMBO HORIZONTAL/VERTICAL SASH

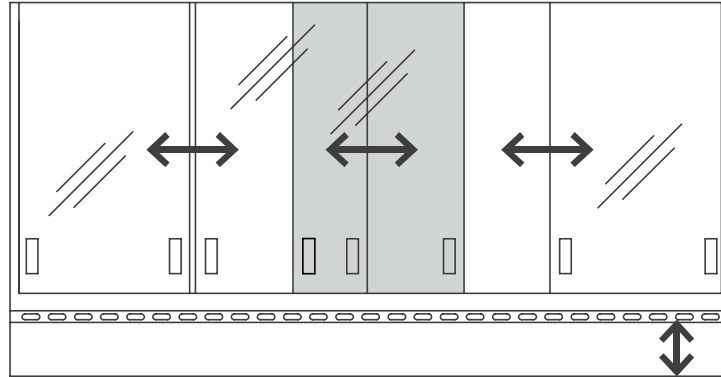

HORIZONTAL SASH ONLY

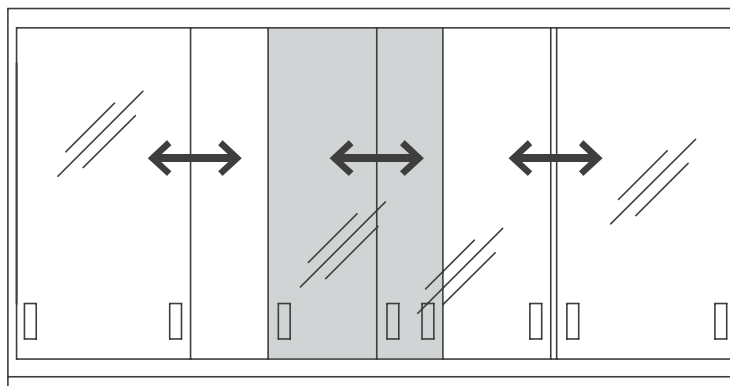

INTERLOCKING SASH

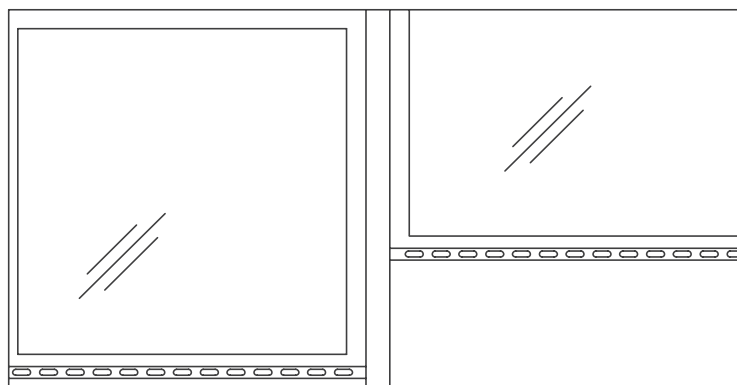

Sash Options

HANGING HORIZONTAL DOORS

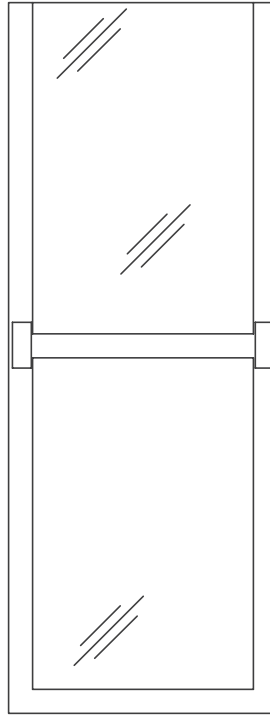

ADDITIONAL SASH OPTIONS

- **SASH ALARM:**
A red light alarm activated when sashes is opened above a pre-set height.
- **SASH STOP:**
A device to limit sash opening, with manual override.
- **AUTO SASH RETURN:**
Returns sash to 18" working height when opened beyond set height.
- **SASH INTERLOCK:**
Allows only one sash to be opened at any time on a double-sided hood.
- **DOUBLE HUNG SASH:**
For larger openings with ceiling height limitations.
- **SASH LOCK:**
A keyed lock that keeps the sash closed if needed in a classroom setting.
- **PUSHBUTTON SASH**:**
Opens and closes sash with the push of a button.
- **AUTO-SENSING SASH**:**
Automatically closes sash when operator walks away.

**These two types of sashes have a wide range of capabilities. Please call an Air Master Systems representative or the factory to determine which application is right for your needs.

Epoxy Resin & Stainless Steel Surfaces

Another key component of effective and efficient fume hood utilization is the type of work surface to use. Inappropriate work surfaces can interfere with lab processes and be a potential danger to lab personnel. Air Master Systems Corporation provides durable, high-performance epoxy resin and stainless steel surfaces that feature top quality materials and workmanship.

EPOXY RESIN

Epoxy resin fume hood surfaces provide a durable, chemical resistant work surface for the harshest laboratory environment. The work surface is surrounded by a 3/8" (10mm) integrally-molded containment rim designed to ease clean-ups and prevent hood and casework damage from large chemical spills.

Oval 3" x 6" (7.65 x 15.3cm) cup sinks are standard; locations must be specified when ordering. Other sinks sizes are available upon request.



STAINLESS STEEL

Stainless steel work surfaces are fabricated of 304 stainless steel, are 1-1/4" (3.2cm) thick and dished 3/8" with a #4 smooth satin finish. Square 3" x 6" (7.65 x 15.3cm) welded cup sinks are standard; locations must be specified when ordering.

*In perchloric acid applications, 316 stainless steel is used for lab safety.

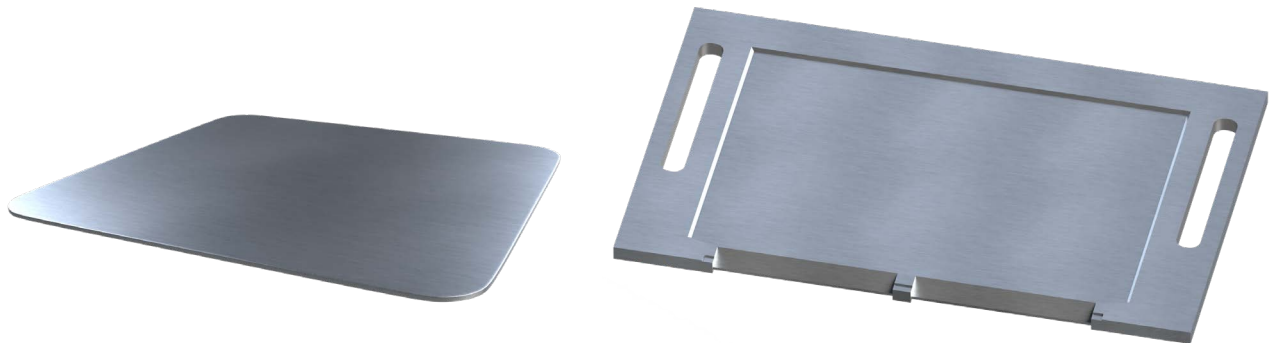

Epoxy Resin & Stainless Steel Surfaces

Another key component of effective and efficient fume hood utilization is the type of work surface to use. Inappropriate work surfaces can interfere with lab processes and be a potential danger to lab personnel. Air Master Systems Corporation provides durable, high-performance epoxy resin and stainless steel surfaces that feature top quality materials and workmanship.

100 & 500 SERIES WORK SURFACES

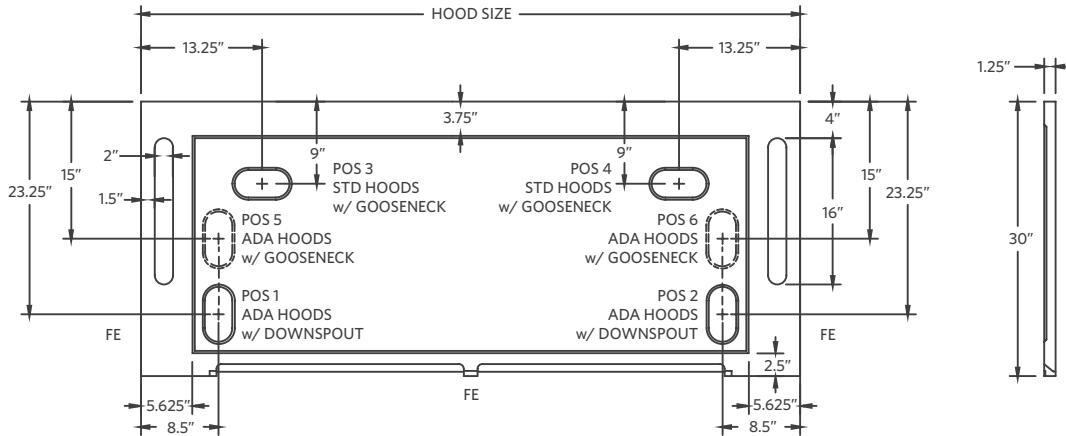

200 SERIES WORK SURFACES

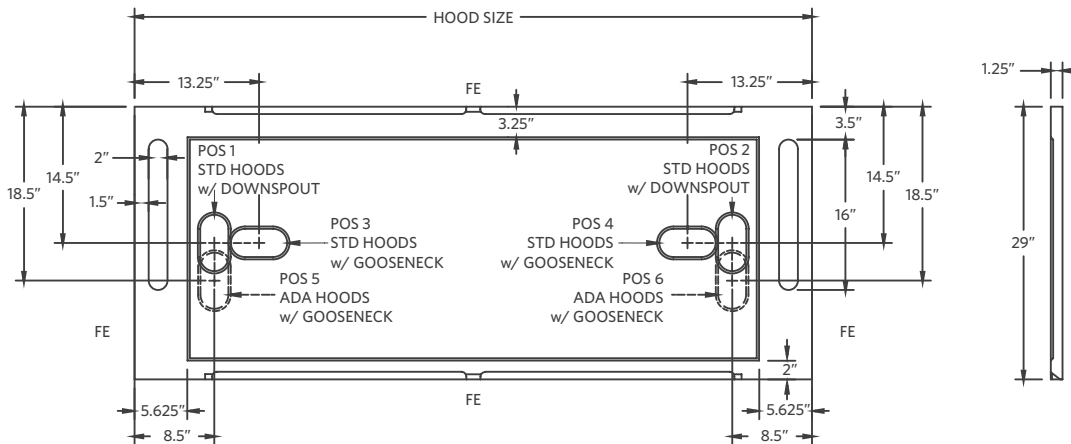

300 SERIES WORK SURFACES

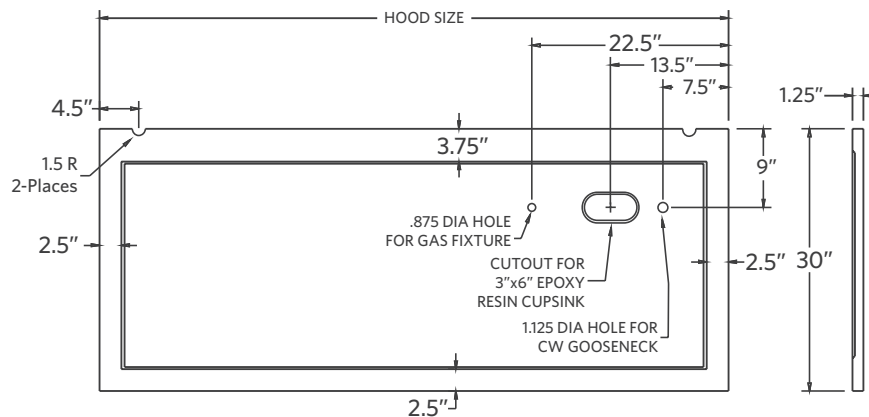

Epoxy Resin & Stainless Steel Surfaces

Another key component of effective and efficient fume hood utilization is the type of work surface to use. Inappropriate work surfaces can interfere with lab processes and be a potential danger to lab personnel. Air Master Systems Corporation provides durable, high-performance epoxy resin and stainless steel surfaces that feature top quality materials and workmanship.

800 SERIES WORK SURFACES

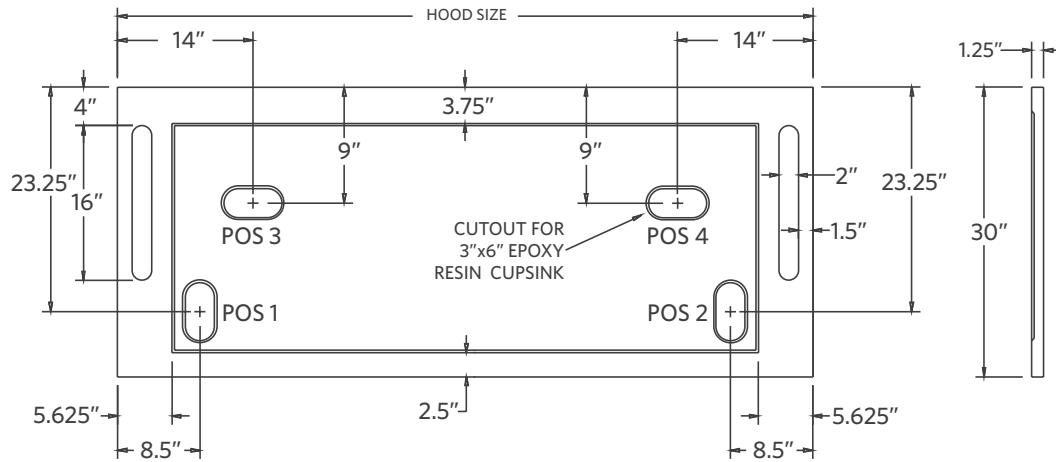

Custom Stainless Steel Countertops

Primarily used for all general purpose fume hoods and base cabinets, standard stainless steel countertops are fabricated of 16-gauge 304* stainless steel with a #4 smooth grain finish and are 1-1/4" (3.2 cm) thick and dished 3/8" (0.97 cm). A 4" integral backsplash comes standard and, when sinks or end splashes are required, they are continuously welded to the top and professionally buffed to a #4 finish.

Countertop standard depth is 30" and can be made up to any length required to include a field joint or continual counter depending on the specific job requirements. The tops also have a rubberized sound deadening material applied to soften the sound of the top and make it more acoustically appealing.

Rectangular 3" x 6" (7.65 x 15.3 cm) welded cup sinks are standard; locations must be specified when ordering.

**Use of perchlorics requires use of 316 stainless steel for lab safety.*

MARINE EDGE COUNTERTOPS

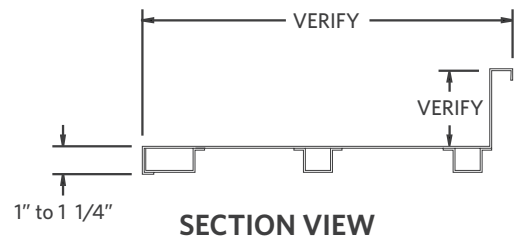
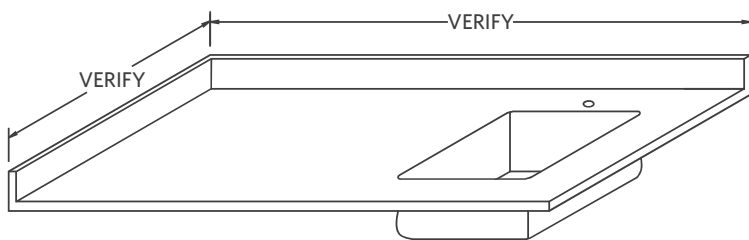

SPECIAL COUNTERTOP w/ DOUBLE SINK

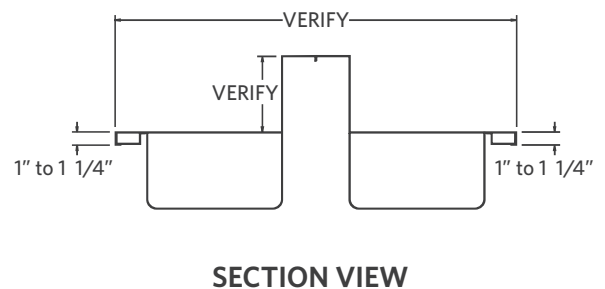
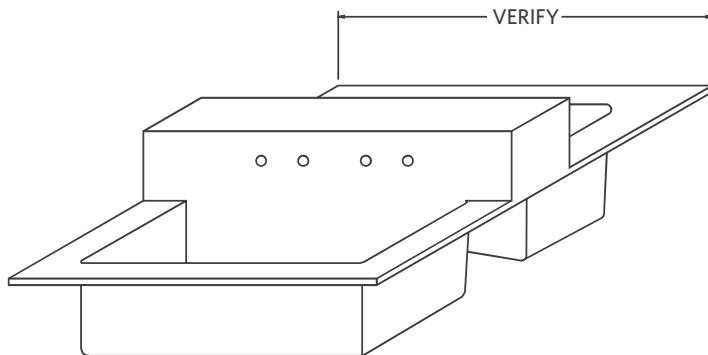

SPECIAL COUNTERTOP w/ DOUBLE SINK

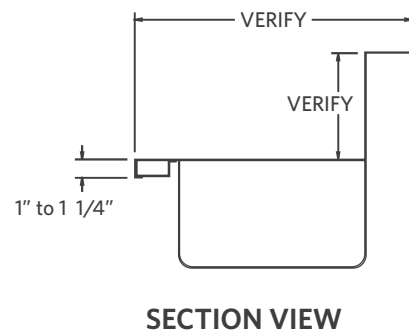
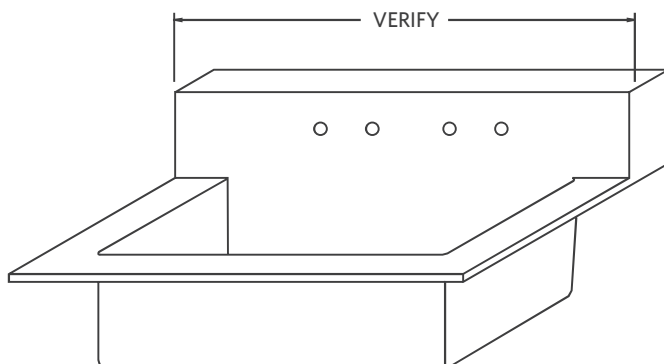

Knock Down Hoods

Most AMS hoods can be knocked down into manageable modules. This can be very useful when retrofitting old labs, or for easier installation of large hoods. This feature also allows for container shipment packaging.

Safe Easy disassembly and reassembly for a multitude of applications

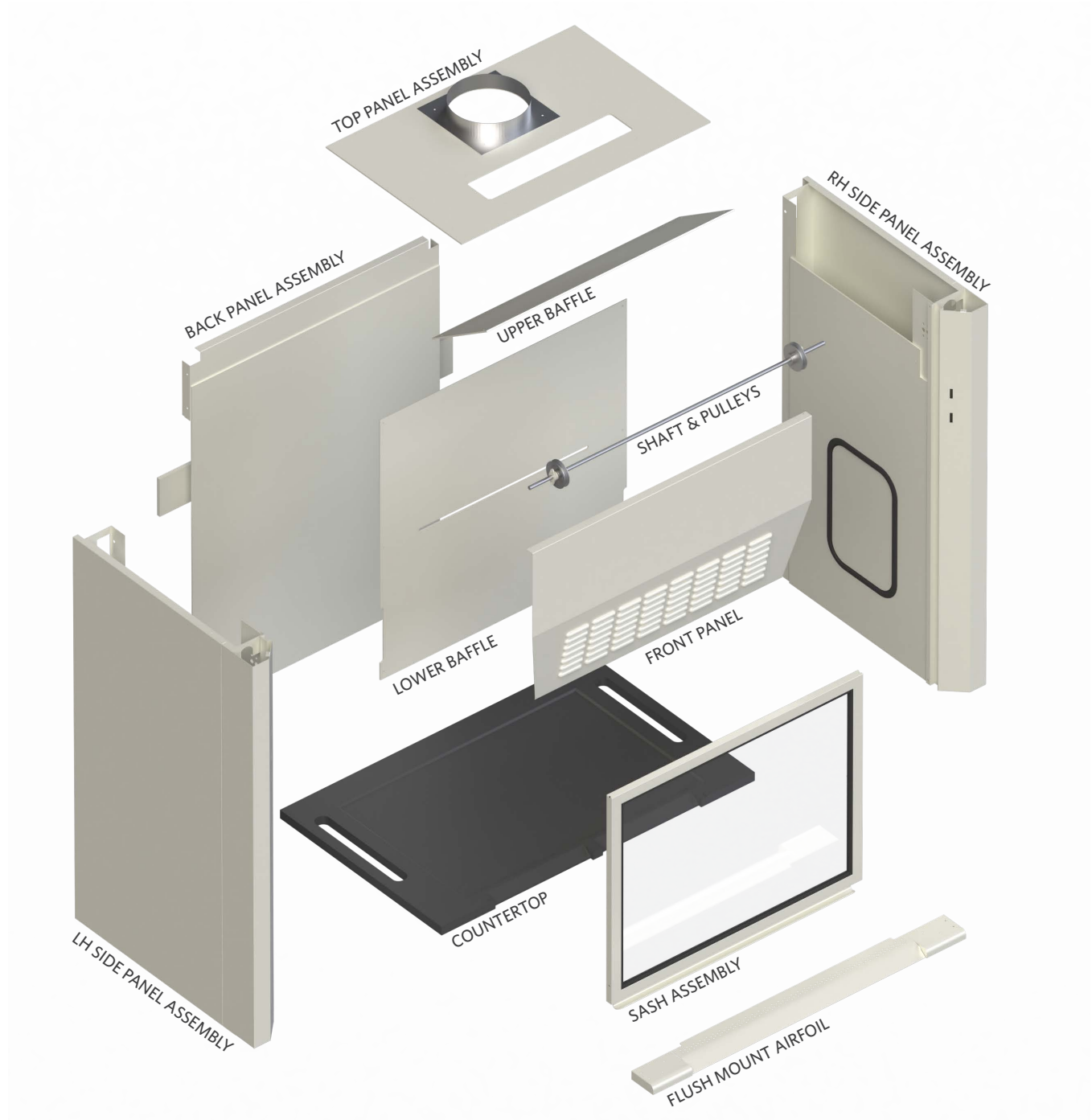

Fume Hood General Design Requirements

1.01 FUME HOOD GENERAL DESIGN REQUIREMENTS

- A.** Fume hoods shall function as ventilated, enclosed workspaces, designed to capture, confine and exhaust fumes, vapors and particulate matter produced or generated within the enclosure.
- B.** Design fume hoods for consistent and safe air flow through the hood face. Negative variations of face velocity shall not exceed 20% of the average face velocity at any designated measuring point as defined in this section.
- C.** Average illumination of work area: Minimum 80 foot-candles. Work area shall be defined as the area inside the superstructure from side to side and from face of baffle to the inside face of the sash, and from the working surface to a height of 28 inches.
- D.** Fume hood shall be designed to minimize static pressure loss with adequate slot area and stainless steel exhaust collar configuration. Maximum average static pressure loss readings taken three diameters above the hood outlet from four points, 90 degrees apart, shall not exceed the following maximums.

Face Velocity	Measured SPL (WG)
100 FPM	.30 inches
125 FPM	.45 inches
150 FPM	.60 inches

1.02 SUBMITTALS

- A.** Shop Drawings: Indicate equipment locations, largescale plans, elevations, and cross sections, rough in and anchor placement dimensions and tolerances and all required clearances.
- B.** Product Data: Submit manufacturer's data for each component and item of laboratory equipment specified. Include component dimensions, configurations, construction details, joint details, and attachments, utility and service requirements and locations.
- C.** Samples: Submit 3" x 6" inch samples of finish for fume hood, work surfaces and for other pre finished equipment and accessories for selection by Architect.
- D.** Test Reports: Submit test reports verifying conformance to test performances specified. Submit independent tests as specified.

1.03 QUALITY ASSURANCE

- A.** Single source responsibility: Fume hood casework, work surfaces, and other laboratory equipment and accessories shall be manufactured or furnished by a single laboratory furniture company.
- B.** Manufacturer's qualifications: Modern plant with proper tools, dies, fixtures and skilled worker to produce high quality laboratory casework and equipment, and shall meet the following minimum requirements:
 - 1.** Ten years or more experience in manufacturing of laboratory casework and equipment of type specified.
 - 2.** Ten installations of equal or larger size and requirements.
- C.** Installer's qualifications: Factory certified by the manufacturer.
- D.** Product shall be manufactured and assembled in the United States of America.

1.04 DELIVERY, STORAGE AND HANDLING

- A.** Schedule delivery of equipment so that spaces are sufficiently complete that equipment can be installed immediately following delivery .
- B.** Protect finished surfaces from soiling or damage during handling and installation. Keep covered with polyethylene film or other protective coating.
- C.** Protect all work surfaces throughout construction period with 1/4" corrugated cardboard completely covering the top and securely taped to edges. Mark cardboard in large lettering "No Standing."

1.04 DELIVERY, STORAGE AND HANDLING

- A.** Do not deliver or install equipment until the following conditions have been met:
 - 1.** Windows and doors are installed and the building is secure and weather tight.
 - 2.** Plumbing, overhead ductwork and lighting are installed.
 - 3.** All painting is completed and floor tile located below casework is installed.

Fume Hood General Design Requirements

2.01 FUME HOOD MATERIALS

A. Steel: High quality, cold rolled, mild steel meeting requirements of ASTM A366; gauges U.S. Standard.

B. Stainless Steel: Type 304 or 316; gauges U.S. Standard

C. Ceiling closure panels: Minimum 18 gauge; finish to match hood exterior.

D. Bypass grilles: Low resistant type, 18 gauge steel, upward directional louvers.

E. Safety glass: 7/32" thick laminated safety glass.

F. Sash cables: 7 x 7 steel, coated, 1/8" diameter coated to 5/32". (Military spec. quality.)

G. Sash guides: A full length extruded corrosion resistant polyvinyl chloride or powder coated steel with PVC guides to protect against metal to metal contact.

H. Pulley assembly for sash cable: 2" diameter, steel construction, ball bearing type, with cable retaining device.

I. Sash pull: Full width 16 gauge steel to match hood color.

J. Interior access panels: To be made of the same material as the fume hood liner with an easily removable PVC gasket.

K. Fastenings:

1. Exterior structural members attachments: Sheet metal screws, zinc plated.
2. Interior fastening devices concealed. Exposed screws not acceptable.
3. Exterior panel member fastening devices to be corrosion resistant non-metallic material. Exposed screws not acceptable.

2.02 FUME HOOD CONSTRUCTION

A. Superstructure: Rigid, self-supporting assembly of double wall construction, maximum 5-1/4" thick.

1. Wall consists of a sheet steel outer shell and a corrosion resistant inner liner, and houses remote operating service fixture mechanisms and electrical services.

2. Access to fixture valves concealed in wall provided by exterior removable access panels, gasketed access panels on the inside liner walls, or through removable front posts.

3. Hoods must be of full frame construction. Hoods that use metal brackets and spacers to hold interior and exterior panel in place are unacceptable.

B. Exhaust outlet: 10" round, 20 gauge stainless steel exhaust collars.

C. Access opening perimeter: Top and sides of face opening to be radiused or angled.

1. Bottom horizontal: foil shall be a flush-mount type and provide a 1" bypass to insure a clean sweep and to minimize eddies along the work surface when sash is in the closed position. For ADA fume hoods, a secondary containment trough with flush mount airfoil to be provided.

2. Bottom sash rail: 1-1/2" frame section, 16-gauge steel or PVC. Provide pull, full width of bottom rail.

3. Set safety glass into rails in deep form, extruded polyvinyl chloride or neoprene glazing channels if a steel sash frame is being used.

4. Counter balance system: Single weight, pulley, cable, counter balance system which prevents sash tilting by means of a shaft driven" system and permits one finger operation at any point along full width pull.

Sash not using this type of counter balance systems are unacceptable. Maximum 9 pounds pull required to raise or lower sash throughout its full length of travel. Design system to hold sash at any position without creep and to prevent sash drop in the event of cable failure.

5. Open and close sash against rubber bumper stops.

D. Fume hood liner: 3/16" Polyresin: Reinforced polyester panel smooth finish and white color in final appearance. Flexural strength: 14,000 psi. Flame spread: 15 or less per U.L. 723 and ASTM E84-80.

E. Baffles: Fabricate fixed baffles providing controlled air vectors into and through the fume hood of the same material as the liner. Hoods with adjustable baffles are unacceptable. All baffle support brackets to be non-metallic.

Fume Hood General Design Requirements

F. Service fixtures and fittings: Color-coded hose nozzle outlets and valves mounted inside the fume hood and controlled from the exterior with color-coded index handles (when specified).

1. Valves: Rod-driven needlepoint type with self-centering cone tip and seat of hardened stainless steel.
2. Provide pre-piping for all service fixtures from valve to common point for final connection by respective trades. 1/2" OD copper tubing for water, air, gas and vacuum. All type "L" copper connections & elbows are made with Vega ProPress fittings.
3. Fixtures exposed to hood interior: Brass with chemically resistant powder coating.
4. Remote control handles: Prong type, easy to grasp.
5. Services: To be determined by Architect/Planner.

G. Hood light fixtures: Two lamp, rapid start, T-8 UL listed fluorescent light fixture with sound rated ballast installed on top panel.

1. Interior of fixture: White, high reflecting plastic enamel.
2. Size of fixture: Largest possible up to 48" for hoods with superstructures up to six feet. Provide two 24" fixtures for hoods with eight foot superstructures.
3. Include lamps with fixtures.
4. Illumination: Per performance values, part 1 of this section.
5. Provide switch with black acid resistant thermoplastic (when specified).
6. 3-way switch on each side of double sided hoods (when specified).

H. Electrical services: Provide on each front post of hoods. Three wire grounding type receptacles rated at 120v GFI, 20 amperes where specified. Flush Plates: Black acid resistant thermoplastic.

I. Work surfaces: 1-1/4" thick dished a nominal 1/4" to contain spills.

1. Molded resin work surfaces for hoods with white Resisto Roe or Poly-resin liners. Front raised edge no more than 1/2" wide.

J. Safety Monitor/Alarm System: Provide safety Monitor/Alarm system that monitors face velocity and provides audible and visual alarm if face velocity drops below safe levels. The technology used in the TEL 500 will be based on thermally compensated thermistor based in the alarm module. As the

internal fume hood pressure changes as the sash opening is closed and opened, the flow passing over the thermistor is calibrated to a face velocity that is displayed on the front of the monitor.

1. Safety monitor: UL listed, tamper proof, with all alarm circuits, electric components, external tubing, and manifolds furnished complete and factory installed. Monitor shall have light emitting diode display that provides clear indication of airflow conditions.
2. Calibration is the responsibility of the owner and is required once the hood is stationed and the hood exhausts and room supply systems are balanced. A secondary calibration has been factory set into the alarm's memory only to determine that the alarm is functional and ready for shipment. The primary calibration must be completed in the field.
3. Airflow sensor: Thermally compensated glass beaded thermistor, factory connected to a sidewall port on the interior of the fume hood.
4. Alarm Signal: Audible signal and visual, red light emitting diode:
 - a. Silence pushbutton, which disables the audible alarm, shall be accessible on the front of the safety monitor.
 - b. Provide alternate mode in which visible alarm is silenced indefinitely but visual alarm remains activated until the alarm condition is corrected.
 - c. When alarm condition is corrected and face velocity and volume return to specified levels, the Safety Monitor will automatically reset and begin routine monitoring.
 - d. Provide test circuit to verify proper Safety Monitor operation.
 - e. Electrical rating: Maximum 12 VDC, and maximum current rating of 20 OMA.
 - f. Provide a option for a sash alarm / sensor if required.

2.03 CEILING ENCLOSURE: Provide ceiling enclosure from top of hood to accommodate a ceiling height (verify). Fabricate enclosure from 18 gauge steel to match the hood material and finish.

A. Preparation: Spray clean metal with a heated cleaner/ phosphate solution.

B. Application: Electro statically apply powder coat of selected color and baked in controlled high temperature oven to assure a smooth, hard satin finish. Surfaces shall have a chemical resistant

Fume Hood General Design Requirements

high grade laboratory furniture quality finish of the following thickness:

1. Exterior and interior surfaces exposed to view: 1.5 mil average and 1.2 mil minimum.

2.03 CEILING ENCLOSURE:

A. Demonstrate fume hood performance by means of documentation of a third party testing company to the ASH RAE 110-1995 methods of testing.

Fume Hood Technology - Glossary

Airfoil: Shaped or streamlined member at hood entrance designed to enhance movement of air into the hood.

Air Volume: Rate of airflow, normally expressed in cubic feet per minute (CFM).

ASHRAE: American Society of Heating, Refrigerating, and Air Conditioning Engineers, a professional organization that sets industry standards for fume hood testing procedures.

Auxiliary Air: Supply or makeup air delivered external to the chamber of a fume hood to reduce air consumption.

Baffle: Panels located across back of hood interior, which control pattern of air moving through the hood.

Blower: Air moving device (or fan) consisting of motor, impeller, and scroll.

Bypass: Compensating opening that helps maintain constant volume exhaust from fume hood, regardless of sash position.

Canopy Hood: Ceiling or wall suspended ventilating device for noncritical use with heat, water vapor, odors, etc.

CFM: Cubic Feet Per Minute, a unit of measurement of air volume.

Combination Sash: Horizontal panels in a vertically rising frame; see *sash*.

Constant Volume: Type of fume hood exhaust system that exhausts the same volume of air, regardless of sash position.

Containment: Extent to which fumes are confined within the hood compartment.

Damper: Device installed in duct to control air volume.

Demonstration Hood: Fume hood with glass panels on two or three sides to improve visibility for demonstrating experiments in a classroom setting.

Exhaust Volume/Parameters: Quantity of air exhausted by the fume hood; quantity of air required to maintain desired face velocity, expressed in cubic feet per minute (CFM).

Face Velocity: Speed of air moving into the fume hood through the face opening (through the sash), measured in feet per minute (FPM).

FPM: Feet per minute; measurement of air velocity.

Liner: Fume hood interior sides, back, and top, including baffle.

Lintel: Portion of fume hood front located above access opening

Louvers: Slit-like openings in the lintel that allow bypass air to enter the hood when the sash is closed.

NFPA: National Fire Protection Association.

Negative Pressure: Pressures lower than one atmosphere.

Positive Pressure: Pressures higher than one atmosphere.

Restricted Bypass Fume Hood: Fume hood operating type, designed with limited bypass area; commonly used in conjunction with Variable Air Volume (VAV) exhaust systems and restricted sash opening designs.

Sash: Sliding glass panel set in the fume hood face that provides access to the hood interior.

Service Fitting/Plumbing: Water faucets and gas valves mounted on or fastened to the fume hood.

Static Pressure: Air pressure, or resistance, in fume hood or duct, expressed in inches of water.

U.L. 1805: Underwriters Laboratories certification that verifies conformance to electrical, mechanical, and airflow standards.

Variable Air Volume (VAV): Type of fume hood exhaust system that typically maintains constant fume hood face velocity by adjusting blower motor speed or a balance damper in response to changes in sash position.

Velocity: Speed of air, measured in feet per minute (FPM).

Velocity Pressure: Force per square inch applied by moving air.

Volume: Quantity of air, usually measured in cubic feet per minute (CFM).

Work Surface: Top material; area in fume hood where apparatus rests and where work takes place.



Material Handling USA

**Call Now for a Free
Quote or Site Visit!**

222 S. Main St. 5th Floor
Salt Lake City, UT 84101
800-326-4403
<https://www.mh-usa.com/>

SUPERSTORE

MH-USA

Material Handling USA

 **Material Handling USA**
800-326-4403
<https://www.mh-usa.com/>