

Operation & Maintenance Manual

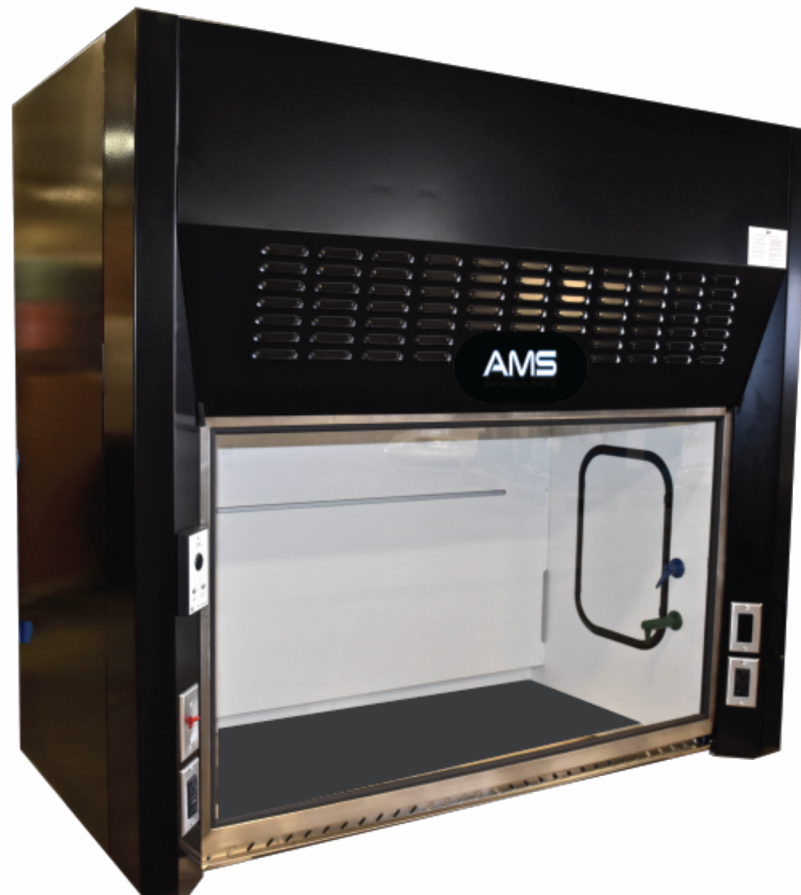



Material Handling USA
Call Now for a Free Quote or Site Visit!
222 S. Main St. 5th Floor
Salt Lake City, UT 84101
800-326-4403
<https://www.mh-usa.com/>
Material Handling USA

SUPERSTORE

MH-USA

Operation and Maintenance Guide

Operation and maintenance begins with the proper start up, normally provided by your Lab Manager , Classroom Supervisor or EH&S personnel. A typical laboratory operating procedure addresses practices such as those suggested below.

- Make sure the exhaust fan is operating prior to starting an experiment.
- Keep experiments and equipment 6” or more from the front edge of the sash.
- If possible, raise equipment off the counter top to facilitate air movement below.
- Wear protective clothing such as safety goggles, gloves, and lab coats.
- Keep the sash closed except when loading or unloading the experiment.
- Keep the sash window clean and clear.
- Immediately clean up any major spills occurring inside the fume hood.
- Remove all residues from the fume hood chamber once the experiment is complete.
- Keep the light fixtures clean and replace the bulbs whenever necessary.

It is recommended that a clean working environment be promoted for both safety and operation of the fume hood.

It is the responsibility of the user to consult with the Lab Manager or Classroom Supervisor for additional lab safety procedures and practices. When conducting an experiment within the fume hood, it is the user’s responsibility to understand and follow the lab safety procedures and practices.

All spills inside the fume hood should be cleaned up immediately with a neutralizing compound as required by your facility manager. Spills must be flushed and cleaned thoroughly to ensure lab safety.

Weekly Maintenance

General maintenance or housekeeping should be done on a weekly basis. This consists primarily of cleaning the side walls, baffles, counter tops and sash of any dirt or debris that may have collected. All surfaces can be cleaned with a mild detergent and water. If a large amount of build up is present, a qualified laboratory technician should observe the contents and oversee the cleaning procedure to ensure the integrity and proper operation of the hood and the safety of lab personnel.

Monthly Maintenance

Glass, cables, pulleys, sash guides, and plumbing handles are the only parts that move on the fume hood. These items should be checked on a monthly basis to note any damage or excessive wear and tear. These parts should be replaced as soon as damage or excessive wear has been observed.

The sash glass should be replaced if there are any chips, cracks or scratches that prevent a clear view of the interior of the fume hood. The cables on top of the fume hood should be replaced if there is damage to the protective coating which prevents smooth operation of the sash. Plumbing handles should turn only in a clockwise or counterclockwise direction. If the handles seem loose or wobbly, check the screw behind the index button or the cotter pin that connects the handle to the valve.

Annual Maintenance

The hoods must be balanced to maintain the proper air flow across the face of the fume hood. This procedure should be performed on an annual basis to make sure all exhaust fans are performing properly, and proper air flow is being achieved. Contact your local HVAC contractor for assistance with balancing the air flow.

Additional Accessories

If additional accessories have been added to your specific fume hood, such as magnahelic gauges or air flow monitors, a separate manual specifically addressing those items has been supplied and should be consulted.

Stainless Steel Work Surfaces

Upon receipt of your order, please take care to inspect the products to be sure that they have been made to order, and that damage has not occurred in transit. There is a five day window to report any damage you should find. In this unlikely event, please contact us or the dealer that you purchased from, and we will assist you promptly.

Our stainless-steel countertops are made with a type 304 stainless steel, with a number 4, b-brushed finish. Countertops are guaranteed, under normal usage, for a one-year period from the date of receipt. This warranty is null and void if damage has occurred as a result of mistreatment or non-typical use of the product. All of our stainless steel products should be received in a shiny and new condition. To maintain that new appearance, we recommend using a stainless-steel cleaner and polish. Clean up spills and residue immediately to help maintain a new appearance. Consult with your safety officer regarding proper clean up procedures and disposal.



Material Handling USA

**Call Now for a Free
Quote or Site Visit!**

222 S. Main St. 5th Floor
Salt Lake City, UT 84101
800-326-4403
<https://www.mh-usa.com/>

SUPERSTORE

MH-USA

Material Handling USA

Air Monitor Alarms



AFA 500 Mk3 Fume Hood Airflow Monitor Specifications

Part #AMS-ALRG

Alarm range	30-400 fpm (.15 -2.0 m/s)
Accuracy	Face velocity accuracy +/- 10%
Airflow sensor	On-board or remote sensor
Calibration	Single or 2-point (Installer selectable)
Low Air Alarm delay	Fixed 5 secs
Relay output	1 --(Low Air alarm)
Analog output	Not available
Relay input	2 – Night setback & sash high
Comm. Port	RS232 – Can be connected via serial interface to LAN network (Full hood performance software reporting available)
Sash high indication	Yes – using a Micro switch or Proximity switch input With repeat alarm feature factory set to 5 min. (Can be adjusted via laptop up to 30 mins)
Night setback	Yes – using a relay input
External alarm indication	Not available
Power Requirement	Input—120VAC, 60Hz Output—15VDC, 500ma
Display—visual	LEDs: red, alarm; green, normal
Alarm indication	Red LED & audible alarm
Horn silence	Yes – temporary
Mounting	Semi Flush
Operating temperature	55-86 F (13-30 C)
Storage temperature	-40-150 F (-40-65 C)
Instrument dimensions	Instrument Case: 5.2” H x 3.19” W x 1.97” D (132mm H x 81mm W x 50mm D)
Agency listings	UL & CE



AFA 1000/1 Mk3 Fume Hood Airflow Monitor Specifications

Part #AMS-AL1D

Display range	0-999 fpm (0-5.0 m/s)
Alarm range	0-999 fpm (0-5.0 m/s)
Field set-up	2-point velocity calibration (with on-screen instructions)
Accuracy	Sensor / Display resolution 1 fpm Face velocity accuracy +/-10%
Alarm delays	User configurable – 0 to 60secs
Relay output	4 (1 on board – 3 on optional plug in relay interface unit)
Analog output	0-10V output, directly proportional to velocity (Optional)
Relay input	3
Comm. Port	RS232 – Can be connected via Serial interface to LAN network (Full software available)
Sash high indication	Yes, with separate plug-in connection
Night setback	Yes
External alarm indication	Yes
Power Requirement	Input—120VAC, 60Hz Output—15VDC, 500ma
Units	English and Metric (user selectable)
Display—visual	Analog bar graph or Fault Timeline LEDs: red, alarm; yellow, caution; green, normal Digital display of velocity reading (can be turned off)
Alarm indication	Red LED & audible alarm (to a certain sound spec)
Horn silence	Yes (temporary / permanent/automatic depending on type of alarm or external input)
Mounting	Semi Flush
Operating temperature	55-86 F (13-30 C)
Storage temperature	-40-150 F (-40-65 C)
Instrument dimensions	Instrument Case: 5.2” H x 3.19” W x 1.14” D (132mm H x 81mm W x 29mm D)
Agency listings	UL & CE

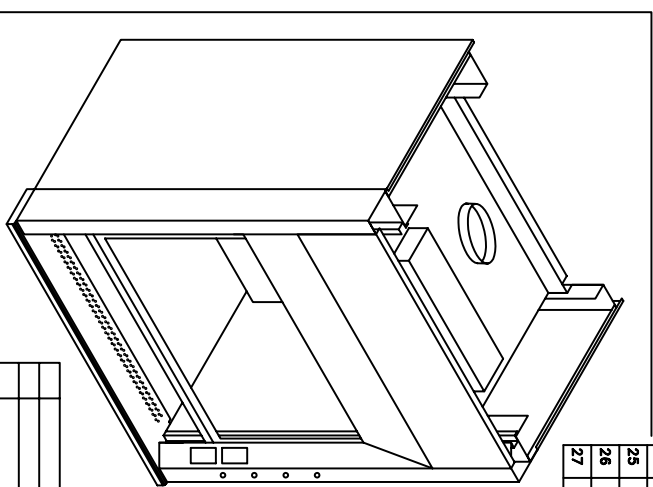
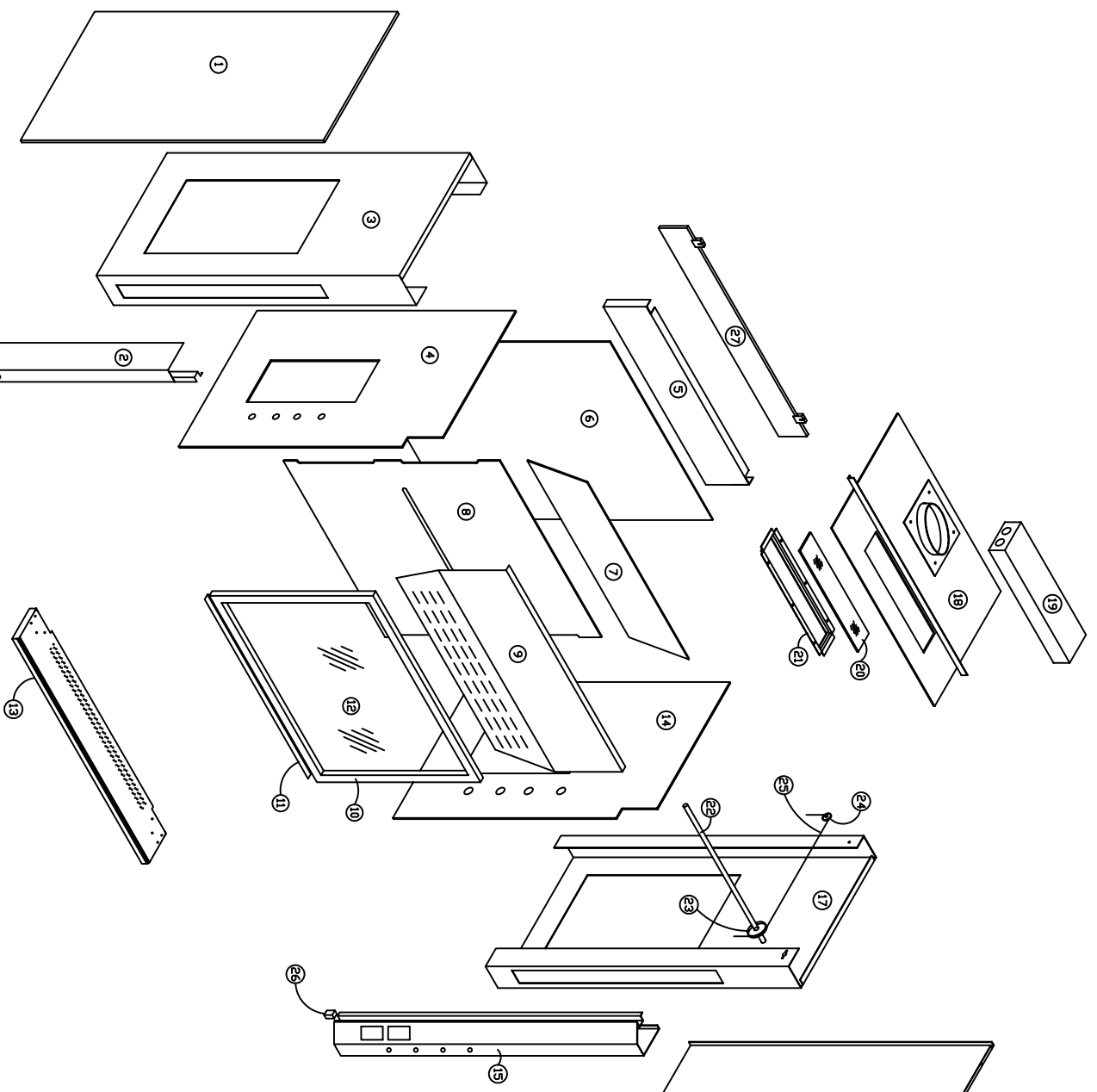

PARTS LIST FOR EH 111 STYLE HOODS

1	LH EXTERIOR METAL SIDE PANEL
2	LH POST FRONT
3	LH FRAME STRUCTURAL SUPPORT
4	LH INTERIOR POLYRESIN SIDE PANEL
5	TOP REAR REINFORCEMENT
6	POLYRESIN BACK PANEL
7	UPPER POLYRESIN BAFFLE
8	LOWER POLYRESIN BAFFLE
9	FRONT PANEL
10	TUBE SASH FRAME
11	BOTTOM FINGER LIFT
12	1/4" CLEAR LAMI SAFETY GLASS
13	AIRFOIL
14	RH INTERIOR POLYRESIN SIDE PANEL
15	RH POST FRONT
16	RH EXTERIOR METAL SIDE PANEL
17	RH FRAME STRUCTURAL SUPPORT
18	POLYRESIN TOP PANEL
19	2-TUBE T-8 FLUORESCENT LIGHT
20	1/4" CLEAR LAMI LIGHT GLASS
21	LIGHT GLASS FRAME
22	STAINLESS STEEL CABLE SHAFT
23	FRONT SHEAVE
24	2" DIA NYLON PULLEY
25	7/7" STEEL COATED SASH CABLE
26	RUBBER BUMPER (FOR SASH)
27	SASH COUNTERWEIGHT

AMIS
STANDARD SOLUTION DESIGNER

AIR MASTER SYSTEMS CORP
6480 NORTON CENTER DR.
MUSKEGON, MI. 49441
TEL (231) 798-1111 FAX (231) 798-4000
WWW.DIRMASTERSYSTEMS.COM

PARTS LISTS FOR EH STYLE HOODS

REV	DESCRIPTION	BY	DATE
DRN	DATE	AMS JOB	
CHK'D	DATE	ITEM	
SCALE		SHEET	OF
CUSTOMER PO		DRAWING NO.	
CUSTOMER REF NO		PI-EH-111-HDS	
CUSTOMER JOB			
QUOTE NO			

Ceiling Enclosures & Finished Backs

Air Master Systems Corporation offers ceiling enclosures and finished backs to provide a professional, finished design in any setting. Ceiling enclosures and finished backs are fabricated of cold rolled steel and finished to match the fume hood superstructure.

The ceiling enclosures are available in two types: for standard fume hoods and also for those fume hoods utilizing the optional Air Chamber. Both enclosures conceal and protect the hood ductwork, electrical conduit and other supply lines.

Ceiling Enclosures: Order CE-W-H where W is hood width and H is height of enclosure required. Example: CE-48-18 is a set of enclosures for a 48" wide hood which are 18" high.

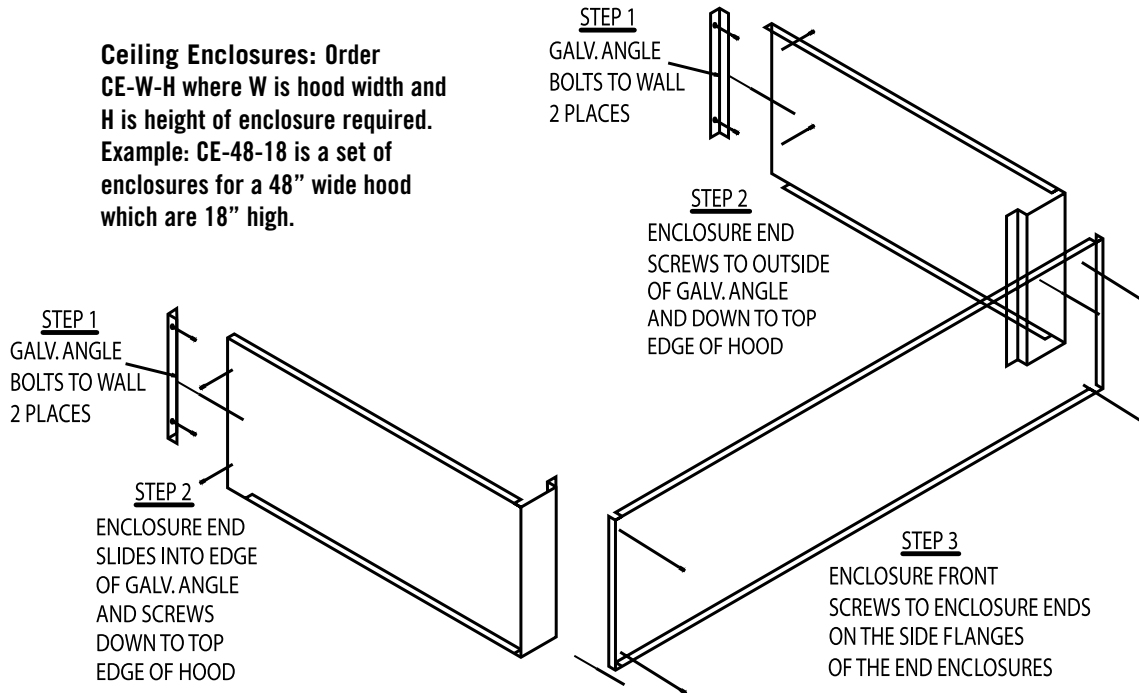

Finished backs are used to close off the back of the fume hood, giving it a finished look when located in the center of a room.

**Finished Backs:
Order FINBACK-W where
W equals hood width.**

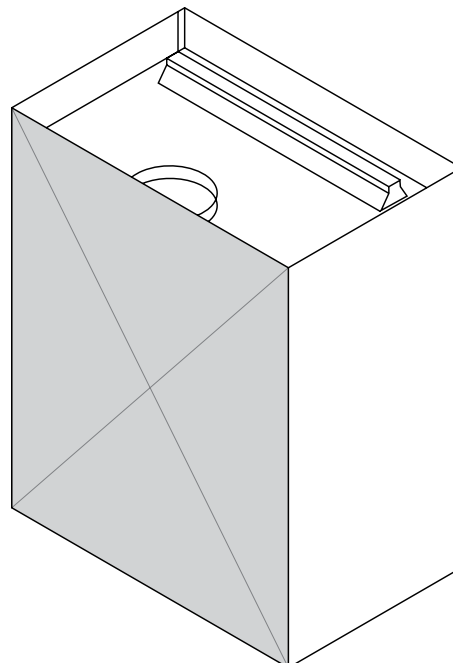

Electrical Accessories and Specifications

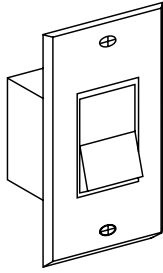

**Single Pole 15 Amp
Light Switch
Standard Black Color &
Cover Plate
Part# LTSW**

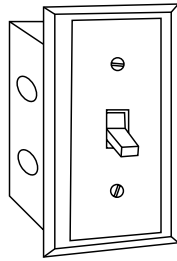

**Red Illuminated
Toggle Switch with
Black Cover Plate
Part# BLSW**

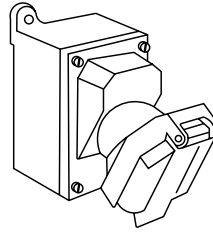

**Explosion Proof Outlet
Class 1, Group 1
Part# XPO**

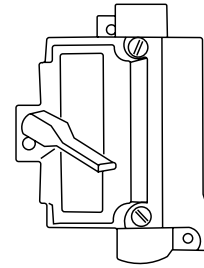

**Explosion Proof Switch
Class 1, Group 1
Part# XSW**

Pre-Wire service is completed in accordance with NEC and UL-1805 standards.

Note: If the fume hood is not pre-wired, wiring in the field must be accomplished using UL listed electrical fixtures while observing NEC standards and local electrical codes.

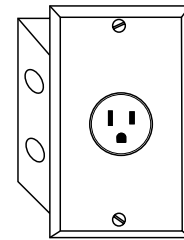

**208 Volt, 20 Amp Single
Pole Receptacle
230, 277 or other
available upon request
Part# 208**

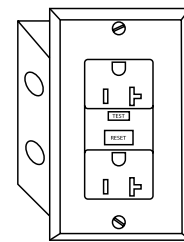
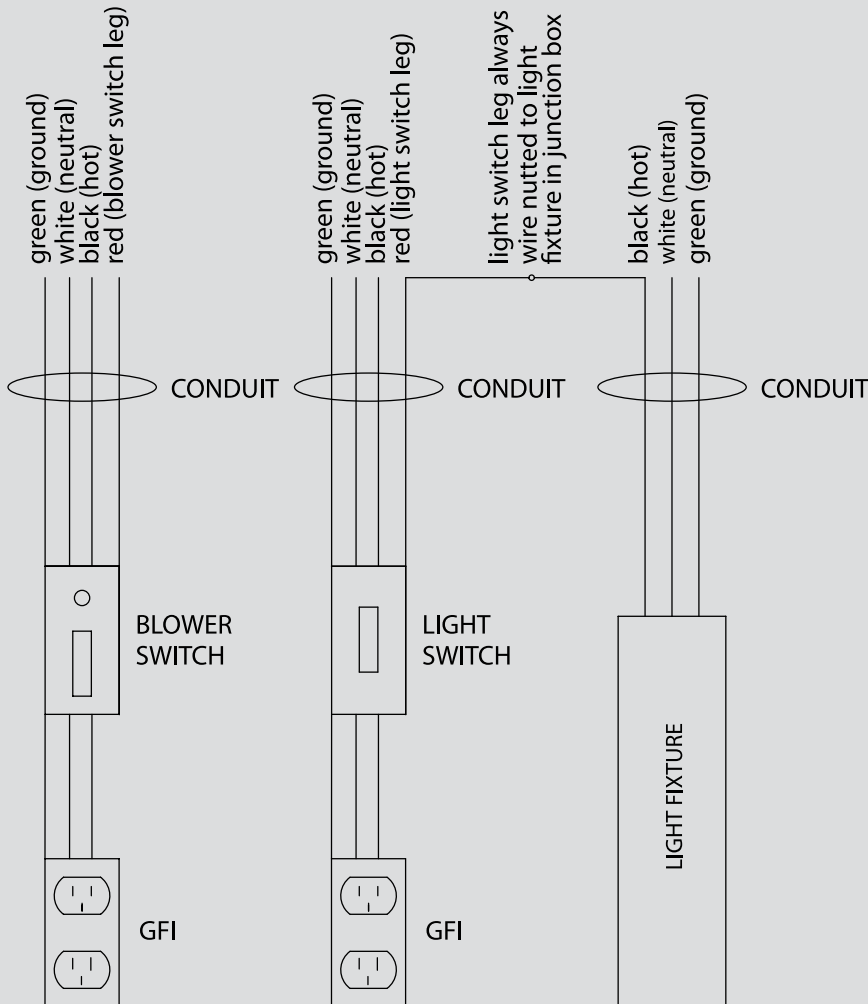

**120 volt 20 Amp Ground
Fault Interrupter (GFI)
Duplex Outlet Standard Black
color with cover
Part# GFI**



**Explosion Proof Light
Class 1, Group 1
Available in incandescent
or fluorescent
Part# XPL**

Care and Maintenance of Epoxy Resin Laboratory Work Surfaces

Epoxy Resin work surfaces are durable, non-porous, man-made stone products that are relatively unaffected by most chemicals, heat, flame and moisture. These super-tough surfaces' physical properties are seldom compromised; however, they do require periodic care and maintenance throughout the life of the lab or school room to keep the surfaces looking like new. Whether you are a facility owner, manager, custodian or lab user, it is helpful to know how to maintain the good appearance of your lab's work surfaces.



Chemical Resistant • Non-Absorbant • Self-Extinguishing

Regular Care Procedures

Durcon recommends instituting a regimen of monthly or quarterly inspections of all surfaces, sinks and joints, plus daily or weekly cleanings to maintain your epoxy resin's original finish and to help ensure a safe, uncontaminated working environment. The following list contains items you may wish to have on-hand for regular cleaning and to handle most problems that may occur.

- Acetone or Paint Thinner
- Crystal Simple Green®
- White Scotch Brite® Pads (always use moist or wet)
- Finish Oil (Mineral Oil)
- Murphy's Oil
- Clean Rags or Sponges
- Chamois Cloth
- Mild Soap or Household Cleaner
- Two-part Smooth-On® Epoxy Grout

Note: Never use wax or polish containing wax on epoxy resin work surfaces or sinks. Also, never use abrasive pads, powders or liquids (such as Soft Scrub) as dulling of the surface will result.



Work Surface Care

Promptly wipe up all spills. Acetone should be used (where allowed) to thoroughly clean surfaces. Apply and wipe away with a paper towel or a clean rag. As an alternative, Crystal Simple Green® (or comparable household cleaning product) can be used to clean surfaces.

An occasional application of finish oil or Murphy's Oil® can restore the luster to the surface, but remember; too much oil can cloud the surface.

- Apply oil by pouring the minimum amount of oil necessary to cover the surface area onto a clean rag.
- Thoroughly rub in oil using a circular motion.
- Wipe away excess oil with a clean rag.
- A chamois can be used to buff the surface to the desired sheen.

Epoxy Resin Sink Care

Laboratory sink areas usually present the greatest cleaning and maintenance challenges. Sinks are a collection point for dirty and wet lab ware which leaves liquids, residue and chemicals on the surface for extended periods of time. Sink areas will require a more thorough cleaning regimen than dry bench tops as well as more frequent inspections. Sink inspections should include all sink surfaces and joints in sink the area including the outlet joint and the sink rim joint above and below the work surface. Cracked or pitted joints should be filled immediately with two-part Smooth-On® epoxy grout to prevent leaking and damage to the supporting casework.

If there is a more serious cleaning issue it is important to identify the problem before trying to remedy it.

Marring

Most metals are softer than the work surface and can leave a mar if pulled across the top. Marring is matter left on the surface that appears as a line and remains smooth to the touch. Marring can almost always be removed with acetone or with mild cleaning products and elbow grease.

Always try the softest cloth and the weakest solution (soap and water) first.

If marring persists, progress to a white Light Duty Scotchbrite® Pad moistened with stronger solutions. Never use a dry Scotchbrite pad or a more abrasive pad and always apply the minimum amount of pressure required on the surface to remove the mar.

Scratches

Harder metals, abrasives and heavy or sharp items can dig into the surface resulting in a scratch. Scratches usually appear as a lighter shade of the surface and will be rough to the touch. Scratches in epoxy resin are permanent but will not affect work surface performance.

An aesthetic remedy for scratches is coloring in the void with a permanent marker. This option will never perfectly match the color and gloss of the surrounding surface.

Stained Surfaces

Staining can be caused by chemicals left to dry on the surface. Chemical stains usually lighten or bleach the surface but can also roughen and even crack the top. Like scratches, chemical stains are permanent and, if they have caused too much damage, you may need to replace of the top.

Special Care Issues

Epoxy resin products (especially glued in sinks) are subject to thermal shock and are not warranted against damage from liquid nitrogen or dry ice. Possible effects caused by the improper disposal of these materials include joint failure and/or sink fractures.

By following these simple guidelines your Durcon laboratory work surfaces will look good for the life of the lab. Please take time to share this document with your lab workers and cleaning personnel and institute a maintenance program to help ensure the safety and beauty of your lab. If you have further questions, please contact our customer service department at 512-595-8000 or send an e-mail to sales@durcon.com.



Introduction



WaterSaver faucets utilize an interchangeable unit or cartridge that is standardized across the product line. The unit contains all working components of the water faucet or valve. There are no moving parts in the faucet or valve body itself to wear out. As a result, WaterSaver water fittings are virtually everlasting.

Key features of the WaterSaver renewable unit are:

- The unit has outer serrations or splines to lock the unit in position in the faucet body. The unit cannot rotate or turn as the faucet is used. The handles of the faucet will maintain position, even with lever or wrist blade handles.
- The valve seat is machined from solid stainless steel bar stock. The main wearing component of the valve is thus ultra-hard and corrosion resistant for superior durability.
- A hard rubber valve disc provides positive shut-off of the water flow. The valve does not have a soft or “spongy” feel that reduces the ability to meter the water flow.
- The valve stem is sealed with a molded TFE packing. The packing prevents leakage over hundreds of thousands of cycles. An adjustable packing nut permits take up of wear.

The WaterSaver renewable unit has been in use since the late 1940s, and has provided high performance and durability in literally millions of faucets. The overall design and dimensions of the unit have never changed. As a result, every WaterSaver faucet ever made can use the same renewable unit that goes into every faucet we make today.

WaterSaver renewable units are manufactured in a variety of styles and configurations for the many applications in which they are used. These styles and configurations are described below:

- 1. Manual vs. Self-Closing Control.** Typical laboratory faucets and valves are manufactured with a renewable unit that has manual (also called compression) control. The unit is manually opened and manually closed by turning the valve handle. However, in certain applications, it is desirable to have a faucet with a self-closing valve and handle. WaterSaver therefore also manufactures renewable units with a spring-loaded valve mechanism. The faucet closes automatically when the handle is released. WaterSaver manual and self-closing units are dimensionally identical and therefore interchangeable. Faucets can be converted from manual to self-closing control, and vice versa, simply by changing the faucet cartridge.
- 2. Round Serrated Stem vs. Tapered Square Stem.** The WaterSaver renewable unit was originally manufactured with a round serrated stem end. Handles had a matching round serrated broach to fit on the stem. In 1991, we changed to a valve stem with a tapered square end. Handles were also changed to have a matching female taper. The tapered square end provides a much more solid, durable fit between the stem and handle. However, we still offer renewable units and stems with the round serrated end (the BNV100 series) for use in maintaining older faucets.
- 3. Right Hand Thread vs. Left Hand Thread.** A typical faucet or valve is opened by rotating the handle in a counterclockwise direction. The faucet or valve is closed by turning the handle in the opposite (clockwise) direction. This rotation is called “right hand” construction, since the thread on the valve stem is a right hand thread. The vast majority of faucets manufactured by WaterSaver work in this way. However, when faucets are furnished with wrist blade or lever handles, it is preferable to have the handles open in opposite directions. For example, on an L400 series deck mounted mixing faucet, both handles should open by rotating up and close by rotating down. This requires that the valve mechanisms open in opposite directions. One of the valve mechanisms must therefore be furnished with a valve unit that has a reversed (i.e. left hand) thread. The unit with the left hand thread will open in the clockwise direction and close in a counterclockwise direction. The left hand unit is typically, though not always, installed on the cold water side of the faucet.

4. 120 Degree vs. 90 Degree Rotation. Typical WaterSaver renewable units rotate approximately 120 degrees from the closed to open position. However, when a faucet is furnished with wrist blade or lever handles, it is advantageous for the handle to go from closed to open in a 90 degree rotation. This more limited rotation prevents the handles from hitting the counter or a backsplash behind the faucet. WaterSaver therefore offers the BNV200-90 series renewable units for use in faucets with wrist blade or lever handles.

5. Adjustable Volume Control. The original WaterSaver renewable unit incorporated an adjustable volume control device. This device consists of a small round cap or thimble held in place by a set screw. By loosening the set screw and rotating the thimble, the user can adjust the size of the inlet port through which the water passes as it enters the valve. By opening or closing the port, the user can compensate for high water pressure or conserve water. Effective in 1985, the adjustable volume control device was changed from a standard to an optional feature of our products. Renewable units with the suffix "AC" include the adjustable volume control feature.

6. Tin-Lined Units. Faucets and valves for distilled, deionized and purified water must be manufactured using inert materials that are in contact with the water. These inert materials protect the purity of the water, as well as prevent the purified water from corroding the faucet or valve itself. WaterSaver manufactures faucets and valves for purified water in tin-lined brass, PVC, polypropylene, polypropylene-lined brass, PVDF-lined brass and stainless steel. This wide selection of materials permits the use of products that meet the requirements of the particular application. Faucets and valves that are tin-lined brass use the same renewable unit as all

WaterSaver faucets. However, for purified water applications, the brass components of the unit are coated with a layer of pure tin. To order such units or components, add the suffix "TL" to the part number.

7. Check Valve. WaterSaver offers renewable units with an internal check valve. The purpose of the check valve is to prevent backflow of water upstream of the valve. This can be used to prevent cross-mixing of hot and cold water when the faucet is opened for a long period of time and the outlet may be closed. This can occur on units such as pre-rinse units where there is a self-closing valve downstream of the faucet valves. All WaterSaver pre-rinse units are furnished with renewable units with internal check valves. To order a renewable unit with an internal check valve, add the suffix "CV" to the part number.

8. Ceramic Disc Units. The original WaterSaver renewable unit is based on a compression valve design. The valve operates by means of a rubber disc that is compressed against a valve seat. When the handle is turned to open the faucet, the disc moves up off the seat, thus opening the waterway. When the handle is turned to close the valve, the disc is moved down to recompress against the valve seat. As an alternative to this type of construction, WaterSaver offers units that utilize rotating ceramic discs to control the water flow. The unit has two flat ceramic discs, each of which has a hole or port in it. When the handle is turned, the upper disc rotates, allowing the orifice in the upper disc to align with the orifice in the lower disc and opening the waterway. Units with rotating ceramic discs are dimensionally the same as, and thus interchangeable with, the standard WaterSaver compression renewable unit.

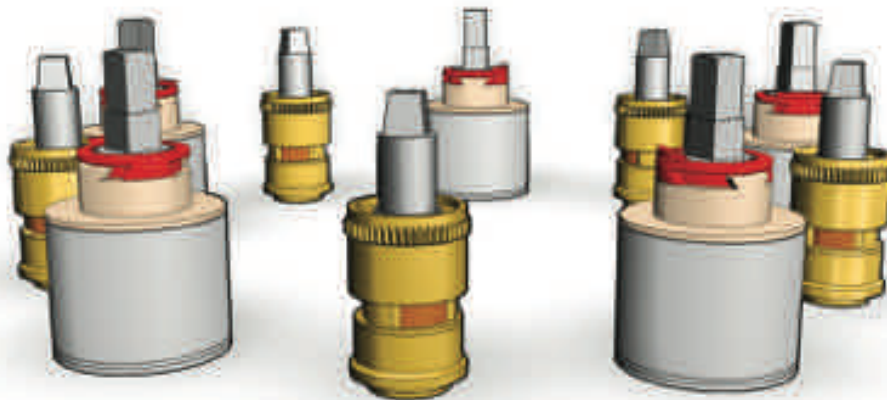

- **BV200N** Needle Valve Components
- **BV200N-PM** Needle Valve Components for Panel Mounted Fume Hood Valve

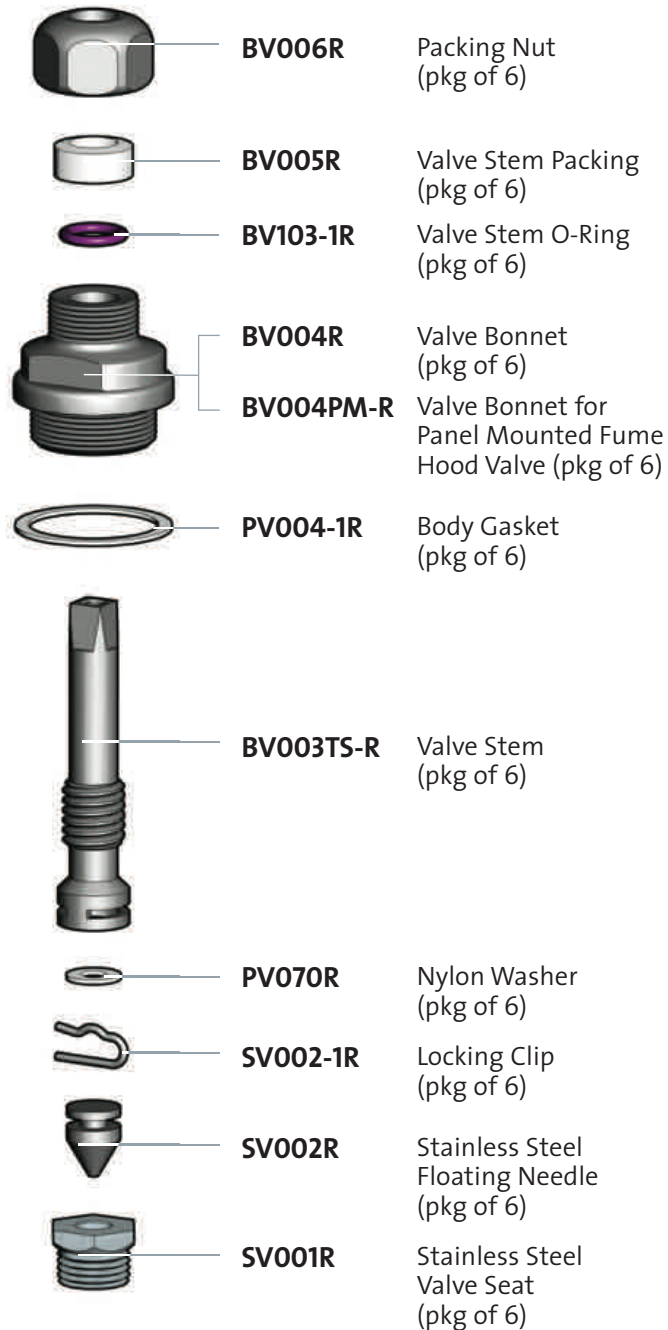

- **BV200FCN** Fine Control Needle Valve Components
- **BV200NFCN-PM** Fine Control Needle Valve Components for Panel Mounted Fume Hood Valve

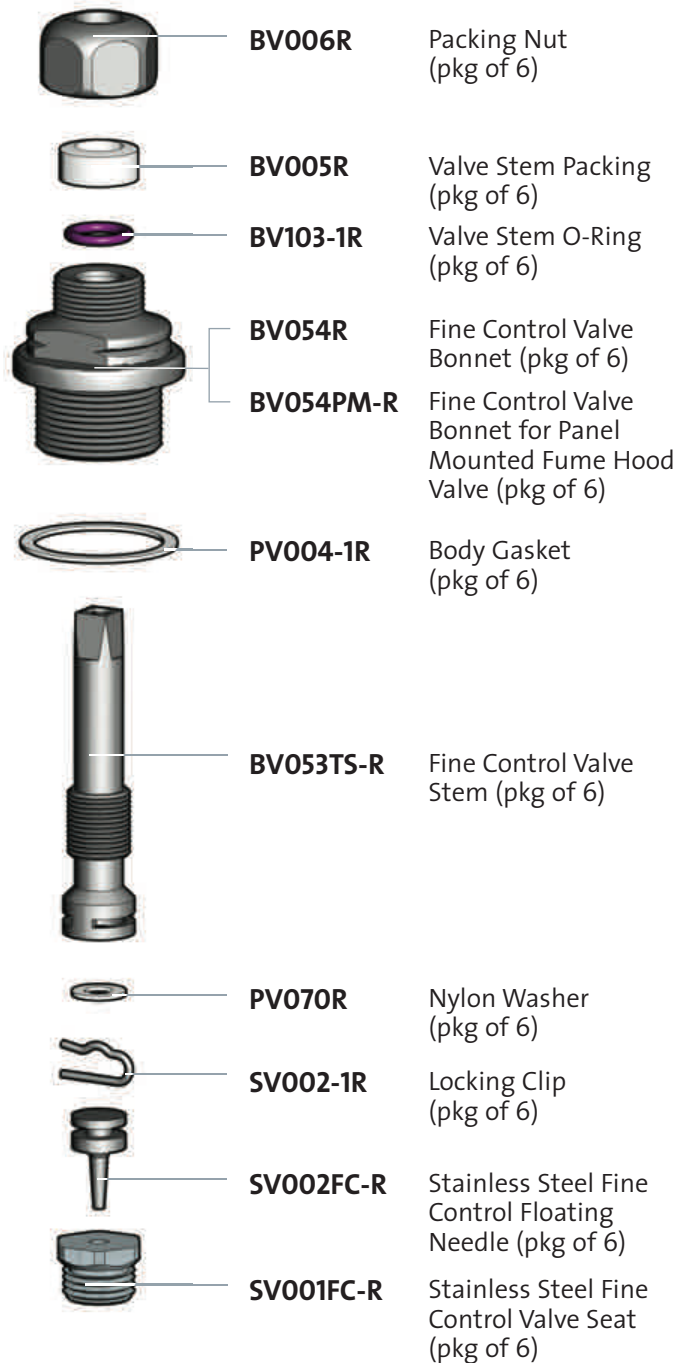

Note: If valve is used for oxygen or pure gas service, components must be specially cleaned, lubricated and packed.

Swing Gooseneck Components



SWING GOOSENECK



B0070R Packing Nut with 1"-22 Male Thread (pkg of 6)



B0071R Friction Ring (pkg of 6)



B0075R Swing Gooseneck Packing (pkg of 6)



B0081R Split Retaining Ring (pkg of 6)



B0226R Swing Gooseneck Adaptor (3/8" Male NPT Inlet, 1"-22 Female Outlet) (pkg of 6)



RIGID GOOSENECK



BO352A-R Retainer Nut (pkg of 6)



PO349R Nylon Washer (pkg of 6)



BO351R Double O-Ring Guide (pkg of 6)



BO353R O-Rings (2 required) (pkg of 12)



PO355R Nylon Spacer (Swing) (pkg of 6)



BO355R Brass Spacer (Rigid) (pkg of 6)



BO356R Rigid/Swing Adaptor (3/8" NPT Male Inlet, 1"-22 Male Outlet) (pkg of 6)

BO356COMP Rigid/Swing Adaptor with Gooseneck Components (PO349 through BO355)



BO350R Rigid/Swing Adaptor (1"-22 Male Thread) (pkg of 6)



BO354R Copper Body Gasket

Notes:

1. To convert a faucet with a rigid gooseneck to swing using swing construction, order BO226 adaptor and SG series swing gooseneck.
2. To convert a faucet with a rigid gooseneck to swing using rigid/swing construction, order BO356COMP (BO356 and parts PO349 through BO355).

○ **L100 / 101 / 102 / 112** Atmospheric Vacuum Breakers

WaterSaver atmospheric vacuum breakers were redesigned in 2004. Vacuum breakers manufactured prior to 2004 utilize a float cup with a cone-shaped bottom. Vacuum breakers manufactured after 2004 utilize a float cup with a cylinder-shaped flat bottom (shown below). The new float cup incorporates a small sealed air pocket that gives the float cup increased buoyancy and reduces spillage at low flow.

Internal components for the new style construction can be used in faucets manufactured prior to 2004. However, in such older faucets, the new components might reduce the water flow through the vacuum breaker. If this occurs, it might be necessary to install the old style components in the vacuum breaker (order "RK100R-OS"). Please consult with the WaterSaver factory for further assistance.

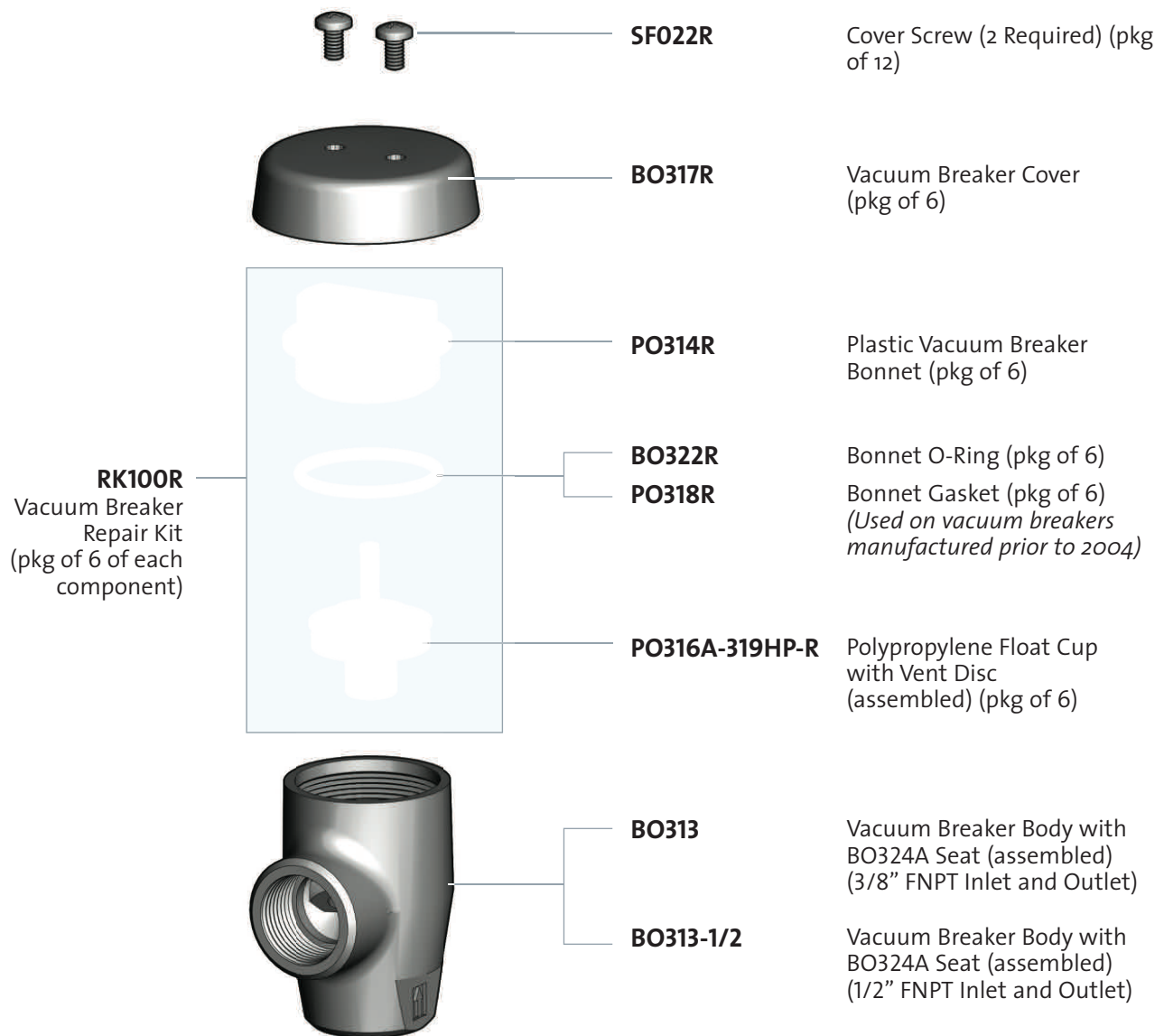

- **BV200S** Steam Valve Components
- **BV200S-PM** Steam Valve Components for Panel Mounted Fume Hood Valve

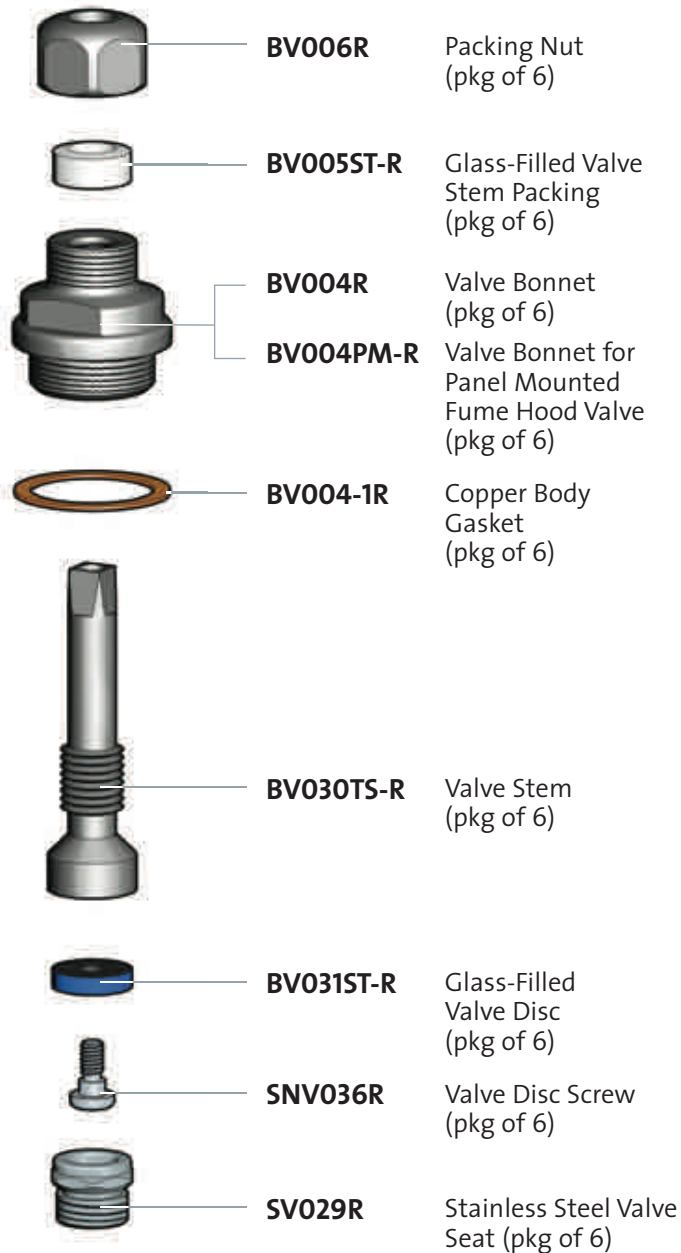

- **BV200W** Water Valve Components
- **BV200W-PM** Water Valve Components for Panel Mounted Fume Hood Valve

Note: BV200W is used on remote control water valves for fume hood use.

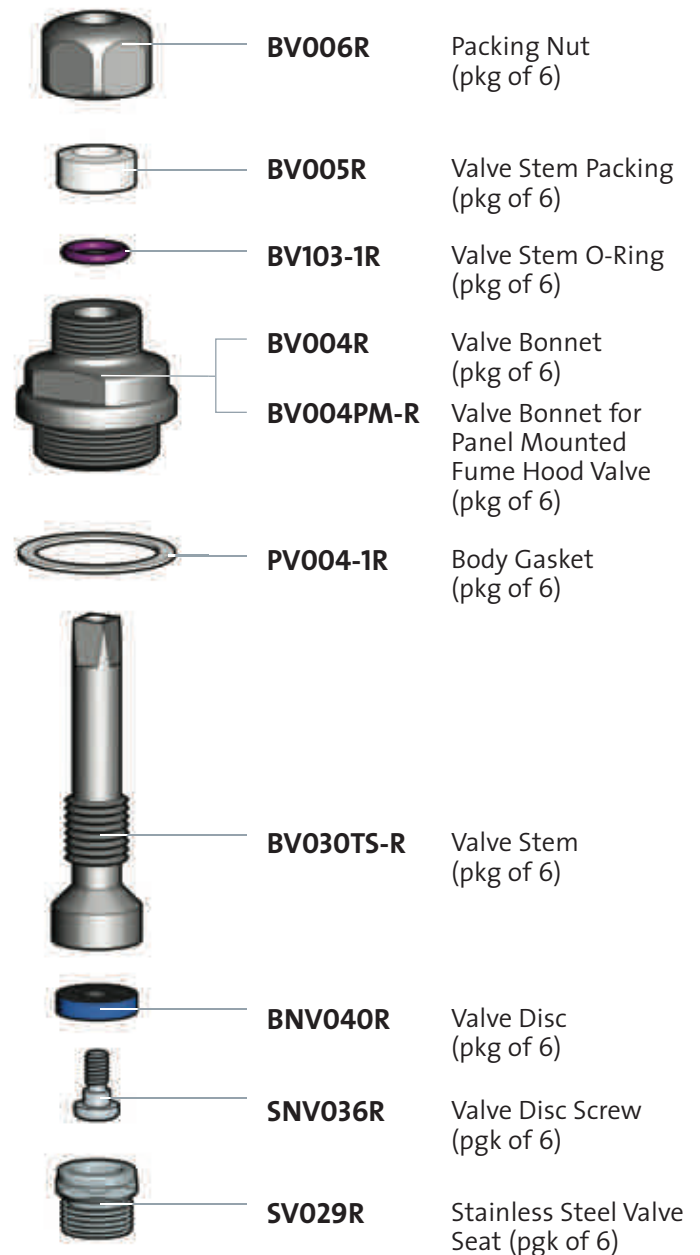

○ L100/101/102/112 Atmospheric Vacuum Breakers

Maximum Pressure: 125 PSI

Maximum Temperature: 180°F

ASSE Certified under ASSE Standard 1001

Atmospheric vacuum breakers are used to prevent back-siphonage of contaminated water into a potable water system. They are not designed to protect against backpressure conditions; protection against backpressure may require installation of a backflow preventer in the water supply line.

WaterSaver vacuum breakers are intended for use on laboratory faucets and valves. They are typically installed as an integral part of a laboratory faucet gooseneck. In addition, they are used in water supply systems installed in fume hoods, mounted between a remote control water valve and an outlet fitting. As such, WaterSaver vacuum breakers are designed and constructed specifically for the requirements of laboratory applications. They are designed to seal properly and prevent spillage at as low a flow as possible, thus facilitating many common laboratory procedures. However, under certain circumstances, spillage of water from under the vacuum breaker cover can occur.

The purpose of these guidelines is to assist in the correct installation, operation and maintenance of WaterSaver vacuum breakers. In addition, these guidelines will assist in troubleshooting in the event that spillage does occur.

IMPORTANT: Be sure to review applicable local plumbing codes prior to selecting or installing a vacuum breaker. Many codes have specific provisions regarding the type of vacuum breaker that may be used and the design of the system in which it is used.

Installation

The water supply line must be thoroughly flushed prior to installation. The presence of any scale, debris, chips, thread sealant, etc. in the water line may cause fouling of the vacuum breaker, prevent proper sealing of the float cup and damage internal components.

The vacuum breaker must be installed with the supply connected to the bottom inlet of the vacuum breaker.

An atmospheric vacuum breaker must be installed downstream of the last valve in the water supply line.

The Uniform Plumbing Code requires that “potable water outlets with hose attachments...shall be protected by... an atmospheric vacuum breaker installed at least six (6) inches above the highest point of usage and located on the discharge side of the last valve.” [Uniform Plumbing Code, Section 603.4.7 (2003)] Consequently, when the vacuum breaker is installed, the bottom of the vacuum breaker body must be at least 6” above the flood level rim of the sink or fixture into which water is discharged. [See Figure 1.] Where a hose is to be attached to a serrated hose end, the vacuum breaker must be installed at least 6” above the highest point to which the hose can be raised. [See Figure 1.]

Vacuum breakers must be installed in a plumb and level position, perpendicular to the finished floor. If a vacuum breaker is installed in a tilted or angled position, the float cup will tend not to seal squarely against the bottom of the vacuum breaker bonnet. This can promote leakage under low flow conditions.

Since atmospheric vacuum breakers require routine inspection and maintenance (primarily cleaning and/or replacement of internal components), they should be installed in locations in which they are readily accessible. In addition, the Uniform Plumbing Code prohibits installing a backflow preventer in any area containing toxic, poisonous or corrosive fumes. [Uniform Plumbing Code, Section 603.4.15 (2003)] Vacuum

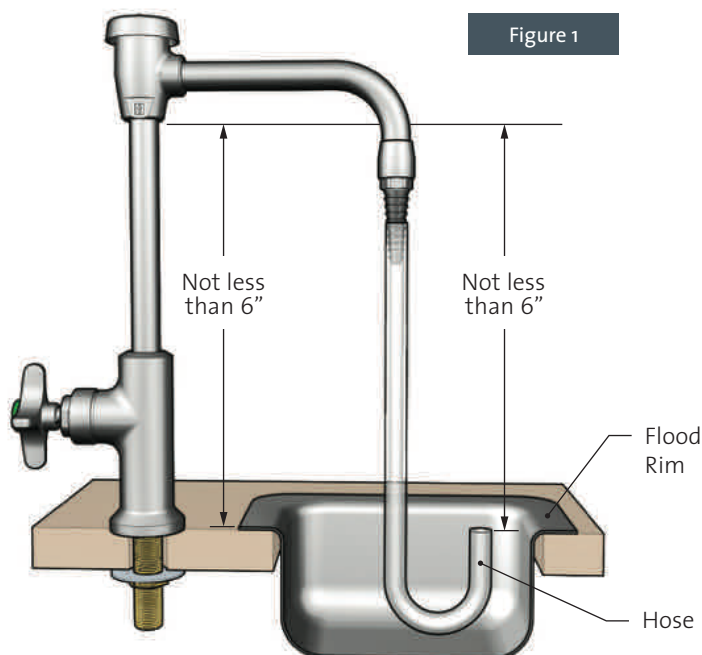

breakers should thus not be installed within the work space of a laboratory fume hood.

Operation

When the water control valve is closed, the vacuum breaker float cup rests on the vacuum breaker seat. [See Figure 2.] In this position, the atmospheric vent is open and the waterway through the seat is closed.

When the water valve is opened, the water flow pushes the float cup up off the seat and against the vacuum breaker bonnet. The float cup gasket seals against the bottom face of the bonnet. This seal prevents water from passing through the atmospheric vent and spilling out from underneath the vacuum breaker cover.

In the event of a loss of pressure on the upstream side of the vacuum breaker and the resulting creation of a negative pressure in the supply line, the float cup drops back down onto the seat. This opens the atmospheric vent and closes the waterway. This action admits air into the discharge line downstream of the vacuum breaker, thereby preventing the creation of a vacuum and stopping any back-siphonage.

An atmospheric vacuum breaker cannot be used in applications where it is subject to continuous water pressure. In addition, the water control valve should not be left open for extended periods of time.

Maintenance

Contamination of the internal components of the vacuum breaker (e.g. mineral deposits on the float cup gasket or bonnet) may cause a loss of the seal between the float cup gasket and bonnet. Therefore, vacuum breakers should be inspected periodically (at least monthly) for contamination and/or deterioration of the internal working components. Components should be cleaned or replaced as required.

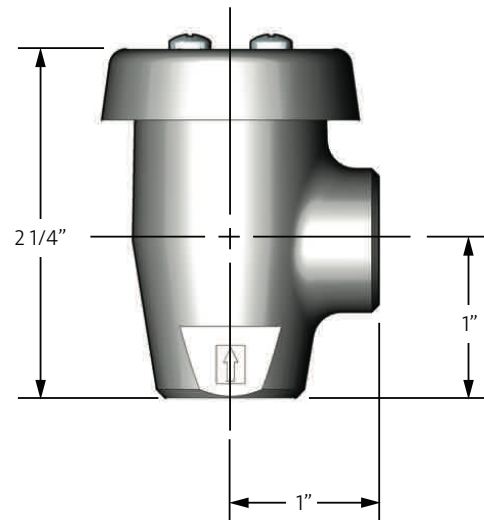
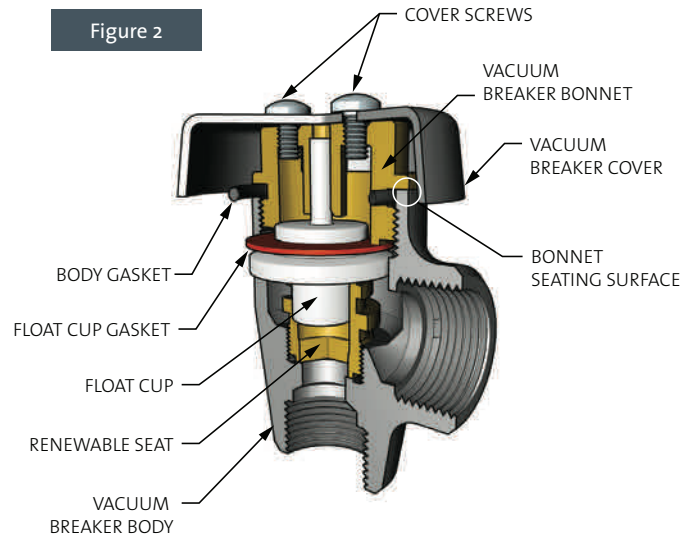

Troubleshooting

The most common problem associated with atmospheric vacuum breakers is the occurrence of spillage of water from underneath the vacuum breaker cover. There are many possible causes of this. Set forth below is a list of the potential causes of spillage, together with the appropriate solution for the problem:

1. **Vacuum Breaker Installed At Angle.** As noted above, if a vacuum breaker is installed in a tilted or angled position, the float cup will not seal evenly against the bottom of the bonnet. To address this issue, adjust the position of the vacuum breaker so as to be plumb and level.
2. **Contamination of Float Cup Gasket.** If the water contains a high level of calcium or other minerals, deposits and scale can accumulate on the float cup gasket. If this occurs, the gasket will not seal completely against the bonnet. The gasket should be cleaned or replaced.
3. **Contamination of Bonnet.** Build-up of deposits can occur on the seating surface of the bonnet as well. The bonnet must then be cleaned or replaced.
4. **High Water Pressure.** As noted above, WaterSaver vacuum breakers are designed specifically for laboratory applications. The float cup and gasket are extremely light to permit sealing at as low a flow as possible (since many laboratory procedures require low flow over an extended period of time). When used in water systems with high water pressure (greater than 70 PSI), these components can wear out more quickly than at low pressure. If that occurs, the vacuum breaker may not seal properly at low flow. In higher pressure applications, the float cup and gasket might require replacement at more frequent intervals.
5. **Deterioration of Bonnet Gasket.** The vacuum breaker bonnet is sealed into the vacuum breaker body using a nylon gasket or O-ring. Over time, this gasket or O-ring can deteriorate and leakage can occur. In that event, the gasket or O-ring should be replaced.
6. **Connection to Elevated Equipment.** As noted above, the

vacuum breaker must be installed at least 6" above the flood level rim of the sink or the highest point which can be reached by a hose attached to the outlet. Thus, if a hose is attached to the serrated end of a laboratory faucet, the free end of the hose should not be capable of reaching a height that is less than 6" below the vacuum breaker.

Spillage can occur in the event that a hose is attached to a faucet and extended above the level of the vacuum breaker. In this situation, when the valve is opened and water is flowing through the system, there can be an accumulation of water in the hose downstream of the vacuum breaker. The pressure created by the weight of the downstream water may exceed the water pressure upstream of the vacuum breaker, causing a negative pressure situation. This will cause a reversal of flow, the vacuum breaker will close, and spillage will occur. In this situation, the vacuum breaker is acting exactly as it is designed in preventing backflow.

The situation described above is most likely to occur when the water control valve is opened a slight amount and left in this position for a long period of time. Fluctuations in supply line pressure and flow may cause the float cup to "flutter" rather than seal continuously against the bonnet. This will accentuate the tendency for a negative pressure situation to develop.

One possible solution for spillage of this type is to install a non-positive closing volume control device (such as the WaterSaver BO358) on the faucet outlet. The control valve can then be fully opened, permitting the vacuum breaker float cup to seal. Water flow is metered using the volume control on the outlet. As noted above, the Uniform Plumbing Code requires that vacuum breakers be located on the discharge side of the last valve in the water line. Therefore, the volume control device must not be capable of fully closing.



Material Handling USA
800-326-4403
<https://www.mh-usa.com/>



Material Handling USA

**Call Now for a Free
Quote or Site Visit!**

222 S. Main St. 5th Floor
Salt Lake City, UT 84101
800-326-4403
<https://www.mh-usa.com/>

SUPERSTORE

MH-USA

Material Handling USA